

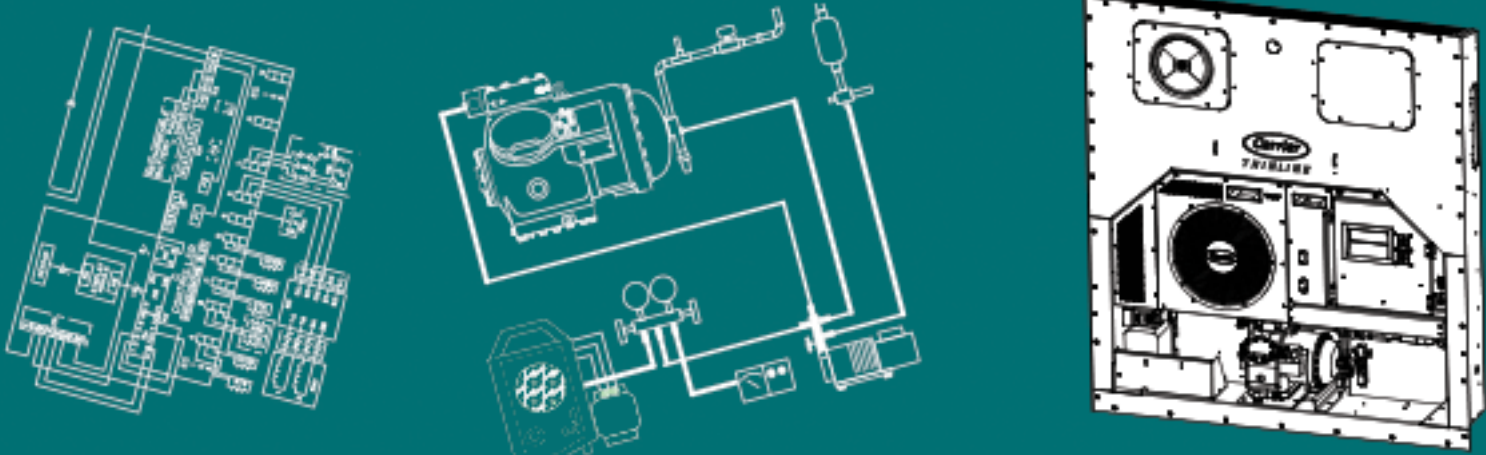

Container Refrigeration



OPERATIONS AND SERVICE MANUAL

For

69NT40-541-500 to 599

Container Refrigeration Units



OPERATIONS AND SERVICE MANUAL

For

69NT40-541-500 to 599

TABLE OF CONTENTS

| Paragraph Number | Page |
|---------------------------------------|------------|
| SAFETY SUMMARY | 1-1 |
| 1.1 GENERAL SAFETY NOTICES | 1-1 |
| 1.2 FIRST AID | 1-1 |
| 1.3 OPERATING PRECAUTIONS | 1-1 |
| 1.4 MAINTENANCE PRECAUTIONS | 1-1 |
| 1.5 SPECIFIC HAZARD STATEMENTS | 1-1 |
| INTRODUCTION | 2-1 |
| 2.1 INTRODUCTION | 2-1 |
| 2.2 CONFIGURATION IDENTIFICATION | 2-1 |
| 2.3 FEATURE DESCRIPTIONS | 2-1 |
| 2.3.1 Control Box | 2-1 |
| 2.3.2 Controller | 2-1 |
| 2.3.3 Temperature Readout | 2-1 |
| 2.3.4 Pressure Readout | 2-1 |
| 2.3.5 Compressor | 2-1 |
| 2.3.6 Condenser Coil | 2-1 |
| 2.3.7 Condenser Grille | 2-1 |
| 2.3.8 Evaporator | 2-1 |
| 2.3.9 Evaporator Fan Operation | 2-1 |
| 2.3.10 Plate Set | 2-1 |
| 2.4 OPTION DESCRIPTIONS | 2-1 |
| 2.4.1 Battery | 2-1 |
| 2.4.2 Dehumidification | 2-1 |
| 2.4.3 USDA | 2-1 |
| 2.4.4 Interrogator | 2-2 |
| 2.4.5 Remote Monitoring | 2-2 |
| 2.4.6 Quest - CCPC | 2-2 |
| 2.4.7 Communications Interface Module | 2-2 |
| 2.4.8 460 Volt Cable | 2-2 |
| 2.4.9 Autotransformer | 2-2 |
| 2.4.10 230 Volt Cable | 2-2 |
| 2.4.11 Gutters | 2-2 |
| 2.4.12 Handles | 2-2 |
| 2.4.13 Thermometer Port | 2-2 |
| 2.4.14 Back Panels | 2-2 |
| 2.4.15 Cable Restraint | 2-2 |
| 2.4.16 Upper Air (Fresh Air Make Up) | 2-2 |
| 2.4.17 Lower Air (Fresh Air Make Up) | 2-2 |
| 2.4.18 Labels | 2-2 |
| 2.4.19 Display Module | 2-2 |
| 2.4.20 Emergency Bypass | 2-2 |
| 2.4.21 eAutoFresh | 2-2 |
| 2.4.22 Controlled Atmosphere | 2-2 |

| | |
|--|------------|
| DESCRIPTION | 3-1 |
| 3.1 GENERAL DESCRIPTION | 3-1 |
| 3.1.1 Refrigeration Unit – Front Section | 3-1 |
| 3.1.2 Fresh Air Makeup Vent | 3-1 |
| 3.1.3 Evaporator Section | 3-2 |
| 3.1.4 Compressor Section | 3-3 |
| 3.1.5 Air-Cooled Condenser Section | 3-4 |
| 3.1.6 Control Box Section | 3-5 |
| 3.1.7 Communications Interface Module (option) | 3-5 |
| 3.2 REFRIGERATION SYSTEM DATA | 3-6 |
| 3.3 ELECTRICAL DATA | 3-7 |
| 3.4 SAFETY AND PROTECTIVE DEVICES | 3-8 |
| 3.5 REFRIGERATION CIRCUIT | 3-9 |
| MICROPROCESSOR | 4-1 |
| 4.1 TEMPERATURE CONTROL MICROPROCESSOR SYSTEM | 4-1 |
| 4.1.1 Keypad | 4-2 |
| 4.1.2 Display Module | 4-2 |
| 4.1.3 Controller | 4-3 |
| 4.2 CONTROLLER SOFTWARE | 4-3 |
| 4.2.1 Configuration Software (CnF Variables) | 4-3 |
| 4.2.2 Operational Software (Cd Function Codes) | 4-4 |
| 4.3 MODES OF OPERATION | 4-4 |
| 4.3.1 Perishable Mode Temperature Control | 4-4 |
| 4.3.2 Perishable Pulldown | 4-4 |
| 4.3.3 Perishable Steady State | 4-4 |
| 4.3.4 Perishable Idle, Air Circulation | 4-4 |
| 4.3.5 Perishable Heating | 4-4 |
| 4.3.6 Perishable Mode Dehumidification | 4-5 |
| 4.3.7 Perishable, Dehumidification – Bulb Mode | 4-6 |
| 4.3.8 Perishable Economy | 4-6 |
| 4.3.9 Perishable Mode Cooling – Sequence of Operation | 4-6 |
| 4.3.10 Perishable Mode Heating – Sequence of Operation | 4-7 |
| 4.3.11 Frozen Mode - Temperature Control | 4-7 |
| 4.3.12 Frozen Steady State | 4-7 |
| 4.3.13 Frozen Idle Mode | 4-8 |
| 4.3.14 Frozen “Heat” Mode | 4-8 |
| 4.3.15 Frozen Economy Mode | 4-8 |
| 4.3.16 Frozen Mode Cooling – Sequence of Operation | 4-9 |
| 4.3.17 Defrost | 4-9 |
| 4.3.18 Defrost Operation | 4-9 |
| 4.3.19 Defrost Related Settings | 4-11 |
| 4.4 PROTECTION MODES OF OPERATION | 4-11 |
| 4.4.1 Evaporator Fan Operation | 4-11 |
| 4.4.2 Failure Action | 4-11 |
| 4.4.3 Generator Protection | 4-11 |
| 4.4.4 Condenser Pressure Control | 4-11 |
| 4.5 QUEST – CCPC | 4-11 |
| 4.6 CONTROLLER ALARMS | 4-12 |

| | | |
|------------------------|--|------------|
| 4.7 | PRE-TRIP DIAGNOSTICS | 4-12 |
| 4.8 | DATAORDER | 4-13 |
| 4.8.1 | DataCORDER Software | 4-13 |
| 4.8.2 | Sensor Configuration (dCF02) | 4-14 |
| 4.8.3 | Logging Interval (dCF03) | 4-14 |
| 4.8.4 | Thermistor Format (dCF04) | 4-14 |
| 4.8.5 | Sampling Type (dCF05 & dCF06) | 4-16 |
| 4.8.6 | Alarm Configuration (dCF07 – dCF10) | 4-16 |
| 4.8.7 | DataCORDER Power-Up | 4-16 |
| 4.8.8 | Pre-trip Data Recording | 4-16 |
| 4.8.9 | DataCORDER Communications | 4-16 |
| 4.8.10 | USDA Cold Treatment | 4-17 |
| 4.8.11 | USDA Cold Treatment Procedure | 4-17 |
| 4.8.12 | DataCORDER Alarms | 4-18 |
| 4.8.13 | ISO Trip Header | 4-18 |
| 4.9 | CONTROLLER CONFIGURATION VARIABLES | 4-19 |
| 4.10 | CONTROLLER FUNCTION CODES | 4-21 |
| 4.11 | CONTROLLER ALARM INDICATIONS | 4-31 |
| 4.12 | CONTROLLER PRE-TRIP TEST CODES | 4-42 |
| OPERATION | | 5-1 |
| 5.1 | INSPECTION (BEFORE LOADING) | 5-1 |
| 5.2 | CONNECT POWER | 5-1 |
| 5.2.1 | Connection To 380/460 VAC Power | 5-1 |
| 5.2.2 | Connection to 190/230VAC Power (option) | 5-1 |
| 5.3 | ADJUST FRESH AIR MAKEUP VENT | 5-1 |
| 5.3.1 | Upper Fresh Air Makeup Vent | 5-2 |
| 5.3.2 | Vent Position Sensor | 5-2 |
| 5.4 | EAUTOFRESH OPERATION | 5-2 |
| 5.4.1 | eAutoFresh Pre-Trip Inspection | 5-3 |
| 5.4.2 | eAutoFresh Start-Up Procedure | 5-3 |
| 5.4.3 | eAutoFresh Modes of Operation | 5-3 |
| 5.5 | CONNECT REMOTE MONITORING RECEPTACLE | 5-4 |
| 5.6 | STARTING AND STOPPING INSTRUCTIONS | 5-4 |
| 5.6.1 | Starting the Unit | 5-4 |
| 5.6.2 | Stopping the Unit | 5-4 |
| 5.7 | START-UP INSPECTION | 5-4 |
| 5.7.1 | Physical Inspection | 5-4 |
| 5.7.2 | Check Controller Function Codes | 5-4 |
| 5.7.3 | Start Temperature Recorder | 5-4 |
| 5.7.4 | Complete Inspection | 5-4 |
| 5.8 | PRE-TRIP DIAGNOSTICS | 5-5 |
| 5.9 | PROBE DIAGNOSTICS | 5-6 |
| 5.10 | EMERGENCY BYPASS OPERATION (OPTION) | 5-7 |
| TROUBLESHOOTING | | 6-1 |
| 6.1 | UNIT WILL NOT START OR STARTS THEN STOPS | 6-1 |
| 6.2 | UNIT OPERATES LONG OR CONTINUOUSLY LONG IN COOLING | 6-1 |
| 6.3 | UNIT RUNS BUT HAS INSUFFICIENT COOLING | 6-2 |
| 6.4 | UNIT WILL NOT HEAT OR HAS INSUFFICIENT HEATING | 6-2 |

| | | |
|----------------|---|------------|
| 6.5 | UNIT WILL NOT TERMINATE HEATING | 6-2 |
| 6.6 | UNIT WILL NOT DEFROST PROPERLY | 6-3 |
| 6.7 | ABNORMAL PRESSURES (COOLING) | 6-3 |
| 6.8 | ABNORMAL NOISE OR VIBRATIONS | 6-4 |
| 6.9 | MICROPROCESSOR MALFUNCTION | 6-4 |
| 6.10 | NO EVAPORATOR AIR FLOW OR RESTRICTED AIR FLOW | 6-4 |
| 6.11 | EAUTOFRESH NOT OPERATING | 6-5 |
| 6.12 | THERMOSTATIC EXPANSION VALVE MALFUNCTION | 6-5 |
| 6.13 | AUTOTRANSFORMER MALFUNCTION | 6-5 |
| SERVICE | | 7-1 |
| 7.1 | SECTION LAYOUT | 7-1 |
| 7.2 | MANIFOLD GAUGE SET | 7-1 |
| 7.3 | SERVICE VALVES | 7-2 |
| 7.4 | PUMP THE UNIT DOWN | 7-3 |
| 7.5 | REFRIGERANT LEAK CHECKING | 7-3 |
| 7.6 | EVACUATION AND DEHYDRATION | 7-3 |
| 7.6.1 | General | 7-3 |
| 7.6.2 | Preparation | 7-3 |
| 7.6.3 | Complete System | 7-4 |
| 7.6.4 | Procedure - Partial System | 7-4 |
| 7.7 | REFRIGERANT CHARGE | 7-4 |
| 7.7.1 | Checking the Refrigerant Charge | 7-5 |
| 7.7.2 | Adding Refrigerant to System (Full Charge) | 7-5 |
| 7.7.3 | Adding Refrigerant to System (Partial Charge) | 7-5 |
| 7.8 | COMPRESSOR | 7-5 |
| 7.8.1 | Removal and Replacement of Compressor | 7-5 |
| 7.8.2 | Compressor Disassembly | 7-6 |
| 7.8.3 | Compressor Reassembly | 7-8 |
| 7.8.4 | Preparation | 7-9 |
| 7.8.5 | Installing the Components | 7-9 |
| 7.8.6 | Compressor Oil Level | 7-9 |
| 7.9 | HIGH PRESSURE SWITCH | 7-10 |
| 7.9.1 | Checking High Pressure Switch | 7-10 |
| 7.9.2 | Replacing the High Pressure Switch | 7-11 |
| 7.10 | CONDENSER COIL | 7-11 |
| 7.10.1 | Condenser Coil Cleaning | 7-11 |
| 7.10.2 | Condenser Coil Removal | 7-11 |
| 7.10.3 | Condenser Coil Preparation | 7-12 |
| 7.10.4 | Condenser Coil Installation | 7-12 |
| 7.11 | CONDENSER FAN AND FAN MOTOR | 7-13 |
| 7.11.1 | Condenser Fan Motor Remove/Replace | 7-13 |
| 7.12 | FILTER-DRIER | 7-13 |
| 7.13 | EVAPORATOR COIL & HEATER ASSEMBLY | 7-13 |
| 7.13.1 | Evaporator Coil Replacement | 7-14 |
| 7.13.2 | Evaporator Heater Replacement | 7-14 |

| | | |
|--------|---|------------|
| 7.14 | EVAPORATOR FAN AND MOTOR ASSEMBLY | 7-15 |
| 7.14.1 | Replacing the Evaporator Fan Assembly | 7-15 |
| 7.14.2 | Disassemble the Evaporator Fan Assembly | 7-15 |
| 7.14.3 | Assemble the Evaporator Fan Assembly | 7-15 |
| 7.15 | EVAPORATOR SECTION CLEANING | 7-15 |
| 7.16 | THERMOSTATIC EXPANSION VALVE | 7-16 |
| 7.16.1 | Checking Superheat | 7-16 |
| 7.16.2 | TXV Replacement | 7-17 |
| 7.17 | SUCTION MODULATION VALVE | 7-18 |
| 7.17.1 | Pre-check Procedure | 7-18 |
| 7.18 | VALVE OVERRIDE CONTROLS | 7-19 |
| 7.18.1 | Checking the Stepper Valve | 7-19 |
| 7.18.2 | Checking the Controller | 7-20 |
| 7.18.3 | SMV Emergency Repair Procedure | 7-20 |
| 7.19 | AUTOTRANSFORMER | 7-20 |
| 7.20 | CONTROLLER | 7-20 |
| 7.20.1 | Handling Controller | 7-20 |
| 7.20.2 | Controller Troubleshooting | 7-21 |
| 7.20.3 | Controller Programming Procedure | 7-21 |
| 7.20.4 | Removing and Installing the Controller | 7-22 |
| 7.20.5 | Battery Replacement | 7-23 |
| 7.21 | TEMPERATURE SENSOR SERVICE | 7-23 |
| 7.21.1 | Sensor Checkout Procedure | 7-23 |
| 7.21.2 | Sensor Replacement | 7-24 |
| 7.21.3 | Sensor Re-Installation | 7-25 |
| 7.22 | VENT POSITION SENSOR (VPS) | 7-25 |
| 7.23 | EAUTOFRESH SERVICE | 7-26 |
| 7.23.1 | Servicing the eAutoFresh Air Filter | 7-26 |
| 7.23.2 | Checking eAutoFresh Drive System | 7-26 |
| 7.23.3 | Servicing the eAutoFresh Drive System | 7-27 |
| 7.24 | MAINTENANCE OF PAINTED SURFACES | 7-29 |
| 7.25 | COMMUNICATIONS INTERFACE MODULE INSTALLATION | 7-29 |
| | ELECTRICAL WIRING SCHEMATIC AND DIAGRAMS | 8-1 |
| 8.1 | INTRODUCTION | 8-1 |
| | INDEX | 1-1 |

LIST OF ILLUSTRATIONS

| FIGURE NUMBER | Page |
|---|------|
| Figure 3.1 Refrigeration Unit - Front Section | 3-1 |
| Figure 3.2 Evaporator Section - Units with Center Access Panel | 3-2 |
| Figure 3.3 Compressor Section | 3-3 |
| Figure 3.4 Condenser Section | 3-4 |
| Figure 3.5 Control Box Section | 3-5 |
| Figure 3.6 Refrigeration Circuit Schematic | 3-10 |
| Figure 4.1 Temperature Control System | 4-1 |
| Figure 4.2 Keypad | 4-2 |
| Figure 4.3 Display Module | 4-3 |
| Figure 4.4 Control Module | 4-3 |
| Figure 4.5 Controller Operation - Perishable Mode | 4-5 |
| Figure 4.6 Perishable Mode Cooling | 4-6 |
| Figure 4.7 Perishable Mode Heating | 4-7 |
| Figure 4.8 Controller Operation - Frozen Mode | 4-8 |
| Figure 4.9 Frozen Mode | 4-9 |
| Figure 4.10 | 4-10 |
| Figure 4.11 Standard Configuration Report | 4-15 |
| Figure 4.12 Alarm Troubleshooting Sequence | 4-30 |
| Figure 5.1 Autotransformer | 5-1 |
| Figure 5.2 Make Up Air Flow Chart | 5-2 |
| Figure 7.1 Manifold Gauge Set | 7-1 |
| Figure 7.2 R-134a Manifold Gauge/Hose Set | 7-2 |
| Figure 7.3 Service Valve | 7-2 |
| Figure 7.4 Refrigeration System Service Connections | 7-4 |
| Figure 7.5 Compressor | 7-6 |
| Figure 7.6 Exploded View of Valve Plate | 7-6 |
| Figure 7.7 Bottom Plate Removed | 7-7 |
| Figure 7.8 Oil Pump and Bearing Head | 7-7 |
| Figure 7.9 Low Profile Oil Pump | 7-7 |
| Figure 7.10 Motor End Cover | 7-8 |
| Figure 7.11 Equalizing Tube and Lock Screw Assembly | 7-8 |
| Figure 7.12 Crankshaft Assembly | 7-8 |
| Figure 7.13 Suction Valve and Positioning Rings | 7-9 |
| Figure 7.14 Piston Ring | 7-9 |
| Figure 7.15 High Pressure Switch Testing | 7-10 |
| Figure 7.16 Condenser Fan Position | 7-12 |
| Figure 7.17 Heater Arrangement | 7-14 |
| Figure 7.18 Evaporator Fan Assembly | 7-15 |
| Figure 7.19 Thermostatic Expansion Valve Bulb | 7-16 |
| Figure 7.20 Thermostatic Expansion Valve | 7-17 |
| Figure 7.21 Hermetic Thermostatic Expansion Valve Bulb Location | 7-17 |
| Figure 7.22 Hermetic Thermostatic Expansion Valve Brazing Procedure | 7-17 |

Figure 7.23 Suction Modulation Valve (SMV) 7-18

Figure 7.24 Controller Section of the Control Box 7-21

Figure 7.25 Sensor Types 7-24

Figure 7.26 Sensor and Cable Splice 7-24

Figure 7.27 Supply Sensor Positioning 7-25

Figure 7.28 Return Sensor Positioning 7-25

Figure 7.29 Stepper Components 7-26

Figure 7.30 Jumper Assembly 7-27

Figure 7.31 Motor Cup Replacement 7-28

Figure 7.32 Communications Interface Installation 7-29

Figure 7.33 R-134a Compressor Pressure and Motor Current Curves Vs. Ambient Temperature, Sheet 1 . 7-33

Figure 7.34 R-134a Compressor Pressure and Motor Current Curves Vs. Ambient Temperature, Sheet 2 . 7-34

Figure 8.1 LEGEND 8-1

Figure 8.2 Schematic Diagram 8-2

Figure 8.3 Unit Wiring Diagram (Sheet 1 of 2) 8-3

Figure 8.4 Unit Wiring Diagram (Sheet 2 of 2) 8-4

LIST OF TABLES

| TABLE NUMBER | Page |
|--|-------------|
| Table 3–1 Safety and Protective Devices | 3–8 |
| Table 4–1 Keypad Function | 4–2 |
| Table 4–2 Data CORDER Configuration Variables | 4–14 |
| Table 4–3 Data CORDER Standard Configurations | 4–16 |
| Table 4–4 Controller Configuration Variables | 4–19 |
| Table 4–5 Controller Function Codes | 4–21 |
| Table 4–6 Controller Alarm Indications | 4–41 |
| Table 4–7 Controller Pre-Trip Test Codes | 4–42 |
| Table 4–8 DataCORDER Function Code Assignments | 4–48 |
| Table 4–9 DataCORDER Pre-Trip Result Records | 4–49 |
| Table 4–10 DataCORDER Alarm Indications | 4–50 |
| Table 7–1 Valve Override Control Displays | 7–19 |
| Table 7–2 Sensor Temperature/Resistance Chart | 7–23 |
| Table 7–3 Recommended Bolt Torque Values | 7–30 |
| Table 7–4 Wear Limits For Compressors | 7–30 |
| Table 7–5 Compressor Torque Values | 7–31 |
| Table 7–6 R-134a Temperature - Pressure Chart | 7–32 |

SECTION 1

SAFETY SUMMARY

1.1 GENERAL SAFETY NOTICES

Installation and servicing of refrigeration equipment can be hazardous due to system pressures and electrical components. Only trained and qualified service personnel should install, repair, or service refrigeration equipment.

The following general safety notices supplement specific warnings and cautions appearing elsewhere in this manual. They are recommended precautions that must be understood and applied during operation and maintenance of the equipment covered herein. The general safety notices are presented in the following three sections labeled: First Aid, Operating Precautions and Maintenance Precautions. A listing of the specific warnings and cautions appearing elsewhere in the manual follows the general safety notices.

1.2 FIRST AID

An injury, no matter how slight, should never go unattended. Always obtain first aid or medical attention immediately.

1.3 OPERATING PRECAUTIONS

Always wear safety glasses.

Keep hands, clothing and tools clear of the evaporator and condenser fans.

Wear appropriate personal protective equipment for the work being undertaken.

No work should be performed on the unit until all circuit breakers, start-stop switches are turned off, and power supply is disconnected.

In case of severe vibration or unusual noise, stop the unit and investigate.

1.4 MAINTENANCE PRECAUTIONS

Beware of unannounced starting of the evaporator and condenser fans. Do not open the condenser fan grille or evaporator access panels before turning power off, and disconnecting and securing the power plug.

Be sure power is turned off before working on motors, controllers, solenoid valves, and electrical control switches. Tag circuit breaker and power supply to prevent accidental energizing of circuit.

Do not bypass any electrical safety devices, e.g. bridging an overload, or using any sort of jumper wires. Problems with the system should be diagnosed and any necessary repairs performed by qualified service personnel.

When performing any arc welding on the unit or container, disconnect all wire harness connectors from the modules in both control boxes. Do not remove wire harness from the modules unless you are grounded to the unit frame with a static safe wrist strap.

In case of electrical fire, open circuit switch and extinguish with CO₂ (never use water).

1.5 SPECIFIC HAZARD STATEMENTS

To help identify the label hazards on the unit and explain the level of awareness each one carries, an explanation is given with the appropriate consequences:

DANGER – Indicates an immediate hazard that WILL result in severe personal injury or death.

WARNING – Warns against hazards or unsafe conditions which COULD result in severe personal injury or death.

CAUTION – Warns against potentially hazardous or unsafe practices that could result in minor personal injury, product or property damage.

The statements listed below are applicable to the refrigeration unit and appear elsewhere in this manual. These recommended precautions must be understood and applied during operation and maintenance of the equipment covered herein.

WARNING

EXPLOSION HAZARD: Failure to follow this WARNING can result in death, serious personal injury and / or property damage. Never use air or gas mixtures containing oxygen (O₂) for leak testing or operating the product.

Charge Only With R-134a: Refrigerant must conform to AHRI Standard 700 specification.

WARNING

Beware of unannounced starting of the evaporator and condenser fans. The unit may cycle the fans and compressor unexpectedly as control requirements dictate.

 **WARNING**

Do not attempt to remove power plug(s) before turning OFF start-stop switch (ST), unit circuit breaker(s), and external power source.

 **WARNING**

Make sure the power plugs are clean and dry before connecting to power receptacle.

 **WARNING**

Make sure that the unit circuit breaker(s) (CB-1 & CB-2) and the START-STOP switch (ST) are in the "O" (OFF) position before connecting to any electrical power source.

 **WARNING**

Make sure power to the unit is OFF and power plug disconnected before replacing the compressor.

 **WARNING**

Do not use a nitrogen cylinder without a pressure regulator.

 **WARNING**

Do not remove the condenser fan grille before turning power OFF and disconnecting power plug.

 **WARNING**

Always turn OFF the unit circuit breakers (CB-1 & CB-2) and disconnect main power supply before working on moving parts.

 **WARNING**

The unit power plug must be disconnected to remove power from circuit breaker CB1.

 **WARNING**

Before disassembly of any external compressor component make sure to relieve possible internal pressure by loosening the bolts and tapping the component with a soft hammer to break the seal.

 **CAUTION**

Do not remove wire harnesses from controller unless you are grounded to the unit frame with a static safe wrist strap.

 **CAUTION**

Unplug all controller wire harness connectors before performing arc welding on any part of the container.

 **CAUTION**

Pre-trip inspection should not be performed with critical temperature cargoes in the container.

 **CAUTION**

When Pre-Trip key is pressed, dehumidification and bulb mode will be deactivated. At the completion of Pre-Trip activity, dehumidification and bulb mode must be reactivated.

 **CAUTION**

When a failure occurs during automatic testing, the unit will suspend operation awaiting operator intervention.

 **CAUTION**

When Pre-Trip test Auto 2 runs to completion without being interrupted, the unit will terminate pre-trip and display "Auto 2" "end." The unit will suspend operation until the user depresses the ENTER key!

⚠ CAUTION

The unit will remain in the full cooling mode as long as the emergency bypass switch is in the BYPASS position and the MODE SWITCH is in the FULL COOL position. If the cargo may be damaged by low temperatures, the operator must monitor container temperature and manually cycle operation as required to maintain temperature within required limits.

⚠ CAUTION

To prevent trapping liquid refrigerant in the manifold gauge set, be sure set is brought to suction pressure before disconnecting.

⚠ CAUTION

Removing the compressor motor press-fit stator in the field is not recommended. The rotor and stator are a matched pair and should not be separated.

⚠ CAUTION

The copper tube that connects to the oil suction strainer extends out the bottom with the bottom plate removed. Take precautions to avoid bending or breaking it while changing crankcase positions.

⚠ CAUTION

Ensure that the thrust washer does not fall off dowel pins while installing oil pump.

⚠ CAUTION

The set screw on the crankshaft must be removed for this type of oil pump. (See Figure 6-8.)

⚠ CAUTION

Use only Carrier Transicold approved Polyol Ester Oil (POE) – Castrol-Icematic SW20 compressor oil with R-134a. Buy in quantities of one quart or smaller. When using this hygroscopic oil, immediately reseal. Do not leave container of oil open or contamination will occur.

⚠ CAUTION

Take necessary steps (place plywood over coil or use sling on motor) to prevent motor from falling into condenser coil.

⚠ CAUTION

DO NOT disassemble piston from NEW suction modulating valve powerhead assembly. Doing so may result in damage to piston.

⚠ CAUTION

Unplug all controller connectors before performing arc welding on any part of the container.

⚠ CAUTION

The unit must be OFF whenever a programming card is inserted or removed from the controller programming port.

⚠ CAUTION

Do not allow moisture to enter wire splice area as this may affect sensor resistance.

SECTION 2

INTRODUCTION

2.1 INTRODUCTION

The Carrier Transicold model 69NT40-541-500 to 599 series units are of lightweight aluminum frame construction designed to fit in the front of a container and serve as the container's front wall.

They are one piece, self-contained, all-electric units, which include cooling and heating systems to provide precise temperature control.

The units are supplied with a complete charge of refrigerant R-134a and compressor lubricating oil, and are ready for operation upon installation. Forklift pockets are provided for unit installation and removal.

The base unit operates on nominal 380/460 volt, 3-phase, 50/60 hertz power. An optional autotransformer may be fitted to allow operation on nominal 190/230, 3 phase, 50/60 hertz power. Power for the control system is provided by a transformer, which steps the supply power down to 18 and 24 volts, single phase.

The controller is a Carrier Transicold Micro-Link 3 microprocessor. The controller operates automatically to select cooling, holding or heating as required to maintain the desired set point temperature within very close limits. The unit may also be equipped with an electronic temperature recorder.

The controller has a keypad and display for viewing or changing operating parameters. The display is also equipped with lights to indicate various modes of operation.

2.2 CONFIGURATION IDENTIFICATION

Unit identification information is provided on a plate located near the compressor. The plate provides the unit model number, the unit serial number and the unit parts identification number (PID). The model number identifies the overall unit configuration while the PID provides information on specific optional equipment, factory provisions to allow for field installation of optional equipment and differences in detailed parts.

2.3 FEATURE DESCRIPTIONS

2.3.1 Control Box

Units are equipped with an aluminum control box, and may be fitted with a lockable door.

2.3.2 Controller

The unit is equipped with a Micro-Link 3 microprocessor system.

2.3.3 Temperature Readout

The unit is fitted with suction and discharge refrigerant temperature sensors. The sensor readings may be viewed on the controller display.

2.3.4 Pressure Readout

The is fitted with suction and discharge pressure transducers. The transducer readings may be viewed on the controller display.

2.3.5 Compressor

The unit is fitted with a single speed reciprocating compressor.

2.3.6 Condenser Coil

The unit is fitted with a two-row square formed condenser coil using 7mm tubing.

2.3.7 Condenser Grille

Condenser grilles are direct bolted.

2.3.8 Evaporator

The evaporator section is equipped with a hermetic thermal expansion valve (TXV) and a heat exchanger. The unit has six heaters.

2.3.9 Evaporator Fan Operation

Units are equipped with three-phase evaporator fan motors. Opening of an evaporator fan internal protector will shut down the unit.

2.3.10 Plate Set

Each unit is equipped with a tethered set of wiring schematic and wiring diagram plates. The plate sets are ordered using a seven-digit base part number and a two-digit dash number.

2.4 OPTION DESCRIPTIONS

Various options may be factory or field equipped to the base unit. These options are described in the following sub-paragraphs.

2.4.1 Battery

The refrigeration controller may be fitted with standard replaceable batteries or a rechargeable battery pack. Rechargeable battery packs may be fitted in the standard location or in a secure location.

2.4.2 Dehumidification

The unit may be fitted with a humidity sensor. This sensor allows setting of a humidity set point in the controller. In dehumidification mode the controller will operate to reduce internal container moisture level.

2.4.3 USDA

The unit may be supplied with fittings for additional temperature probes, which allow recording of USDA Cold Treatment data by the integral DataCORDER function of the Micro-Link refrigeration controller.

2.4.4 Interrogator

Units that use the DataCORDER function are fitted with interrogator receptacles for connection of equipment to download the recorded data. Two receptacles may be fitted; one is accessible from the front of the container and the other mounted inside the container (with the USDA receptacles).

2.4.5 Remote Monitoring

The unit may be fitted with a remote monitoring receptacle. This item allows connection of remote indicators for COOL, DEFROST and IN RANGE. Unless otherwise indicated, the receptacle is mounted at the control box location.

2.4.6 Quest – CCPC

Compressor–Cycle Perishable Cooling (CCPC) is a method of temperature control used during steady–state perishable cooling that cycles the compressor on and off according to supply / return air temperature conditions.

2.4.7 Communications Interface Module

The unit may be fitted with a communications interface module. The communications interface module is a slave module which allows communication with a master central monitoring station. The module will respond to communication and return information over the main power line. Refer to the ship master system technical manual for further information.

2.4.8 460 Volt Cable

Various power cable and plug designs are available for the main 460 volt supply. The plug options tailor the cables to each customer's requirements.

2.4.9 Autotransformer

An autotransformer may be provided to allow operation on 190/230, 3–phase, 50/60 hertz power. The autotransformer raises the supply voltage to the nominal 380/460 volt power required by the base unit. The autotransformer may also be fitted with an individual circuit breaker for the 230 volt power. If the unit is equipped with an autotransformer and communications module, the autotransformer will be fitted with a transformer bridge unit (TBU) to assist in communications.

2.4.10 230 Volt Cable

Units equipped with an autotransformer require an additional power cable for connection to the 230 volt source. Various power cable and plug designs are available. The plug options tailor the cables to customer requirements.

2.4.11 Gutters

Rain gutters may be fitted over the control box to divert rain away from the controls.

2.4.12 Handles

The unit may be equipped with handles to facilitate access to stacked containers.

2.4.13 Thermometer Port

The unit may be fitted with ports in the front of the frame for insertion of a thermometer to measure supply and/or return air temperature. If fitted, the port(s) will require a cap and chain.

2.4.14 Back Panels

Aluminum back panels may have access doors and/or hinge mounting.

2.4.15 Cable Restraint

Various designs are available for storage of the power cables. These options are variations of the compressor section front cover.

2.4.16 Upper Air (Fresh Air Make Up)

The unit may be fitted with an upper fresh air makeup assembly. The fresh air makeup assembly is available with a vent positioning sensor (VPS) and may also be fitted with screens.

2.4.17 Lower Air (Fresh Air Make Up)

The unit may be fitted with a lower fresh air makeup assembly. The fresh air makeup assembly is available with a vent positioning sensor (VPS) and may also be fitted with screens.

2.4.18 Labels

Safety Instruction and Function Code listing labels differ depending on the options installed. Labels available with additional languages are listed in the parts list.

2.4.19 Display Module

The unit may be fitted with a backlit Liquid Crystal Display (LCD) or a Light Emitting Diode (LED) Display.

2.4.20 Emergency Bypass

The optional Emergency Bypass switch (EB) functions to bypass the controller in the event of controller failure.

2.4.21 eAutoFresh

The optional eAutoFresh venting system moderates the atmospheric level inside the container unit in response to cargo respiration.

2.4.22 Controlled Atmosphere

Controlled atmosphere units may be fitted with the TransFresh or the complete Carrier Transicold EverFresh option.

For information on the TransFresh system, contact TransFresh Corporation, P.O. Box 1788, Salinas CA 93902

The EverFresh option is the addition of the Carrier Transicold EverFresh controlled atmosphere system. This system continuously monitors and controls oxygen and carbon dioxide levels in the container.

SECTION 3 DESCRIPTION

3.1 GENERAL DESCRIPTION

3.1.1 Refrigeration Unit – Front Section

The unit is designed so that the majority of the components are accessible from the front (see [Figure 3.1](#)). The unit model number, serial number, and parts identification number can be found on the serial plate to the left of the compressor.

3.1.2 Fresh Air Makeup Vent

The function of the upper or lower makeup air vent is to provide ventilation for commodities that require fresh air circulation. A manually operated venting system is located in the upper left access panel. The optional eAutoFresh vent system is to moderate the atmospheric level in the container in response to cargo respiration. When transporting frozen cargo loads the vent will be closed. The upper left access panel contains the vent slide and motor assembly. It may be removed to allow entry into the evaporator section where the CO₂ sensor and drive pack are located.

Figure 3.1 Refrigeration Unit - Front Section

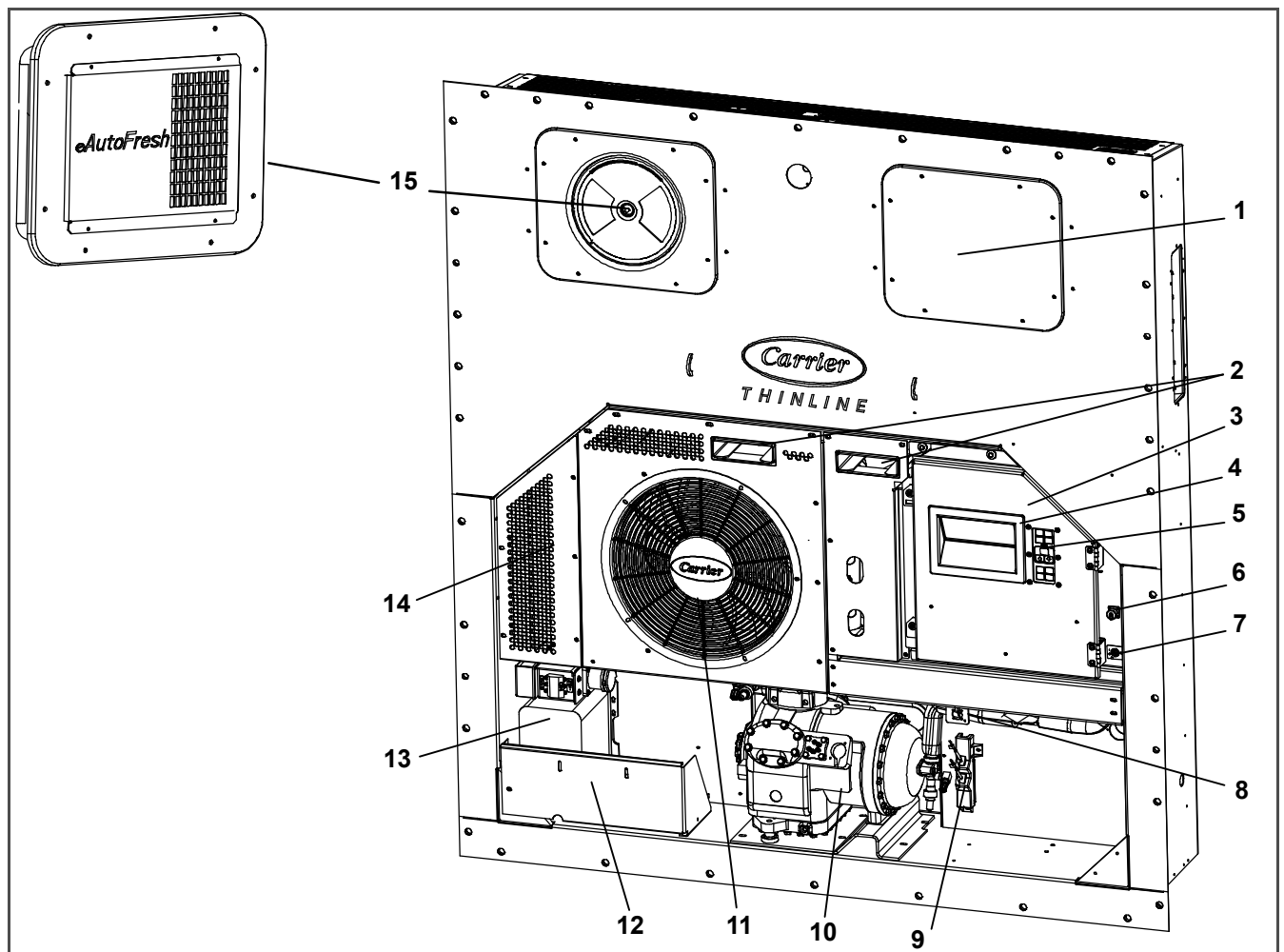

- | | |
|---|--|
| <ol style="list-style-type: none"> 1. Access Panel (Evap Fan #1) / TXV / HTT) 2. Fork Lift Pockets 3. Control Box 4. Unit Display 5. Control Panel 6. Remote Monitoring Receptacle 7. Start-Stop Switch, ST 8. Interrogator Connector | <ol style="list-style-type: none"> 9. Supply Temperature Supply/Recorder Sensor Assembly (STS/SRS) 10. Compressor 11. Condenser Grille 12. Power Cables and Plug (Location) 13. Autotransformer 14. Lower Fresh Air Makeup Vent Location (Blank Cover Shown) 15. Upper Fresh Air Makeup Vent or eAutoFresh (Automatic Vent) panel |
|---|--|

3.1.3 Evaporator Section

The evaporator section is shown below. The evaporator fans circulate air through the container by pulling it in the top of the unit, directing it through the evaporator coil where it is heated or cooled, and discharging it at the bottom.

If the unit is equipped with eAutoFresh, system components are mounted in addition to the standard refrigeration unit components. The stepper motor component is

installed in the vent; the air filter, CO₂ sensor, stepper motor drive and CO₂ sensing lines are installed on the rib of the upper grill.

Most evaporator components are accessible by removing the upper rear panel (as shown in the illustration) or by removing the evaporator fan access panels (see [Figure 3.1](#)).

Figure 3.2 Evaporator Section - Units with Center Access Panel

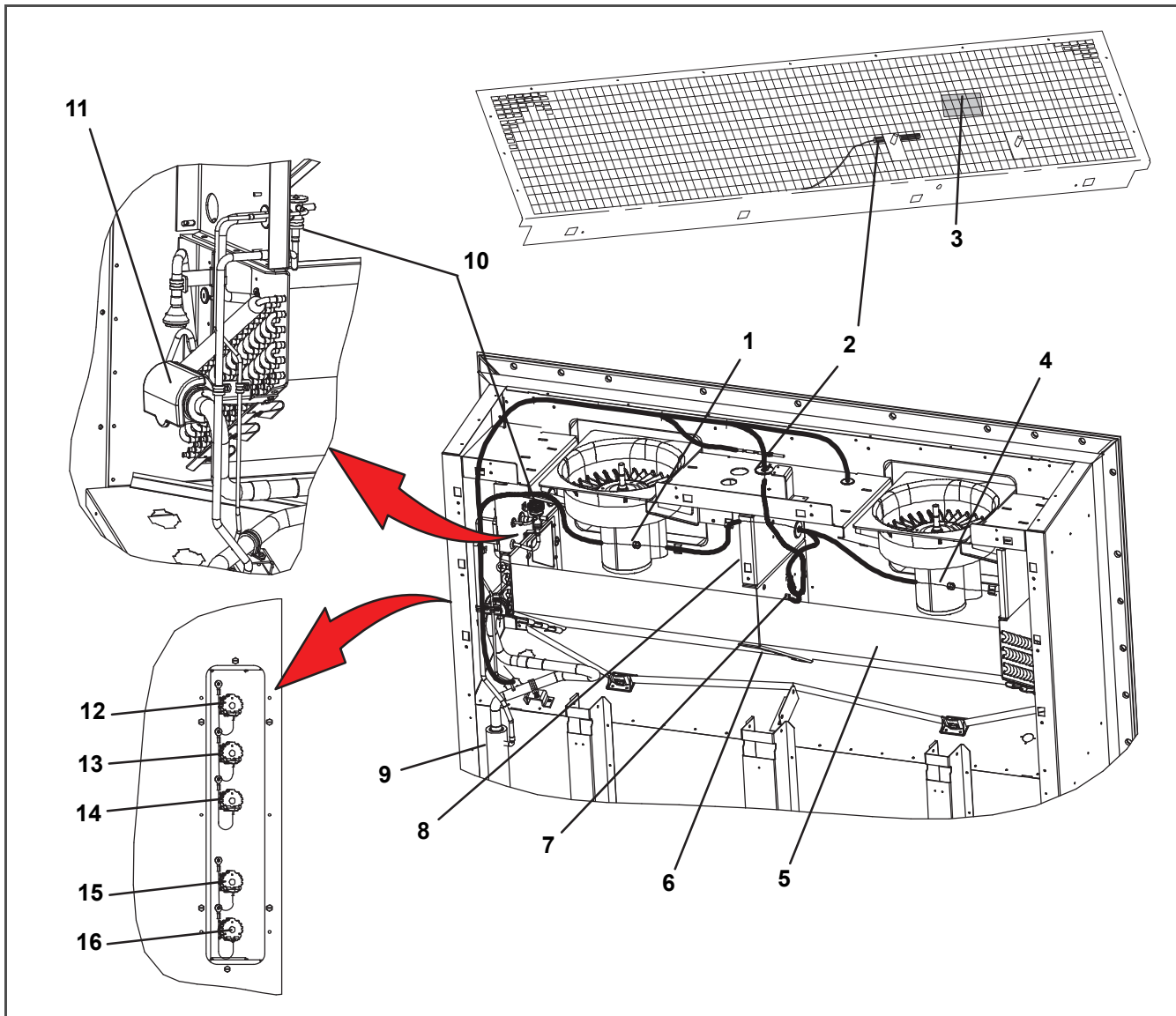

- | | |
|---|---|
| 1. Evaporator Fan Motor #1 | 9. Heat Exchanger |
| 2. Return Recorder Sensor (RRS) / Return Temperature Sensor (RTS) | 10. Thermostatic Expansion Valve (TXV) |
| 3. Humidity Sensor | 11. TXV Bulb |
| 4. Evaporator Fan Motor #2 | 12. Interrogator Connector (Rear) (ICR) |
| 5. Evaporator Coil | 13. USDA Probe Receptacle PR2 |
| 6. Evaporator Coil Heaters | 14. USDA Probe Receptacle PR1 |
| 7. Defrost Temperature Sensor (DTS) | 15. USDA Probe Receptacle PR3 |
| 8. Heater Termination Thermostat (HTT) | 16. Cargo Probe Receptacle PR4 |

3.1.4 Compressor Section

The compressor section includes the compressor (with high pressure switch), power cable storage compartment, and autotransformer.

This section also contains the quench valve, suction modulating valve, discharge pressure regulating valve, discharge temperature sensor, and discharge/suction pressure transducers.

The supply temperature sensor, supply recorder sensor, and ambient sensor are located at the right side of the compressor.

Figure 3.3 Compressor Section

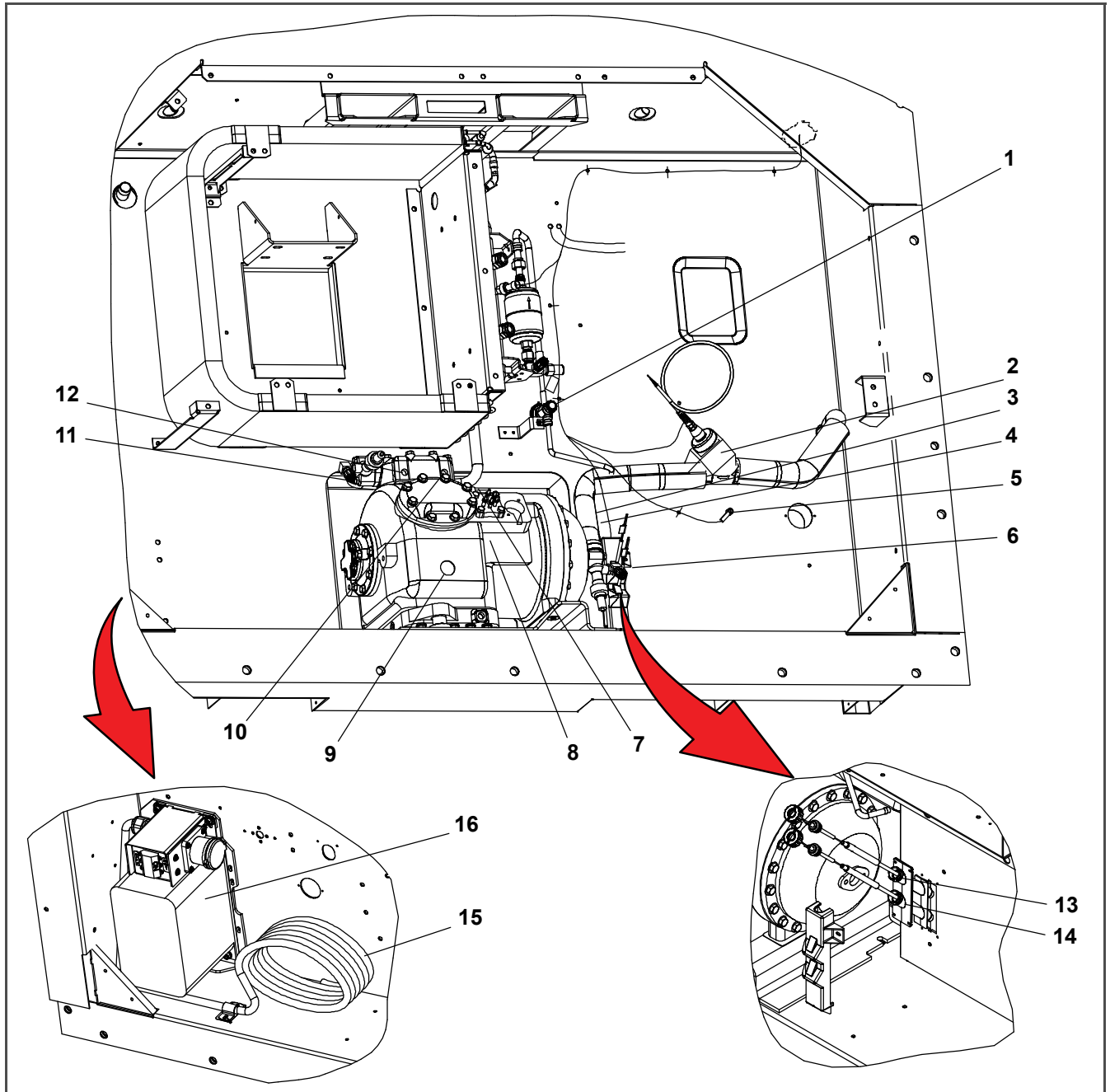

- | | |
|----------------------------------|-------------------------------------|
| 1. Quench Valve | 9. Compressor Sight Glass View Port |
| 2. Suction Modulating Valve | 10. Discharge Pressure Transducer |
| 3. Suction Temperature Sensor | 11. Discharge Service Valve |
| 4. Quench Valve Temperature Bulb | 12. High Pressure Switch |
| 5. Ambient Sensor | 13. Supply Temperature Sensor (STS) |
| 6. Suction Service Valve | 14. Supply Recorder Sensor |
| 7. Suction Pressure Transducer | 15. Power Cables and Plug |
| 8. Compressor | 16. Autotransformer |

3.1.5 Air-Cooled Condenser Section

The air-cooled condenser section (**Figure 3.4**) consists of the condenser fan, condenser coil, receiver with sight glass/moisture indicator, quench valve, liquid line

service valve, filter-drier, condenser pressure transducer, and fusible plug.

The condenser fan pulls air from around the coil and discharges it horizontally through the condenser fan grille.

Figure 3.4 Condenser Section

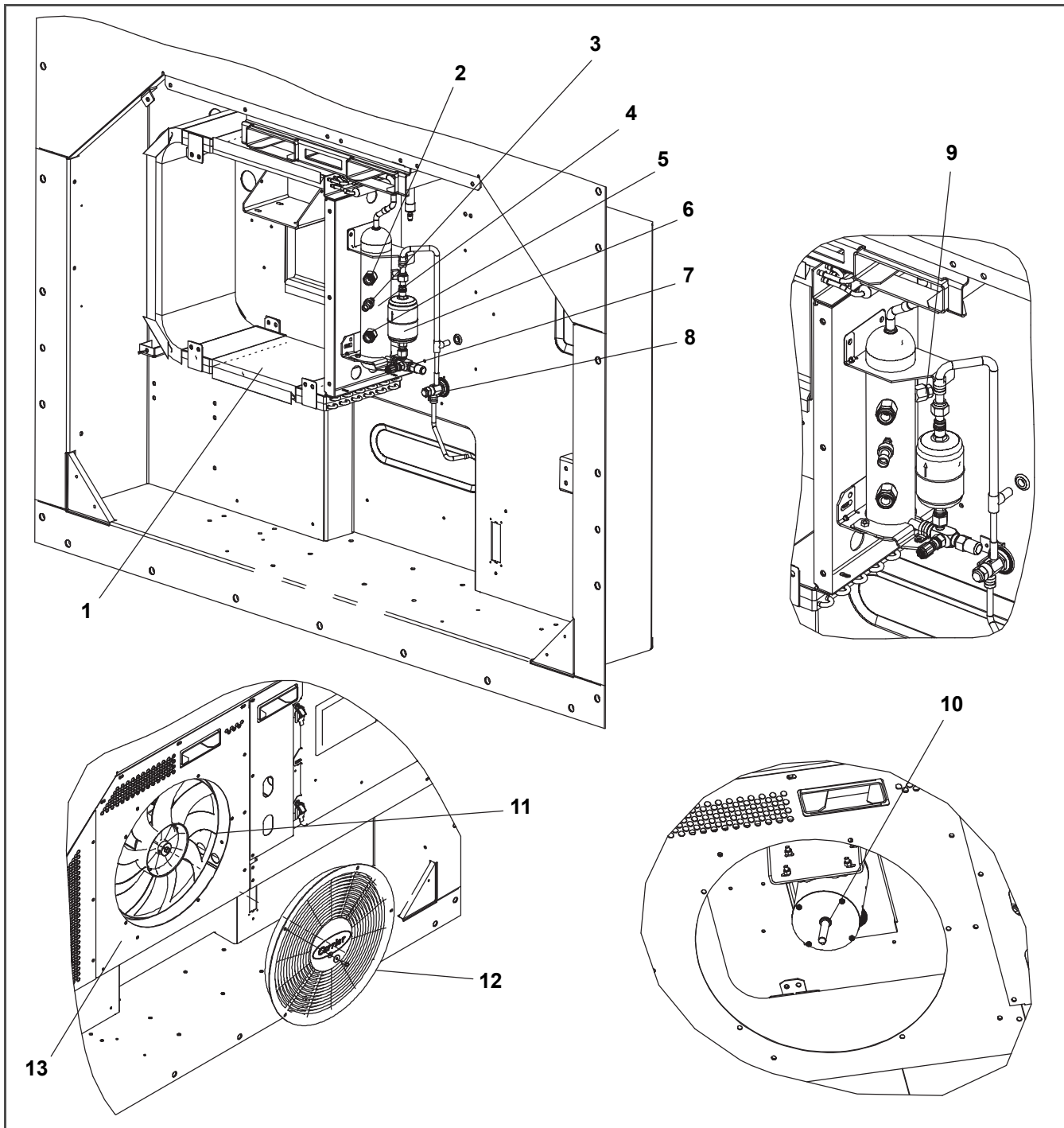

- | | |
|-----------------------------------|--------------------------|
| 1. Condenser Coil | 8. Quench Valve |
| 2. Sight Glass | 9. Fusible Plug |
| 3. Condenser Pressure Transducer | 10. Condenser Fan Motor |
| 4. Receiver | 11. Condenser Fan |
| 5. Sight Glass/Moisture Indicator | 12. Condenser Grille |
| 6. Filter-Drier | 13. Condenser Coil Cover |
| 7. Liquid Line Service Valve | |

3.1.6 Control Box Section

The control box (**Figure 3.5**) includes the manual operation switches, circuit breaker (CB-1), compressor, fan and heater contactors, control power transformer, current sensor module, controller module and the communications interface module.

3.1.7 Communications Interface Module (option)

The communications interface module is a slave module which allows communication between the refrigeration unit and a ship system master central monitoring station. The module will respond to communication, and return information over the ships main power line. Refer to the master system technical manual for further information.

Figure 3.5 Control Box Section

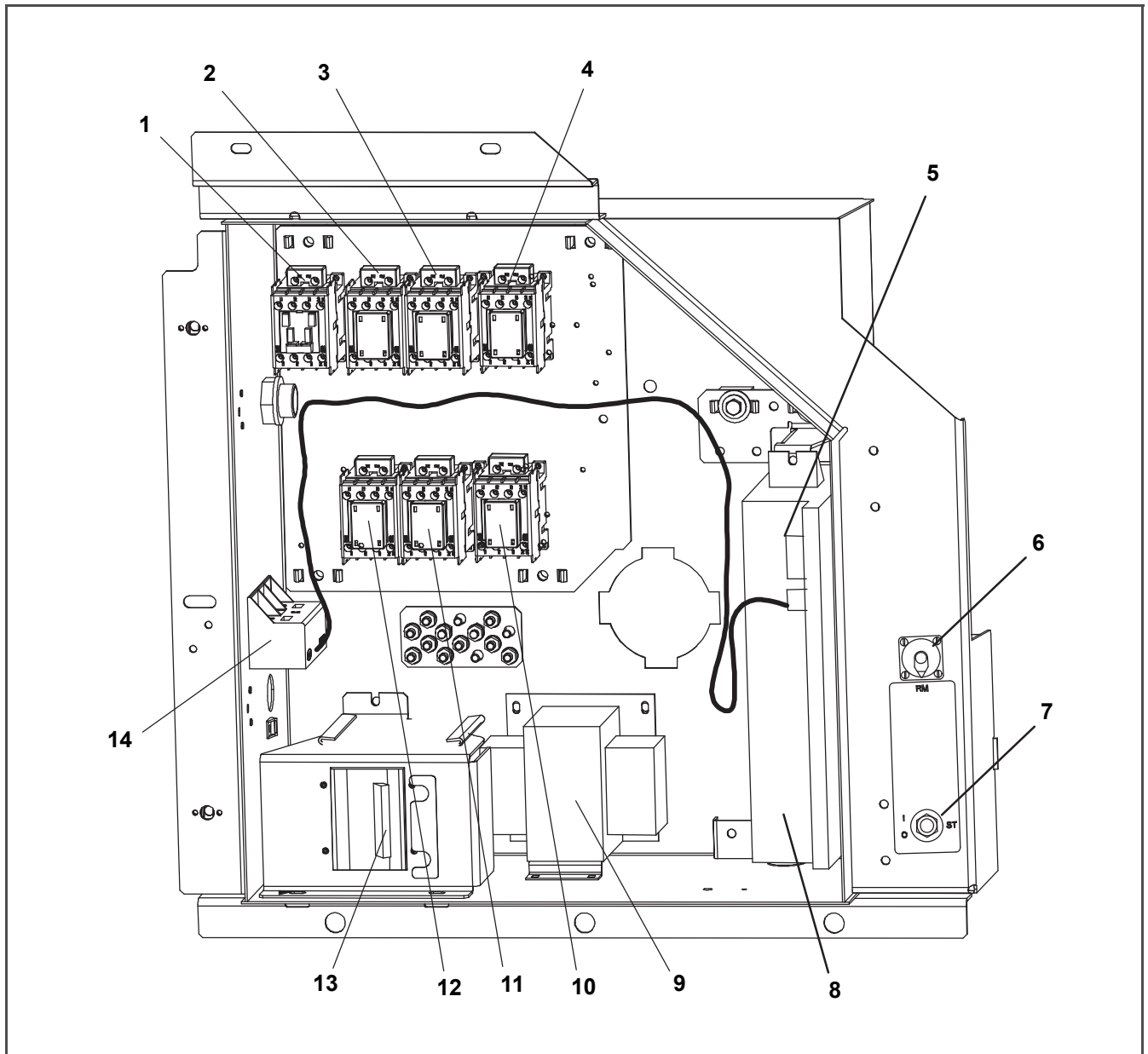

- | | |
|--|--|
| 1. Compressor Contactor – CH | 8. Controller Battery Pack (Standard Location) |
| 2. Compressor Phase A Contactor – PA | 9. Control Transformer |
| 3. Compressor Phase B Contactor – PB | 10. High Speed Evaporator Fan Contactor – EF |
| 4. Heater Contactor – HR | 11. Low Speed Evaporator Fan Contactor – ES |
| 5. Controller/DataCORDER Module (Controller) | 12. Condenser Fan Contactor – CF |
| 6. Remote Monitoring Receptacle | 13. Circuit Breaker (CB1) – 460V |
| 7. Start–Stop Switch, ST | 14. Current Sensor Module |

3.2 REFRIGERATION SYSTEM DATA

| | | |
|---|--|--|
| a. Compressor/Motor Assembly | Number of Cylinders | 6 |
| | Model | 06DR |
| | CFM | 41 |
| | Weight (Dry) | 118kg (260 lb) |
| | Approved Oil | Castrol Icematic |
| | Oil Charge degrees | 3.6 liters (7.6 U.S. pints) |
| | Oil Sight Glass | The oil level range, with the compressor off, should be between the bottom and one-eighth level of the sight glass. |
| b. Expansion Valve Super-heat | Verify at -18C (0°F) container box temperature | 4.4 to 6.7°C (8 to 12°F) |
| c. Heater Termination Thermostat | Opens | 54° (+/- 3) C = 130° (+/- 5) F |
| | Closes | 38° (+/- 4) C = 100° (+/- 7) F |
| d. High Pressure Switch | Cutout | 25 (+/- 1.0) kg/cm ² = 350 (+/- 10) psig |
| | Cut-In | 18 (+/- 0.7) kg/cm ² = 250 (+/- 10) psig |
| <div style="background-color: #e67e22; color: white; padding: 5px; display: inline-block; border: 1px solid black;">  WARNING </div> <p>EXPLOSION HAZARD: Failure to follow this WARNING can result in death, serious personal injury and / or property damage.</p> <p>Never use air or gas mixtures containing oxygen (O₂) for leak testing or operating the product.</p> <p>Charge Only With R-134a: Refrigerant must conform to AHRI Standard 700 specification.</p> | | |
| e. Refrigerant | R-134a | Conforming to AHRI standard 700 specifications. |
| f. Refrigerant Charge | Unit Configuration | Charge Requirements – R-134a |
| | Receiver | 3.3 kg (7.3 lbs) |
| <p>N</p> <p>When replacing components (g.) and (h.), refer to installation instructions included with replacement part.</p> | | |
| g. Fusible Plug, Receiver* | Melting point | 99°C = (210°F) |
| | Torque* | 6.2 to 6.9mkg (45 to 50ft-lbs) |
| h. Sight Glass/Moisture Indicator | Torque | 8.9 to 9.7mkg (65 to 70ft-lbs) |
| i. Condenser Pressure Transducer | Condenser Fan Starts | Condenser fan will start if condenser pressure is greater than 14.06kg/cm ² (200psig) OR the condenser fan is OFF for more than 60 seconds. |
| | Condenser Fan Stops | Condenser fan will stop if condenser pressure is less than 9.14kg/cm ² (130psig) AND the condenser fan remains ON for at least 30 seconds. |
| j. Unit Weight | Refer to unit model number plate. | |

* Rupture Disc, part number 14 -00215 -04 may be installed as an alternate for the receiver mounted fusible plug.

3.3 ELECTRICAL DATA

| | | | |
|-----------------------------------|---------------------------------|---|--|
| a. Circuit Breaker | CB-1 | Trips at 29 amps | |
| | CB-2 (50 amps) | Trips at 62.5amps | |
| | CB-2 (70 amp) | Trips at 87.5amps | |
| b. Compressor Motor | Full Load Amps (FLA) | 17.6amps @ 460VAC (with current limiting set at 21 amps) | |
| c. Condenser Fan Motor | Nominal Supply | 380 VAC, Three Phase, 50 Hz | 460 VAC, Three Phase, 60 Hz |
| | Full Load Amps | .71 amps | .72 amps |
| | Horsepower | 0.21 hp | 0.36 hp |
| | Rotations Per Minute | 1450 rpm | 1750 rpm |
| | Voltage and Frequency | 360 – 460 VAC +/- 2.5 Hz | 400 – 500 VAC +/- 2.5 Hz |
| | Bearing Lubrication | Factory lubricated, additional grease not required. | |
| | Rotation | Counter-clockwise when viewed from shaft end. | |
| d. Evaporator Coil Heaters | Number of Heaters | 6 | |
| | Rating | 750 watts +5/-10% each @ 230 VAC | |
| | Resistance (cold) | 66.8 to 77.2 ohms @ 20°C (68°F) | |
| | Type | Sheath | |
| e. Evaporator Fan Motor(s) | | 380 VAC/3 PH/50 Hz | 460 VAC/3 PH/60 Hz |
| | Full Load Amps High Speed | 1.07 | 0.9 |
| | Full Load Amps Low Speed | 0.47 | 0.47 |
| | Nominal Horsepower High Speed | 0.36 | 0.63 |
| | Nominal Horsepower Low Speed | 0.05 | 0.8 |
| | Rotations Per Minute High Speed | 2850 rpm | 3450 rpm |
| | Rotations Per Minute Low Speed | 1425 rpm | 1725 rpm |
| | Voltage and Frequency | 360 – 460 VAC +/- 1.25 Hz | 400 – 500 VAC +/- 1.5 Hz |
| | Bearing Lubrication | Factory lubricated, additional grease not required | |
| | Rotation | CW when viewed from shaft end | |
| f. Fuses | Control Circuit | 7.5 amps (F3A, F3B) | |
| | Controller/DataCORDER | 5 amps (F1 & F2) | |
| g. Vent Positioning Sensor | Electrical Output | 0.5 VDC to 4.5 VDC over 90 degree range | |
| | Supply Voltage | 5 VDC +/- 10% | |
| | Supply Current | 5 mA (typical) | |

| ELECTRICAL DATA (Continued) | | |
|------------------------------------|--|-----------------------------|
| h. Humidity Sensor | Orange wire | Power |
| | Red wire | Output |
| | Brown wire | Ground |
| | Input voltage | 5 vdc |
| | Output voltage | 0 to 3.3 vdc |
| | Output voltage readings verses relative humidity (RH) percentage: | |
| | 30% | 0.99V |
| | 50% | 1.65V |
| | 70% | 2.31V |
| | 90% | 2.97V |
| i. Controller | Setpoint Range | -30 to +30°C (-22 to +86°F) |

3.4 SAFETY AND PROTECTIVE DEVICES

Unit components are protected from damage by safety and protective devices listed in the following table. These devices monitor the unit operating conditions and open a set of electrical contacts when an unsafe condition occurs.

Table 3-1 Safety and Protective Devices

| UNSAFE CONDITION | SAFETY DEVICE | DEVICE SETTING |
|--|---|---|
| Excessive current draw | Circuit Breaker (CB-1) – Manual Reset | Trips at 29 amps (460VAC) |
| | Circuit Breaker (CB-2, 50 amp) –Manual Reset | Trips at 62.5 amps (230VAC) |
| | Circuit Breaker (CB-2, 70 amp) –Manual Reset | Trips at 87.5 amps (230VAC) |
| Excessive current draw in control circuit | Fuse (F3A & F3B) | 7.5 amp rating |
| Excessive current draw by controller | Fuse (F1 & F2) | 5 amp rating |
| Excessive condenser fan motor winding temperature | Internal Protector (IP-CM) – Automatic Reset | N/A |
| Excessive compressor motor winding temperature | Internal Protector (IP-CP) – Automatic Reset | N/A |
| Excessive evaporator fan motor(s) winding temperature | Internal Protector(s) (IP-EM) – Automatic Reset | N/A |
| Abnormal pressures / temperatures in the high refrigerant side | Fusible Plug – Receiver | 99°C = (210°F) |
| Abnormally high discharge pressure | High Pressure Switch (HPS) – Automatic Reset | Open at 25kg/cm@ (350psig) Close at 18kg/cm@ (250psig) |

3.5 REFRIGERATION CIRCUIT

Starting at the compressor (see [Figure 3.6](#)), the suction gas is compressed to a higher pressure and temperature.

The gas flows out the compressor through the discharge service valve. Refrigerant gas then moves into the air-cooled condenser, where air flowing across the coil fins and tubes cools the gas to saturation temperature. By removing latent heat, the gas condenses to a high pressure/high temperature liquid and flows to the receiver, which stores the additional charge necessary for low temperature operation.

The liquid refrigerant continues through the liquid line service valve, the filter-drier (which keeps refrigerant clean and dry), and a heat exchanger (that increases subcooling of the liquid) to the thermostatic expansion valve (TXV).

As the liquid refrigerant passes through the variable orifice of the TXV, the pressure drops to suction pressure. In this process some of the liquid vaporizes to a gas (flash gas), removing heat from the remaining liquid. The liquid exits as a low pressure, low temperature, saturated mix. Heat is then absorbed from the return air by the balance of the liquid, causing it to vaporize in the evaporator coil. The vapor then flows through the suction tube back to the compressor.

The TXV is activated by the bulb strapped to the suction line near the evaporator outlet. The valve maintains a constant superheat at the coil outlet regardless of load conditions.

The TXV is a mechanical device that regulates the flow of liquid to the evaporator coil in order to maintain a relatively constant degree of superheat in the gas leaving the evaporator regardless of suction pressure.

The flow of liquid to the evaporator is regulated by a variable orifice which opens to increase refrigerant flow (decrease superheat), or closes to decrease refrigerant flow (increase superheat). The variable orifice is controlled by the temperature sensing bulb which is strapped to the suction line near the evaporator outlet.

During periods of low load, the suction modulating valve (SMV) decreases flow of refrigerant to the compressor. This action balances the compressor capacity with the load and prevents operation with low coil temperatures. In this mode of operation, the quench valve will open as required to provide sufficient liquid refrigerant flow into the suction line for cooling of the compressor motor. The quench valve senses refrigerant condition entering the compressor and modulates the flow to prevent entrance of liquid into the compressor.

The refrigeration system is also fitted with a condenser pressure transducer, which feeds information to the controller. The controller programming will operate the condenser fan so as to attempt to maintain discharge pressures above 130psig in low ambients. At ambients below 27°C (80°F), the condenser fan will cycle on and off depending on condenser pressure and operating times.

1. The condenser fan will start if the condenser pressure is greater than 200psig OR the condenser fan has been OFF for more than 60 seconds.
2. The condenser fan will stop if the condenser pressure is less than 130psig AND the condenser fan has been running for at least 30 seconds.

At ambients above 27°C (80°F), condenser pressure control is disabled and the condenser fan runs continuously.

Figure 3.6 Refrigeration Circuit Schematic

Refrigeration Circuit with Receiver

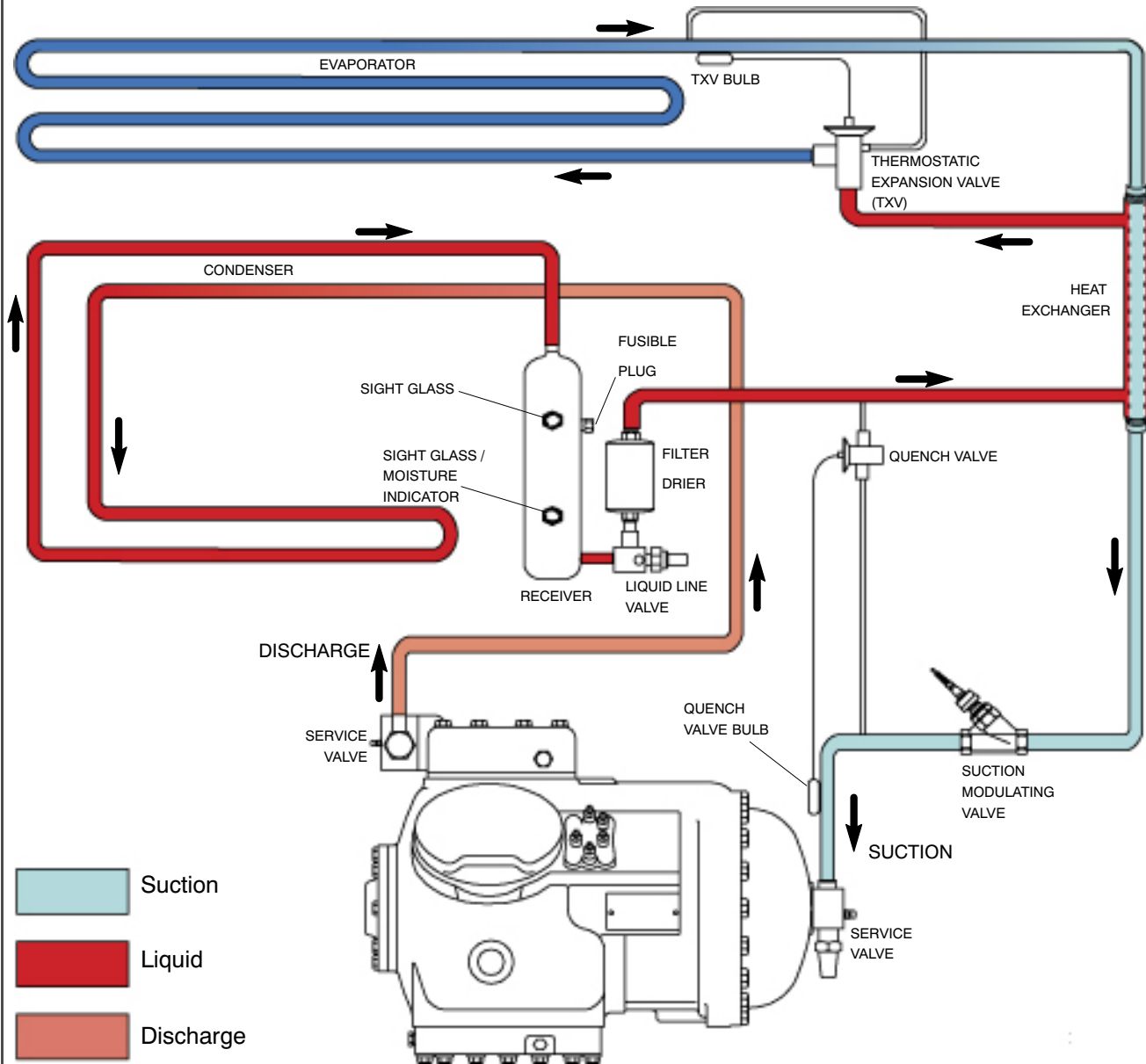

SECTION 4 MICROPROCESSOR

4.1 TEMPERATURE CONTROL MICROPROCESSOR SYSTEM

The temperature control Micro-Link 3 microprocessor system (see [Figure 4.1](#)) consists of a keypad, display module, control module (controller), and interconnecting wiring. The controller houses the temperature control software and the DataCORDER Software. The temperature control software functions to operate the unit components as required to provide the desired cargo temperature and humidity.

The DataCORDER software functions to record unit operating parameters and cargo temperature parameters for future retrieval. Coverage of the temperature control software begins with [Section 4.2](#). Coverage of the DataCORDER software is provided in [Section 4.8](#).

The keypad and display module serve to provide user access and readouts for both of the controller functions, temperature control, and DataCORDER. The functions are accessed by keypad selections and viewed on the display module. The components are designed to permit ease of installation and removal.

Figure 4.1 Temperature Control System

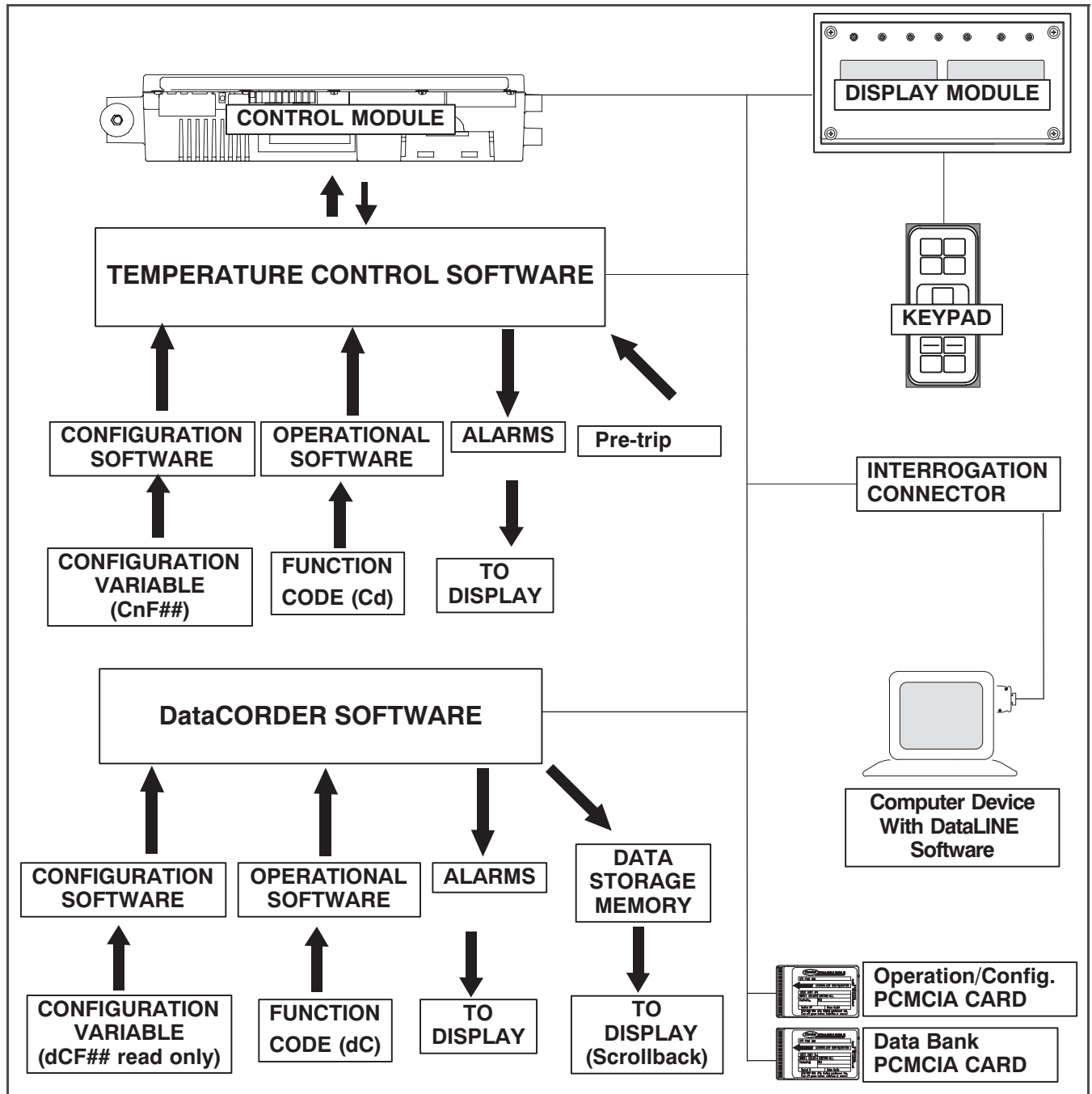

4.1.1 Keypad

The keypad (**Figure 4.2**) is mounted on the control box door. The keypad consists of 11 push button switches that act as the user's interface with the controller. Descriptions of the switch functions are provided in **Table 4-1**.

Figure 4.2 Keypad

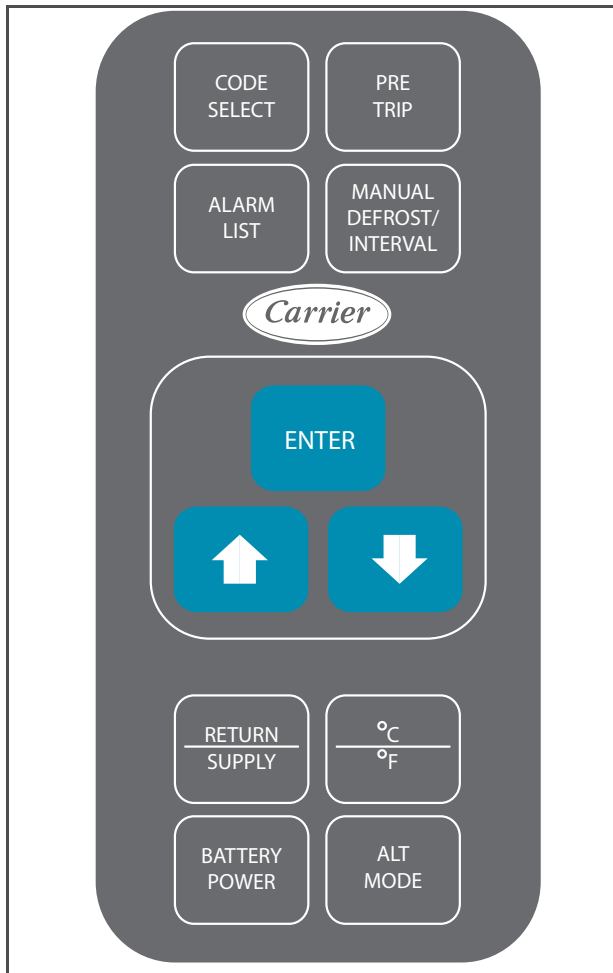

4.1.2 Display Module

The display module (**Figure 4-3**) consists of five digital displays and seven indicator lights. Indicator lights include:

1. COOL – White or Blue LED: Energized when the refrigerant compressor is energized.
2. HEAT – Orange LED: Energized to indicate heater operation in heat mode, defrost mode, or dehumidification.
3. DEFROST – Orange LED: Energized when the unit is in the defrost mode.
4. IN RANGE – Green LED: Energized when the controlled temperature probe is within specified tolerance of set point.

NOTE

The controlling probe in perishable range is the SUPPLY air probe and the controlling probe in frozen range is the RETURN air probe.

5. SUPPLY – Yellow LED: Energized when the supply air probe is used for control. When this LED is illuminated, the temperature displayed in the AIR TEMPERATURE display is the reading at the supply air probe. This LED will flash if dehumidification or humidification is enabled.
6. RETURN – Yellow LED: Energized when the return air probe is used for control. When this LED is illuminated, the temperature displayed in the AIR TEMPERATURE display is the reading at the return air probe. This LED will flash if dehumidification or humidification is enabled.
7. ALARM – Red LED: Energized when an active or an inactive shutdown alarm is in the alarm queue.

Table 4-1 Keypad Function

| KEY | FUNCTION |
|---------------------------|---|
| CODE SELECT | Accesses function codes. |
| PRE TRIP | Displays the pre-trip selection menu. Discontinues pre-trip in progress. |
| ALARM LIST | Displays alarm list and clears the alarm queue. |
| MANUAL DEFROST / INTERVAL | Displays selected defrost mode. Depressing and holding the Defrost interval key for five seconds will initiate defrost using the same logic as if the optional manual defrost switch was toggled on. |
| ENTER | Confirms a selection or saves a selection to the controller. |
| Arrow Up | Change or scroll a selection upward. Pre-trip advance or test interruption. |
| Arrow Down | Change or scroll a selection downward. Pre-trip repeat backward |
| RETURN / SUPPLY | Displays non-controlling probe temperature (momentary display). |
| Celsius / Fahrenheit | Displays alternate English/Metric scale (momentary display). When set to degrees Fahrenheit, pressure is displayed in psig and vacuum in "/hg. "P" appears after the value to indicate psig and "i" appears for inches of mercury. When set to degrees Celsius, pressure readings are in bars. "b" appears after the value to indicate bars. |
| BATTERY POWER | Initiate battery backup mode to allow set point and function code selection if AC power is not connected. |
| ALT MODE | This key is pressed to switch the functions from the temperature software to the DataCORDER Software. The remaining keys function the same as described above except the readings or changes are made to the DataCORDER programming. |

Figure 4.3 Display Module

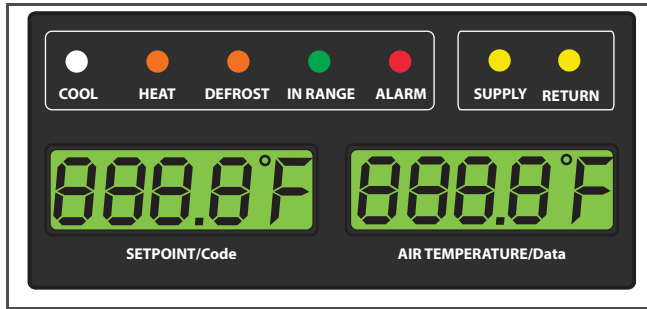

4.1.3 Controller

CAUTION

Do not remove wire harnesses from controller unless you are grounded to the unit frame with a static safe wrist strap.

CAUTION

Unplug all controller wire harness connectors before performing arc welding on any part of the container.

CAUTION

Do not attempt to use an ML2i PC card in an ML3 equipped unit. The PC cards are physically different and will result in damage to the controller.

NOTE

Do not attempt to service the controller. Breaking the seal will void the warranty.

The Micro-Link 3 controller is a single module micro-processor as shown in Figure 4.4. It is fitted with test points, harness connectors and a software card programming port.

4.2 CONTROLLER SOFTWARE

The controller software is a custom designed program that is subdivided into the configuration software and the operational software. The controller software performs the following functions:

- Control supply or return air temperature to required limits, provide modulated refrigeration operation, economized operation, unloaded operation, electric heat control, and defrost. Defrost is performed to clear buildup of frost and ice to ensure proper air flow across the evaporator coil.
- Provide default independent readouts of set point and supply or return air temperatures.
- Provide ability to read, and if applicable, modify the configuration software variables, operating software function codes, and alarm code indications.
- Provide a Pre-trip step-by-step checkout of refrigeration unit performance, including proper component operation, electronic and refrigeration control operation, heater operation, probe calibration, pressure limiting, and current limiting settings.
- Provide battery-powered ability to access or change selected codes and set points without AC power connected.
- Provide the ability to reprogram the software through the use of a memory card.

4.2.1 Configuration Software (CnF Variables)

The configuration software is a variable listing of the components available for use by the operational software. This software is factory-installed in accordance with the equipment fitted and options listed on the original purchase order. Changes to the configuration software are required only when a new controller has been installed or a physical change has been made to the unit such as the addition or removal of an option. A configuration variable list is provided in Table 4-4. Change to the factory-installed configuration software is achieved via a configuration card or by communications.

Figure 4.4 Control Module

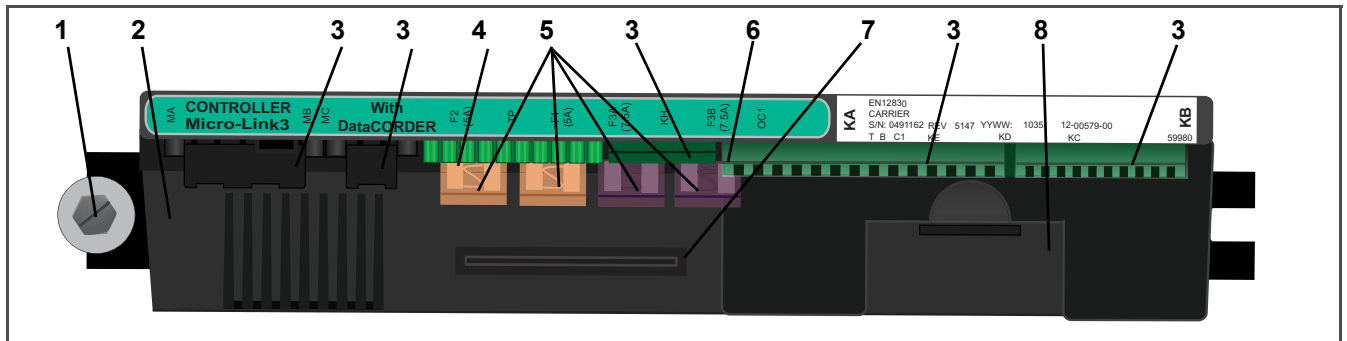

1. Mounting Screw
2. Micro-Link 3 Controller
3. Connectors
4. Test Points
5. Fuses
6. Control Circuit Power Connection (located on back of controller)
7. Software Programming Port
8. Battery Pack

4.2.2 Operational Software (Cd Function Codes)

The operational software is the actual operation programming of the controller which activates or deactivates components in accordance with current unit operation conditions and selected modes of operation.

The programming is divided into function codes. Some of the codes are read only, while the remaining codes may be user configured. The value of the user configurable codes can be assigned in accordance with user desired mode of operation. A list of the function codes is provided in [Table 4–5](#).

To access the function codes:

- a. Press CODE SELECT, then press an arrow key until the left window displays the desired function code.
- b. The right window will display the selected function code value for five seconds before returning to the default display mode.
- c. If additional time is required, pressing the ENTER key will extend the display time to 30 seconds.

4.3 MODES OF OPERATION

General operation sequences for cooling, heating, and defrost are provided in the following sub-paragraphs. Schematic representation of controller actions are provided in [Figure 4.5](#) & [Figure 4.8](#).

Operational software responds to various inputs. These inputs come from the temperature sensors and pressure transducers, the temperature set point, the settings of the configuration variables and the function code assignments. The action taken by the operational software changes as the input values change. Overall interaction of the inputs is described as a “mode” of operation. The modes of operation include perishable (chill) mode and frozen mode. Descriptions of the controller interaction and modes of operation are provided in the following sub paragraphs.

4.3.1 Perishable Mode Temperature Control

The unit is capable of maintaining supply air temperature to within +/- 0.25°C (+/- 0.5°F) of set point. Supply air temperature is controlled by positioning of the suction modulation valve (SMV), cycling of the compressor, and cycling of the heaters.

In Perishable Mode, the controller maintains the supply air temperature at set point, the SUPPLY indicator light is illuminated and the default reading on the display window is the supply temperature sensor reading.

When the supply air temperature enters the in-range temperature tolerance (Cd30), the green IN-RANGE light will energize.

When CnF26 (Heat Lockout Temperature) is set to -10°C, perishable mode is active with set points above -10°C (+14°F). When CnF26 is set to -5°C, perishable mode is active with set points above -5°C (+23°F).

4.3.2 Perishable Pulldown

When the system is in Perishable Pulldown Mode, the highest priority is given to bringing the container down to set point. When cooling from a temperature that is more than 5°C (9°F) above set point, the system will be in Perishable Pulldown Mode, and the SMV will open to reduce the pulldown time.

However, pressure and current limit functions may restrict the valve if either exceeds the preset limits.

4.3.3 Perishable Steady State

Perishable Steady State is used to maintain the control temperature near a setpoint that is above the heat lockout temperature.

The operational software is designed so the SMV will begin to close as the set point is reached. The SMV will continue to close and restrict refrigerant flow until the capacity of the unit and the load are balanced.

If the temperature drops below the set point, the compressor will remain running for a few minutes. This is to accommodate any initial undershoot which might occur. After this time has expired and the temperature is 0.2°C (0.36°F) or greater below the set point, the compressor will be turned OFF.

If the temperature drops to 0.5°C (0.9°F) below set point, the heaters will be energized. The heaters will de-energize when the temperature rises to 0.2°C (0.36°F) below the set point. The compressor will not restart until the temperature rises to 0.2°C (0.36°F) above the set point and three minutes have elapsed since the last compressor turn off.

4.3.4 Perishable Idle, Air Circulation

Perishable Idle Mode is used when it is unnecessary to run the compressor to maintain control temperature. If the controller has determined that cooling is not required or the controller logic determines suction pressure is at the low pressure limit, the unit will transition to Perishable Idle Mode. During Perishable Idle Mode, the compressor is turned off, but the evaporator fans continue to run to circulate air throughout the container. If temperature rises +0.2°C above set point, the unit will transition back to perishable steady state.

4.3.5 Perishable Heating

When it is necessary to raise the control temperature, the system will enter Perishable Heating Mode. If the temperature drops to 0.5°C (0.9°F) below set point, the unit will transition to Perishable Heating Mode, and the heaters will be energized. The unit will transition back to Perishable Idle Mode when the temperature rises to 0.2°C (0.36°F) below the set point, and the heaters will de-energize.

Figure 4.5 Controller Operation - Perishable Mode

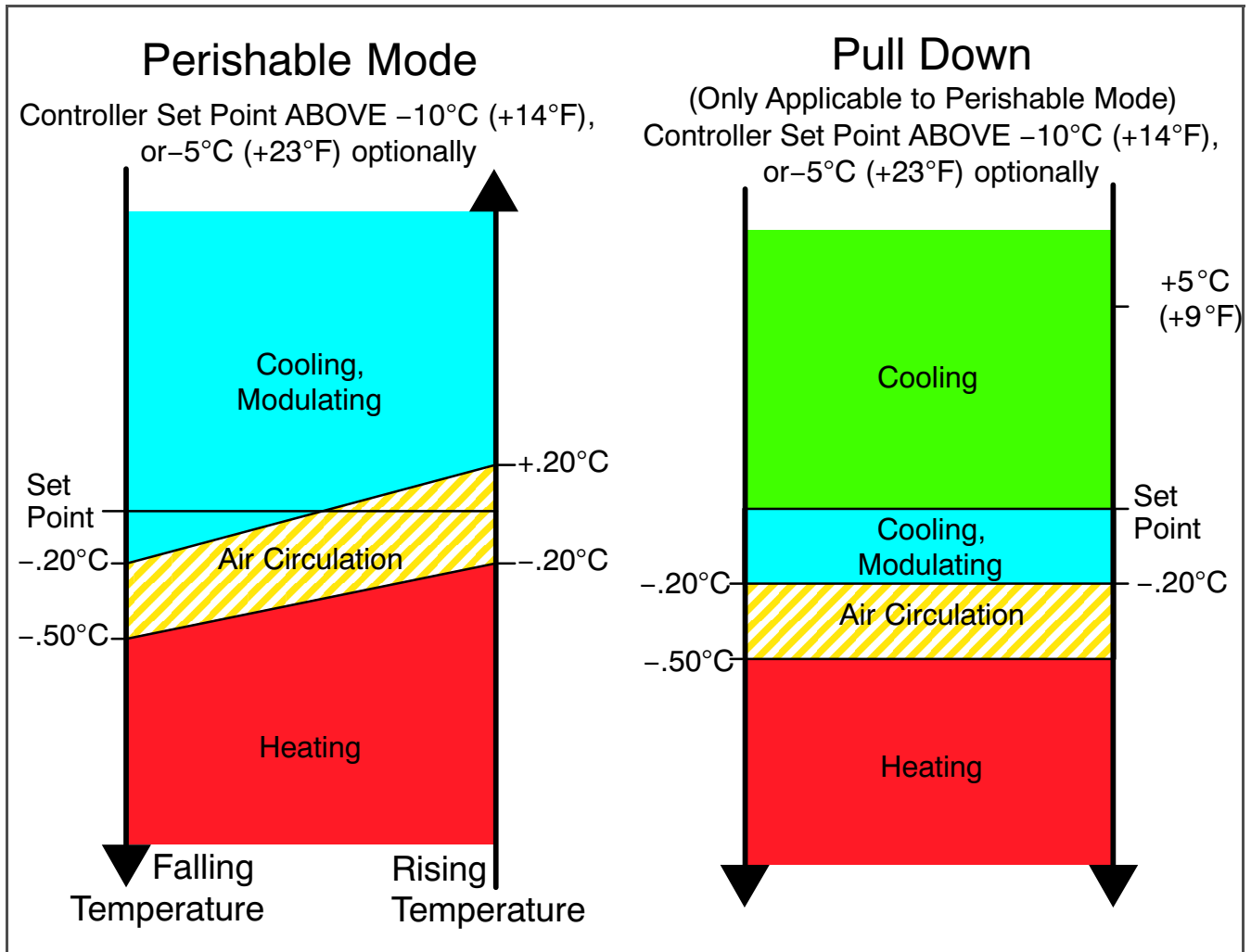

4.3.6 Perishable Mode Dehumidification

Dehumidification is provided to reduce the humidity levels inside the container. Dehumidification is activated when a humidity value is set at Cd33. The yellow SUPPLY LED will flash ON and OFF every second to indicate that dehumidification is active. Once dehumidification is active and the following conditions are satisfied, the controller will activate the heat relay to begin dehumidification.

1. The humidity sensor reading is above the humidity set point (Cd33).
2. The unit is in the perishable steady state mode, and the supply air temperature is less than 0.25°C (0.45°F) above set point.
3. The heater debounce timer (three minutes) has timed out.
4. Heater termination thermostat (HTT) is closed.

If the above conditions remain true for at least one hour, the evaporator fans will switch from high speed to low speed. Evaporator fan speed will then switch every hour, as long as the 4 conditions are met (see Bulb Mode, [Section 4.3.7](#) for different evaporator fan speed options).

If any condition except for item (1) becomes false OR if the relative humidity sensed is 2% below the dehumidification set point, the high speed evaporator fans will be energized.

During dehumidification, power is applied to the defrost heaters. This added heat load causes the controller to open the SMV to match the increased heat load while still holding the supply air temperature very close to the set point.

Opening the SMV reduces the temperature of the evaporator coil surface, which increases the rate at which water is condensed from the passing air. Removing water from the air reduces the relative humidity. When the relative humidity sensed is 2% below set point, the controller de-energizes the heat relay. The controller will continue to cycle heating to maintain relative humidity below the selected set point. If the dehumidification mode is terminated by a condition other than the humidity sensor, e.g., an out-of-range or compressor shutdown condition, the heat relay is de-energized immediately.

Two timers are activated during dehumidification to prevent rapid cycling and consequent contactor wear:

1. Heater debounce timer (three minutes) – The heater debounce timer is started whenever the heater contactor status is changed. The heat contactor remains energized (or de-energized) for at least three minutes even if the set point criteria is satisfied.
2. Out-of-range timer (five minutes) – The out-of-range timer is started to maintain heater operation during a temporary out-of-range condition. If supply air temperature remains outside of the user selected in-range setting for more than five minutes, the heaters will be de-energized to allow the system to recover. The out-of-range timer starts as soon as the temperature exceeds the in-range tolerance value set by Cd30.

4.3.7 Perishable, Dehumidification – Bulb Mode

Bulb mode is an extension of dehumidification which allows changes to the evaporator fan speed and/or defrost termination set points.

Bulb mode is active when Cd35 is set to “Bulb.” Once bulb mode is activated, the user may then change the dehumidification mode evaporator fan operation from the default (speed alternates from low to high each hour) to constant low or constant high speed. This is done by toggling Cd36 from its default of “alt” to “Lo” or “Hi” as desired. If low speed evaporator fan operation is selected, the user has the additional capability of selecting dehumidification set points from 60 to 95% (instead of the normal 65 to 95%).

In addition, if bulb mode is active, Cd37 may be set to override the previous defrost termination thermostat (DTT) settings. The temperature at which the DTT will be considered “open” may be changed [in 0.1°C (0.2°F) increments] to any value between 25.6°C (78°F) and 4°C (39.2°F). The temperature at which the DTT is considered closed for interval timer start or demand defrost is 10°C (50°F) for “open” values from 25.6°C (78°F) down to a 10°C (50°F) setting. For “open” values lower than 10°C, the “closed” values will decrease to the same value as the “open” setting. Bulb mode is terminated when:

1. Bulb mode code Cd35 is set to “Nor.”
2. Dehumidification code Cd33 is set to “Off.”
3. The user changes the set point to one that is in the frozen range.

When bulb mode is disabled by any of the above, the evaporator fan operation for dehumidification reverts to “alt” and the DTS termination setting resets to the value determined by CnF41.

4.3.8 Perishable Economy

Economy fan mode is an extension of the Perishable Mode, and is provided for power saving purposes. Economy fan mode is activated when Cd34 (also used for Frozen Economy Mode) is set to “ON.” Economy fan mode is used in the transportation of temperature-

tolerant cargo or non-respiration items which do not require high airflow for removing respiration heat.

There is no active display that indicates that economy fan mode has been initiated. To check for economy fan mode, perform a manual display of Cd34.

In order to achieve economy mode, a perishable set point must be selected prior to activation. When economy mode is active, the evaporator fans will be controlled as follows:

At the start of each cooling or heating cycle, the evaporator fans will run in high speed for three minutes.

After the initial three minutes, they will then be switched to low speed any time supply air temperature is within $\pm 0.25^{\circ}\text{C}$ (0.45°F) of set point and return air temperature is less than or equal to supply air temperature $+3^{\circ}\text{C}$ (5.4°F).

The fans will continue to run in low speed for one hour. At the end of the hour, the evaporator fans will switch back to high speed and the cycle will be repeated.

4.3.9 Perishable Mode Cooling – Sequence of Operation

NOTE

In Standard Perishable Mode, the evaporator motors run in high speed. In Economy Fan Mode, fan speed is varied.

NOTE

In low temperature ambients, the condenser fan will be cycled by the controller to maintain proper condensing pressure.

- a. With supply air temperature above set point and decreasing, the unit will cooling with the condenser fan motor (CF), compressor motor (CH), evaporator fan motors (EF) energized, and the white COOL light illuminated (see Figure 4.6).

Figure 4.6 Perishable Mode Cooling

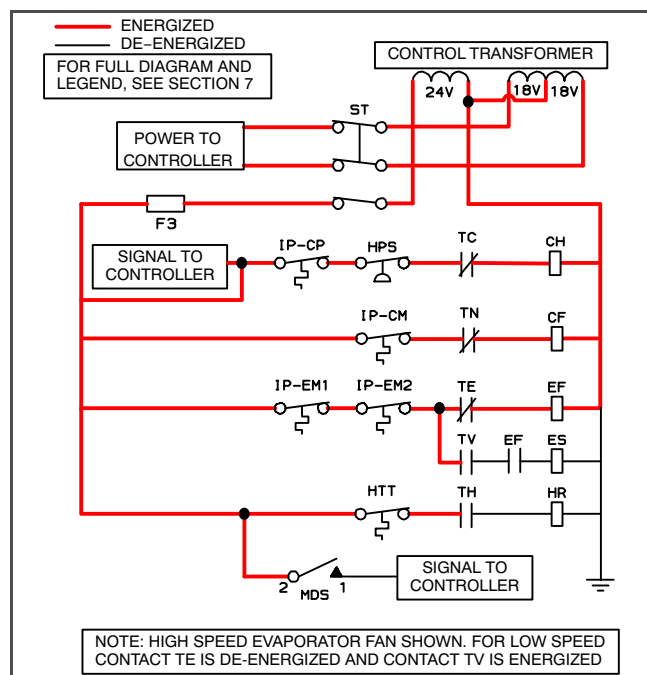

- b. When supply air temperature decreases to a predetermined tolerance above set point (Cd30), the green IN RANGE light is illuminated.
- c. As the air temperature continues to fall, modulating cooling starts as the supply air temperature approaches set point.
- d. The controller continuously monitors supply air temperature. Once the supply air temperature falls below set point and 0% SMV position is reached, the controller periodically records the supply air temperature, set point, and time. A calculation is then performed to determine temperature drift from set point over time. If the calculation determines that cooling is no longer required, contacts TC and TN are opened to de-energize the compressor motor and the condenser fan motor.
- e. The evaporator fan motors continue to run to circulate air throughout the container. The green IN-RANGE light remains illuminated as long as the supply air is within tolerance of set point.
- f. When the supply air temperature increases to 0.2°C (0.36°F) above set point and the three minute off time has elapsed, relays TC and TN are energized to restart the compressor and condenser fan motor. The white COOL light is also illuminated.

4.3.10 Perishable Mode Heating – Sequence of Operation

NOTE

The unit will heat only when in the Perishable Mode, relay TH is electronically locked out when in the Frozen Mode.

- a. If the supply air temperature decreases 0.5°C (0.9°F) below set point, the system enters the heating mode (see [Figure 4.5](#)). The controller closes contacts TH (see [Figure 4.7](#)) to allow power flow through the heat termination thermostat (HTT) to energize the heaters (HR). The orange HEAT light is also illuminated. The evaporator fans continue to run to circulate air throughout the container.
- b. When the supply temperature rises to 0.2°C (0.36°F) below set point, contact TH opens to de-energize the heaters. The HEAT light is also de-energized. The evaporator fans continue to run to circulate air throughout the container.
- c. The safety heater termination thermostat (HTT) is attached to an evaporator coil circuit and will open the heating circuit if overheating occurs.

Figure 4.7 Perishable Mode Heating

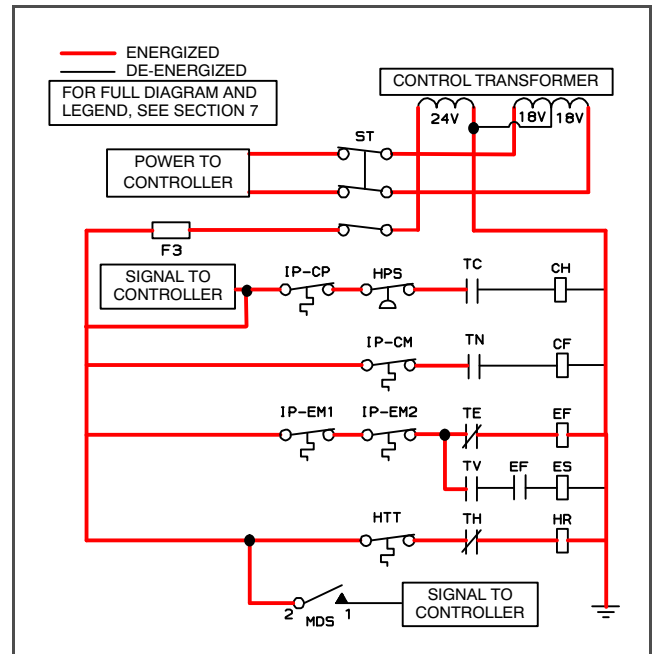

4.3.11 Frozen Mode - Temperature Control

In Frozen Mode, the controller maintains the return air temperature at set point, the yellow RETURN indicator light is illuminated, and the default reading on the display window is the return temperature sensor (RTS) reading.

When the return air temperature enters the in-range temperature tolerance (Cd30), the green IN-RANGE light will energize.

With CnF26 (Heat Lockout Temperature) is set to -10°C, frozen mode is active with set points at or below -10°C (+14°F). With CnF26 set to -5°C, frozen mode is active at or below -5°C (+23°F).

When the system is in Frozen Mode, the highest priority is given to bringing the container down to set point.

When return air temperature is greater than 0.2°C (0.36°F) above the frozen set point and the three minute time delay has been met, the unit will always operate at full capacity with the suction modulation valve open as allowed by current and pressure limiting.

4.3.12 Frozen Steady State

Frozen range cargoes are not sensitive to minor temperature changes. The method of temperature control employed in frozen range takes advantage of this fact to greatly improve the energy efficiency of the unit. Temperature control in frozen range is accomplished by cycling the compressor on and off as the load demand requires.

The unit will operate in the conventional frozen mode when the controller set point is at or below the frozen range and Economy Mode (Cd34) is set to "OFF."

Figure 4.8 Controller Operation - Frozen Mode

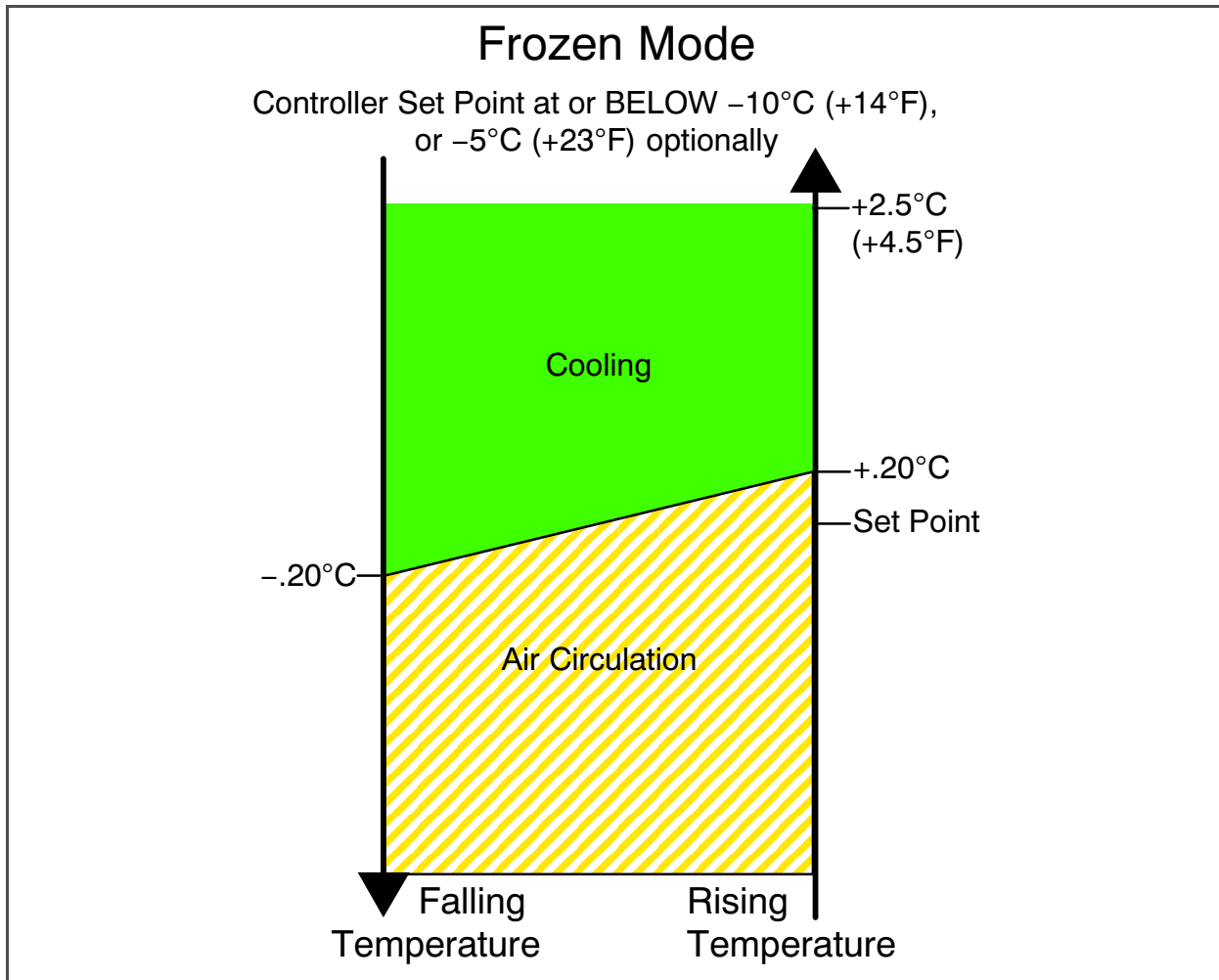

4.3.13 Frozen Idle Mode

When temperature drops to set point minus 0.2°C (0.36°F) and the compressor has run for at least five minutes, the unit will transition to the frozen idle mode. The compressor is turned off and the evaporator fans continue to run to circulate air throughout the container. If temperature rises above set point +0.2°C, (0.36°F) the unit will transition back to the frozen steady state mode.

NOTE

On start up of the unit, SMV will reset to a known open position. This is accomplished by assuming the valve was fully open, driving it fully closed, resetting the percentage open to zero, then opening to a known 21% staging position.

To prevent rapid cycling of the compressor, a three minute compressor off time must be satisfied before the compressor will restart. Under a condition of rapidly changing return air temperature, the time delay may allow the return air temperature to rise slightly above set point temperature before the compressor can restart.

4.3.14 Frozen "Heat" Mode

If the temperature drops 10°C (18°F) below set point, the unit will transition to the frozen "heating" mode. The evaporator fans are brought to high speed, and the heat from the fans is circulated through the container. The unit will transition back to frozen steady state when the temperature rises back to the transition point.

4.3.15 Frozen Economy Mode

In order to activate economy frozen mode operation, a frozen set point temperature must be selected, and Cd34 (Economy Mode) set to "ON." When economy mode is active, the system will perform normal frozen mode operations except that the entire refrigeration system, excluding the controller, will be turned off when the control temperature is less than or equal to the set point -2°C (3.6°F).

After an off-cycle period of 60 minutes, the unit will turn on high speed evaporator fans for three minutes and then check the control temperature. If the control temperature is greater than or equal to the frozen set point +0.2°C (0.36°F), the unit will restart the refrigeration system and continue to cool until the previously mentioned off-cycle temperature criteria are met. If the control temperature is less than the frozen set point +0.2°C (0.36°F), the unit will turn off the evaporator fans and restart another 60 minute off-cycle.

4.3.16 Frozen Mode Cooling – Sequence of Operation

NOTES

1. In the Frozen Mode the evaporator motors run in low speed.
 2. In low temperature ambients, the condenser fan will be cycled by the controller to maintain proper condensing pressure, refer to [Section 4.4.4](#).
- a. When the return air temperature is above set point and decreasing, the unit will be cooling with the condenser fan motor (CF), compressor motor (CH), evaporator fan motors (ES) energized and the white COOL light illuminated (see [Figure 4.9](#)).
 - b. When the return air temperature decreases to a predetermined tolerance above set point, the green INRANGE light is illuminated.
 - c. When the return air temperature decreases to 0.2°C (0.36°F) below set point, contacts TC and TN are opened to de-energize the compressor and condenser fan motors. The white COOL light is also de-energized.
 - d. The evaporator fan motors continue to run in low speed to circulate air throughout the container.
 - e. The green IN-RANGE light remains illuminated as long as the return air is within tolerance of set point.
 - f. When the return air temperature increases to 0.2°C (0.36°F) above set point and the three minute off time has elapsed, relays TC and TN are energized to restart the compressor and condenser fan motors. The white COOL light is also illuminated.

Figure 4.9 Frozen Mode

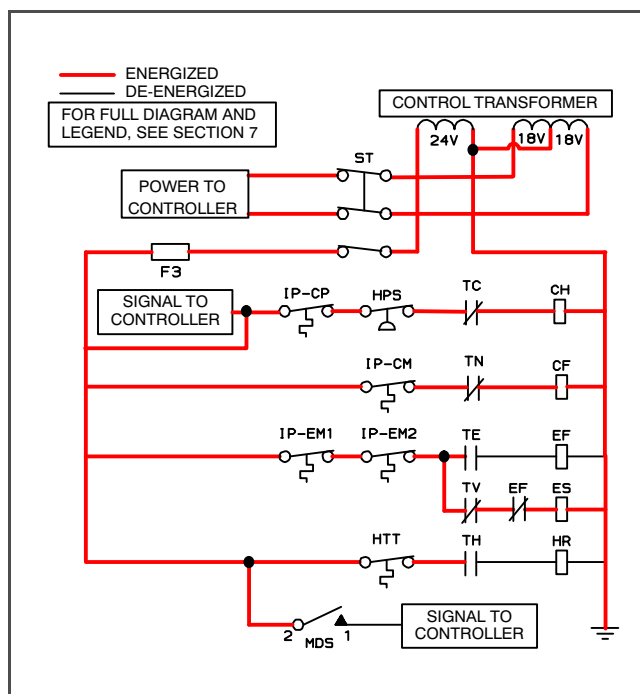

4.3.17 Defrost

Defrost is initiated to remove ice buildup from the evaporator coil which can obstruct air flow and reduce the cooling capacity of the unit. The defrost cycle may consist of up to three distinct operations depending upon the reason for the defrost or model number configuration. The first is de-icing of the coil, the second is defrost due to a probe check cycle and the third is a snap freeze process based on the unit model configuration.

Defrosting the coil consists of removing power to the cooling components (compressor, evaporator fans, and condenser fan), closing the SMV, and turning on the heaters, which are located below the evaporator coil. During normal operation, de-icing will continue until temperatures indicate that the ice on the coil has been removed, proper air flow has been restored, and the unit is ready to control temperature efficiently.

If defrost was initiated by the probe check logic, then a Probe Check is carried out after the completion of the defrost cycle. A Probe Check is initiated only when there is an inaccuracy between the controller temperature sensors. For more information on Probe Check refer to [Section 5.9](#).

Snap Freeze allows the system to cool for a period of time after de-icing, with the evaporator fans turned off and is only carried out if configured by model number. Snap-Freeze allows for the removal of latent de-icing heat from the evaporator coils, and freezes any remaining moisture that might otherwise be blown into the container.

4.3.18 Defrost Operation

Initiation of defrost is dependent on the state of the Defrost Temperature Sensor (DTS). When the (DTS) senses a temperature less than 10°C (50°F) the defrost options become active and the timer is engaged for the initiation of the defrost cycle. The defrost time accumulates when the compressor is running. In the perishable mode this is the same as real time as the compressor in general runs continuously. In frozen mode the actual time necessary to count down to the next defrost will exceed the defrost interval depending on the compressor duty-cycle.

When the defrost mode is in the active state, defrost can be initiated when any one of the following additional conditions become true:

1. Manually: A manual defrost is initiated by pressing the MANUAL DEFROST/INTERVAL key for greater than 5 seconds.
2. Timer: The Defrost Interval Timer reaches the user selectable Interval. The user-selected intervals are (OFF), 3, 6, 9, 12, 24 hours, AUTO, or PuLS; factory default is 3 hours. Refer to code select CD27 (Table 3-5).

- a. Automatic defrost starts with an initial defrost at three hours and then adjusts the interval to the next defrost based on the accumulation of ice on the evaporator coil. Following a start-up or after termination of defrost, the time will not begin counting down until the DTS reading falls below 10°C (50°F). If the reading of DTS rises above termination setting any time during the timer count down, the interval is reset and the countdown starts over. The Auto defrost time is reset to three hours start time after every PTI initiation or trip start interval.
- b. Fan Pulsing Logic is used to help prevent ice formation in the drain gutter and drain cup and ice buildup in supply air channel by using the evaporator fans to blow the warm air onto these areas during unit defrost. When cooling at lower setpoints, evaporator fan pulsing can be used during Defrost/De-ice when the “PuLS” option is selected in the Defrost Interval function select code. When enabled, evaporator fan pulsing will occur based on the unit temperature setpoint and the Evaporator Fan Pulsing Temperature Setting (Cd60). QUEST II also pulses the evaporator fans during Defrost/De-ice within a narrow perishable setpoint range. The logic for each evaporator fan pulsing feature is described below.
- c. After a new Defrost Interval is selected, the previously selected Interval is used until the next defrost termination, the next time the DTS contacts are OPEN, or the next time power to the control is interrupted. If the previous value or the new value is “OFF”, the newly selected value will be used immediately.

- 3. If defrost is initiated due to Probe Check immediately following the defrost cycle the evaporation fans are started and run for eight minutes to stabilize the temperature throughout the container. A probe check comparison is carried out at the end of the eight minute period if any sensor is found out of calibration. At this time it is no longer used for control/reorder purposes.
- 4. Probe Check Logic: The logic determines that a Probe Check is necessary based on temperature values currently reported by the supply and return probes.
- 5. Remote: An Initiate Defrost command is sent via communications.

- 6. Delta T Logic: If the difference between return and supply air temperature (Delta T) becomes too great indicating possible reduced airflow over the evaporator coil caused by ice buildup requiring a defrost.
 - a. In Perishable Pull Down - Delta T increases to greater than 12°C, and 90 minutes of compressor run time have been recorded.
 - b. In Perishable Steady State – A baseline Delta T is recorded following the first defrost cycle after steady state conditions are reached, (the unit is cooling, and the evaporator fans and heaters must remain in a stable state for a period of five minutes). Defrost will be initiated if Delta T increases to greater than 4°C above the baseline, and 90 minutes of compressor run time have been recorded.
 - c. In Frozen Mode - Defrost will be initiated if Delta T increases to greater than 16°C and 90 minutes of compressor run time have been recorded.

NOTICE

When defrost is initiated, the controller closes the SMV, opens contacts TC, TN and TE (or TV) to de-energize the compressor, condenser fan and evaporator fans.

The controller then closes contacts TH to supply power to the heaters. The orange DEFROST light and heat light are illuminated and the COOL light is also de-energized.

Figure 4.10

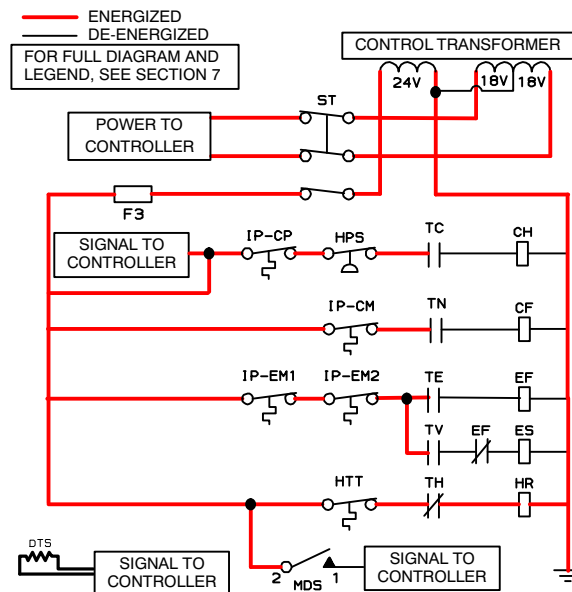

NOTICE

The SMV is independently operated by the microprocessor. Complete schematics and legends are located in [Section 8.1](#).

Defrost will terminate when the DTS reading rises above one of two model number configurable options selection, either an upper setting of 25.6°C (78°F) which is default or lower setting of 18°C (64°F).

When the DTS reading rises to the configured setting, the de-icing operation is terminated.

4.3.19 Defrost Related Settings

IDTS Failure

When the return air temperature falls to 7°C (45°F), the controller ensures that the defrost temperature sensor (DTS) reading has dropped to 10°C or below. If it has not it indicates a failed DTS, a DTS failure alarm is triggered and the defrost mode is operated by the return temperature sensor (RTS). Defrost will terminate after 1 hour.

If the DTS fails to reach its termination setting, the defrost terminates after 2 hours of operation.

Defrost Timer

If CnF23 is configured to “SAv” (save), then the value of the defrost interval timer will be saved at power down and restored at power up. This option prevents short power interruptions from resetting an almost expired defrost interval, and possibly delaying a needed defrost cycle. If the save option is not selected the defrost timer will re-initiate and begin recounting.

If CnF11 is model number configured to OFF the operator will be allowed to choose “OFF” as a defrost interval option.

If CnF64 is configured in the operator will be allowed to choose “PuLS” as a defrost interval option. For units operating with “PuLS” selected, defrost interval is determined by the unit temperature setpoint and the Evaporator Fan Pulsing Temperature Setting (Cd60). When the unit temperature setpoint is equal to or less than the Evaporator Fan Pulsing Temperature Setting, the defrost interval is set to 6 hours. Otherwise, the defrost interval is determined using the Automatic Defrost Interval Determination logic. In either case, “PuLS” remains displayed in this function select code.

If any Auto Pretrip sequence is initiated, Cd27 will be set to 'AUTO' unless CnF49 (OEM Reset) is set to “Custom” AND CnF64 (Evaporator Fan Pulsing Logic) configuration variable is set to IN, in which case Cd27 will be set to “PuLS”.

If defrost does not terminate correctly and temperature reaches the set point of the Heat Termination Thermostat (HTT) 54°C (130°F), the HTT will open to de-ener-

gize the heaters (AL59 & AL60). If the HTT does not open and termination does not occur within two hours, the controller will terminate defrost. AL60 will be activated to inform of a possible DTS failure.

4.4 PROTECTION MODES OF OPERATION

4.4.1 Evaporator Fan Operation

Opening of an evaporator fan internal protector will shut down a unit. (CnF32 set to 2EFO).

4.4.2 Failure Action

Function code Cd29, Failure Action Mode, may be operator set to allow continued operation in the event the control sensors are reading out of range. The factory default is full system shutdown (refer to [Table 4-5](#)).

4.4.3 Generator Protection

Function codes Cd31, Stagger Start Offset Time, and Cd32, System Current Limit, may be operator set to control start-up sequence of multiple units and operating current draw. The factory default allows on demand starting of units and full current draw (refer to [Table 4-5](#)).

4.4.4 Condenser Pressure Control

When configuration variable CnF14 is set to “In,” the condenser pressure control logic is activated to maintain discharge pressures above 130psig in low temperature ambients. The logic turns the condenser fan on or off in accordance with the condenser pressure transducer reading (refer to [Table 4-4](#)) The function is enabled when the following conditions are met:

1. The ambient sensor reading is less than or equal to 27°C (80°F), and
2. Voltage/Frequency ratio is less than or equal to 8.38.

When the above conditions are met, either pressures or timers may dictate a change of state from OFF to ON or ON to OFF. If the condenser fan is OFF, it will be energized if saturated condensing pressure is greater than 200psig OR if the condenser fan has been OFF for a variable time period of up to 60 seconds depending on the ambient temperature. As the ambient temperature increases, the amount of time that the condenser fan is energized will correspondingly increase towards the maximum.

If the condenser fan is ON, it will de-energize only if the saturated condensing pressure is less than 130psig and the condenser fan has been running for a minimum of thirty seconds depending on the ambient temperature.

4.5 QUEST – CCPC

Compressor–Cycle Perishable Cooling (CCPC) is a method of temperature control during steady–state perishable cooling that cycles the compressor on and off according to return air temperature.

To be eligible for steady-state control the unit must first complete a “setpoint pulldown” phase and a “CCPC pulldown” phase:

During setpoint pulldown supply air temperature is controlled according to the unit’s nominal supply air setpoint.

During CCPC pulldown the supply air temperature is lowered somewhat relative to the nominal setpoint. Evaporator fans are forced to operate at high speed.

Steady-state CCPC control maintains the same lowered supply air temperature as was used during CCPC pulldown. The compressor cycles on and off according to return air high and low limits. Depending on the fan mode of operation selected, the evaporator fans may be programmed to run at low speed some or all of the time according to the control logic.

4.6 CONTROLLER ALARMS

Alarm display is an independent controller software function. If an operating parameter is outside of expected range or a component does not return the correct signals back to the controller, an alarm is generated. A listing of the alarms is provided in [Table 4–6](#).

The alarm philosophy balances the protection of the refrigeration unit and that of the refrigerated cargo. The action taken when an error is detected always considers the survival of the cargo. Rechecks are made to confirm that an error actually exists.

Some alarms requiring compressor shutdown have time delays before and after to try to keep the compressor on line. An example is alarm code “LO,” (low main voltage), when a voltage drop of over 25% occurs, an indication is given on the display, but the unit will continue to run.

An alarm is indicated by flashing an alarm code on the display panel, and for some alarms, by the alarm light illuminating.

When an Alarm Occurs:

- a. The red alarm light will illuminate for “20 series” alarms.
- b. If a detectable problem is found to exist, its alarm code will be alternately displayed with the set point on the left display.
- c. The user should scroll through the alarm list to determine what alarms exist or have existed. Alarms must be diagnosed and corrected before the Alarm List can be cleared.

To Display Alarm Codes:

- a. While in the Default Display mode, press the ALARM LIST key. This accesses the Alarm List Display Mode, which displays any alarms archived in the Alarm Queue.
- b. The alarm queue stores up to 16 alarms in the sequence in which they occurred. The user may scroll through the list by depressing an ARROW key.
- c. The left display will show “AL##,” where ## is the alarm number sequentially in the queue.
- d. The right display will show the actual alarm code. “AA##” will display for an active alarm, where “##” is the alarm code. Or “IA##” will display for an inactive alarm.
- e. “END” is displayed to indicate the end of the alarm list if any alarms are active.
- f. “CLEAR” is displayed if all alarms are inactive. The alarm queue may then be cleared by pressing the ENTER key. The alarm list will clear and “----” will be displayed.

NOTE

AL26 is active when all of the sensors are not responding. Check the connector at the back of the controller, if it is loose or unplugged, reconnect it. Then run a pretrip test (P5) to clear AL26.

4.7 PRE-TRIP DIAGNOSTICS

Pre-trip diagnostics is an independent controller function that will suspend normal refrigeration controller activities and provide preprogrammed test routines. The test routines include Auto Mode testing, which automatically performs a pre-programmed sequence of tests or Manual Mode testing, which allows the operator to select and run any of the individual tests.



Pre-trip inspection should not be performed with critical temperature cargoes in the container.



When Pre-Trip key is pressed, dehumidification and bulb mode will be deactivated. At the completion of Pre-Trip activity, dehumidification and bulb mode must be reactivated.

A Pre-trip test may be initiated by use of the keypad or via communication, but when initiated by communication the controller will execute the entire battery of tests (auto mode).

At the end of a pre-trip test, the message “P,” “rSLts” (pretest results) will be displayed. Pressing ENTER will allow the user to see the results for all subtests. The results will be displayed as “PASS” or “FAIL” for all the tests run to completion.

A detailed description of the pre-trip tests and test codes is provided in [Table 4–7](#). Detailed operating instructions are provided in [Section 5.8](#).

4.8 DATACORDER

The Carrier Transicold “DataCORDER” software is integrated into the controller and serves to eliminate the temperature recorder and paper chart. DataCORDER functions may be accessed by keypad selections and viewed on the display module. The unit is also fitted with interrogation connections (see [Figure 4.1](#)). A personal computer with Carrier Transicold DataLINE software may also be used to download data and configure settings.

The resulting file uses a proprietary file format that protects it from potential tampering or altering of data. Therefore, once downloaded, all dcx files shall be considered secured. The DataCORDER consists of:

The DataCORDER consists of:

- Configuration Software
- Operational Software
- Data Storage Memory
- Real Time Clock (with internal battery backup)
- Six Thermistor Inputs
- Interrogation Connections
- Power Supply (battery pack)

The DataCORDER performs the following functions:

- a. Logs data at 15, 30, 60 or 120 minute intervals and stores two years’ of data (based on one hour interval).
- b. Records and displays alarms on the display module.
- c. Records results of Pre-trip testing.
- d. Records DataCORDER and temperature control software generated data and events as follows:
 - Container ID Change
 - Software Upgrades
 - Alarm Activity
 - Battery Low (Battery Pack)
 - Data Retrieval
 - Defrost Start and End
 - Dehumidification Start and End

- Power Loss (with and without battery pack)
- Power Up (with and without battery pack)
- Remote Probe Temperatures in the Container USDA cold treatment and cargo probe recording)
- Return Air Temperature
- Set Point Change
- Supply Air Temperature
- Real Time Clock Battery (Internal) Replacement
- Real-Time Clock Modification
- Trip Start
- ISO Trip Header (When entered via Interrogation program)
- Economy Mode Start and End
- “Auto 1/Auto 2/Auto 3” Pre-trip Start and End
- Bulb Mode Start
- Bulb Mode changes
- Bulb Mode End
- USDA Trip Comment
- Humidification Start and End
- USDA Probe Calibration
- Fresh Air Vent Position

4.8.1 DataCORDER Software

The DataCORDER Software is subdivided into Operational Software, Configuration Software, and the Data Memory.

a. Operational Software (dC Function Codes)

The Operational Software reads and interprets inputs for use by the Configuration Software. The inputs are labeled Function Codes. Controller function codes (see [Table 4–8](#)), allow the operator to examine the current input data or stored data. To access these codes, do the following:

1. Press the ALT. MODE and CODE SELECT keys.
2. Press an arrow key until the left window displays the desired code number. The right window will display the value of this item for five seconds before returning to the normal display mode.
3. If a longer time is desired, press the ENTER key to extend the time to 30 seconds.

b. Configuration Software

The configuration software controls the recording and alarm functions of the DataCORDER. Reprogramming to the factory-installed configuration is achieved via a configuration card. Changes to the software may be made using the DataLINE integration software.

A list of the configuration variables is provided in [Table 4–2](#). Descriptions of DataCORDER operation for each variable setting are provided in the following paragraphs.

4.8.2 Sensor Configuration (dCF02)

Two modes of operation may be configured, the Standard Mode and the Generic Mode.

a. Standard Mode

In the standard mode, the user may configure the DataCORDER to record data using one of seven standard configurations. The seven standard configuration variables, with their descriptions, are listed in [Table 4–3](#).

The six thermistor inputs (supply, return, USDA #1, #2, #3, and cargo probe) and the humidity sensor input will be generated by the DataCORDER. An example of a report using a standard configuration is shown in [Figure 4.11](#).

NOTE

The DataCORDER software uses the supply and return recorder sensors. The temperature control software uses the supply and return temperature sensors.

b. Generic Mode

The generic recording mode allows user selection of the network data points to be recorded. The user may select up to a total of eight data points for recording. A list of the data points available for recording follows. Changing the configuration to generic and selecting which data points to record may be done using the Carrier Transicold Data Retrieval Program.

1. Control mode
2. Control temperature
3. Frequency
4. Humidity
5. Phase A current
6. Phase B current

7. Phase C current
8. Main voltage
9. Suction modulation valve percentage
10. Discrete outputs (See Note)
11. Discrete inputs (See Note)
12. Ambient sensor
13. Compressor suction sensor
14. Compressor discharge sensor
15. Return temperature sensor
16. Supply temperature sensor
17. Defrost temperature sensor
18. Discharge pressure transducer
19. Suction pressure transducer
20. Condenser pressure transducer

4.8.3 Logging Interval (dCF03)

The user may configure four time intervals between data recordings. Data is logged at exact intervals in accordance with the real-time clock. The clock is factory set at Greenwich Mean Time.

4.8.4 Thermistor Format (dCF04)

The user may configure the format in which the thermistor readings are recorded. The low resolution is a 1 byte format and the normal resolution is a 2 byte format. The low resolution requires less memory and records temperature in 0.25°C (0.45°F) increments when in perishable mode or 0.5°C (0.9°F) increments when in the frozen mode. The normal resolution records temperature in 0.01°C (0.02°F) increments for the entire range.

Table 4–2 Data CORDER Configuration Variables

| CONFIGURATION NO. | TITLE | DEFAULT | OPTION |
|-------------------|--|---------|------------------|
| dCF01 | (Future Use) | -- | -- |
| dCF02 | Sensor Configuration | 2 | 2,5,6,9,54,64,94 |
| dCF03 | Logging Interval (Minutes) | 60 | 15,30,60,120 |
| dCF04 | Thermistor Format | Short | Low, Normal |
| dCF05 | Thermistor Sampling Type | A | A,b,C |
| dCF06 | Controlled Atmosphere/Humidity Sampling Type | A | A,b |
| dCF07 | Alarm Configuration USDA Sensor 1 | A | Auto, On, Off |
| dCF08 | Alarm Configuration USDA Sensor 2 | A | Auto, On, Off |
| dCF09 | Alarm Configuration USDA Sensor 3 | A | Auto, On, Off |
| dCF10 | Alarm Configuration Cargo Sensor | A | Auto, On, Off |

Figure 4.11 Standard Configuration Report

ViewData - [Raw Data Report - 1]

File Reports Window

Raw Data Report for ABCU1234567
Aug 22, 2012 to Sept 05, 2012

System Configuration at the Time of Interrogation:
Interrogated On Sept 05, 2012
Extracted by DataLine Rev 2.1

Controller Software: 5154
Controller Serial #: 04163552
Bill of Lading #: 1

Origin: Origin Date:
Destination: Discharge Date:
Comment: DataLine Tool

Probe Calibration Readings: USDA1: 0.0 USDA2: 0.0 USDA3: 0.0 argo: 0.0
Temperature Units: Centigrade

Aug 22, 2012
Setpoint: 1.66, Container :
9 Sensors Logged at 15 Minute Interval

| Sensor | Format | Resolution |
|--------|--------|------------|
|--------|--------|------------|

F1=Help 234567aa.dcx ML3 ABCU1234567 552 08/22/2012 09/05/2012

Start ViewData - [Raw Dat... Microsoft Word - Docme

1:43 PM

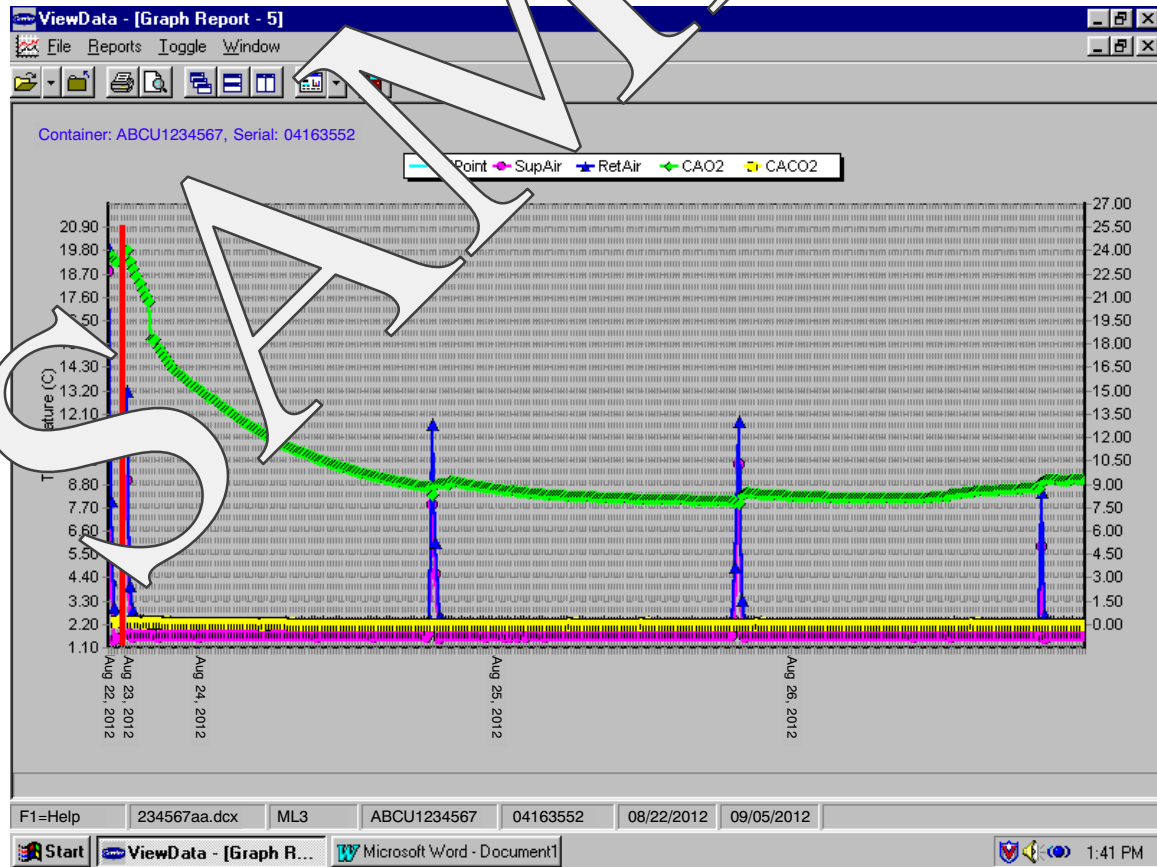

Table 4–3 Data CORDER Standard Configurations

| Standard Config. | Description |
|-----------------------|---|
| 2 sensors (dCF02=2) | 2 thermistor inputs (supply & return) |
| 5 sensors (dCF02=5) | 2 thermistor inputs (supply & return) 3 USDA thermistor inputs |
| 6 sensors (dCF02=6) | 2 thermistor inputs (supply & return) 3 USDA thermistor inputs 1 humidity input |
| 9 sensors (dCF02=9) | Not Applicable |
| 6 sensors (dCF02=54) | 2 thermistor inputs (supply & return) 3 USDA thermistor inputs 1 cargo probe (thermistor input) |
| 7 sensors (dCF02=64) | 2 thermistor inputs (supply & return) 3 USDA thermistor inputs 1 humidity input 1 cargo probe (thermistor input) |
| 10 sensors (dCF02=94) | 2 thermistor inputs (supply & return) 3 USDA thermistor inputs 1 humidity input 1 cargo probe (thermistor input) |

4.8.5 Sampling Type (dCF05 & dCF06)

Three types of data sampling are available –average, snapshot, and USDA. When configured to average, the average of readings taken every minute over the recording period is recorded. When configured to snapshot, the sensor reading at the log interval time is recorded. When USDA is configured, the supply and return temperature readings are averaged and the three USDA probe readings are snapshot.

4.8.6 Alarm Configuration (dCF07 – dCF10)

The USDA and cargo probe alarms may be configured to OFF, ON or AUTO.

If a probe alarm is configured to OFF, then the alarm for this probe is always disabled.

If a probe alarm is configured to ON, then the associated alarm is always enabled.

If the probes are configured to AUTO, they act as a group. This function is designed to assist users who keep their DataCORDER configured for USDA recording, but do not install the probes for every trip. If all the probes are disconnected, no alarms are activated. As soon as one of the probes is installed, then all of the alarms are enabled and the remaining probes that are not installed will give active alarm indications.

The DataCORDER will record the initiation of a pre-trip test (refer to [Section 4.7](#)) and the results of each of the tests included in pre-trip. The data is time-stamped and may be extracted via the Data Retrieval program. Refer to [Table 4–9](#) for a description of the data stored in the DataCORDER for each corresponding pre-trip test.

4.8.7 DataCORDER Power-Up

The DataCORDER may be powered up in any one of four ways:

1. *Normal AC power:* The DataCORDER is powered up when the unit is turned on via the stop-start switch.
2. *Controller DC battery pack power:* If a battery pack is installed, the DataCORDER will power up for communication when an interrogation cable is plugged into an interrogation receptacle.
3. *External DC battery pack power:* A 12–volt battery pack may also be plugged into the back of the interrogation cable, which is then plugged into an interrogation port. No controller battery pack is required with this method.
4. *Real-time Clock demand:* If the DataCORDER is equipped with a charged battery pack and AC power is not present, the DataCORDER will power up when the real-time clock indicates that a data recording should take place. When the DataCORDER is finished recording, it will power down.

During DataCORDER power-up, while using battery-pack power, the controller will perform a hardware voltage check on the battery. If the hardware check passes, the Controller will energize and perform a software battery voltage check before DataCORDER logging. If either test fails, the real-time clock battery power-up will be disabled until the next AC power cycle. Further DataCORDER temperature logging will be prohibited until that time.

An alarm will be generated when the battery voltage transitions from good to bad indicating that the battery pack needs recharging. If the alarm condition persists for more than 24 hours on continuous AC power, the battery pack needs replacement.

4.8.8 Pre-trip Data Recording

The DataCORDER will record the initiation of a Pre-trip test (refer to [Section 4.7](#)) and the results of each of the tests included in pre-trip. The data is time-stamped and may be extracted via the Data Retrieval program. Refer to [Table 4–9](#) for a description of the data stored in the DataCORDER for each corresponding pre-trip test.

4.8.9 DataCORDER Communications

Data retrieval from the DataCORDER can be accomplished by using the DataLINE, DataBANK Card, or a communications interface module.

NOTE

A DataLINE or a communications interface module display of Communication Failed is caused by faulty data transfer between the datacorder and the data retrieval device. Common causes include:

1. Bad cable or connection between DataCORDER and data retrieval device.
2. PC communication port(s) unavailable or mis-assigned.

Communication identification for the models covered herein may be obtained on the Container Products Group Information Center by authorized Carrier Transcold Service Centers.

a. DataLine

The DataLINE software for a personal computer is supplied on both floppy disks and CD. This software allows interrogation, configuration variable assignment, screen view of the data, hard copy report generation, cold treatment probe calibration, and file management. Refer to Data Retrieval manual 62-10629 for a more detailed explanation of the DataLINE interrogation software. The DataLine manual may be found on the Internet at www.container.carrier.com.

c. DataBANK Card

The DataBANK™ card is a PCMCIA card that interfaces with the controller through the programming slot and can download data at a fast rate. Files downloaded to DataBANK card files are accessible through an Omni PC Card Drive. The files can then be viewed using the DataLINE software.

b. Communications Interface Module

The communications interface module is a slave module which allows communication with a master central monitoring station. The module will respond to communication and return information over the main power line. With a remote monitoring unit installed, all functions and selectable features that are accessible at the unit may be performed at the master station. Retrieval of all DataCORDER reports may also be performed. Refer to the master system technical manual for further information.

4.8.10 USDA Cold Treatment

Sustained cold temperature has been employed as an effective post harvest method for the control of Mediterranean and certain other tropical fruit flies. Exposing infested fruit to temperatures of 2.2°C (36°F) or below for specific periods results in the mortality of the various stages of this group of insects.

In response to the demand to replace fumigation with this environmentally sound process, Carrier has integrated Cold Treatment capability into its microprocessor system. These units have the ability to maintain supply air temperature within one-quarter degree Celsius of setpoint and record minute changes in product temperature within the DataCORDER memory, thus meeting USDA criteria. Information on USDA is provided in the following subparagraphs

a. USDA Recording

A special type of recording is used for USDA cold treatment purposes. Cold treatment recording requires three remote temperature probes be placed at prescribed locations in the cargo. Provision is made to connect these probes to the DataCORDER via receptacles located at the rear left-hand side of the unit. Four or five receptacles are provided. The four three-pin receptacles are for the probes and fifth, five-pin, receptacle is the rear connection for the Interrogator. The probe receptacles are sized to accept plugs with tricam coupling locking devices. A label on the back panel of the unit shows which receptacle is used for each probe.

The standard DataCORDER report displays the supply and return air temperatures. The cold treatment report displays USDA #1, #2, #3, and the supply and return air temperatures. Cold treatment recording is backed up by a battery so recording can continue if AC power is lost.

b. USDA/ Message Trip Comment

A special feature is incorporated which allows the user to enter a USDA (or other) message at the head of a data report. The maximum message length is 78 characters. Only one message will be recorded per day.

4.8.11 USDA Cold Treatment Procedure

The following is a summary of the steps required to initiate a USDA Cold Treatment:

- a. Calibrate the three USDA probes by ice bathing the probes and performing the calibration function with the DataLINE. This calibration procedure determines the probe offsets and stores them in the controller for use in generating the cold treatment report. Refer to the Data Retrieval manual 62-10629 for more details.
- b. Pre-cool the container to the treatment temperature or below.
- c. Install the DataCORDER module battery pack (if not already installed).
- d. Place the three probes. The probes are placed into the pulp of the fruit (at the locations defined in the following table) as the product is loaded.

| | |
|----------|--|
| Sensor 1 | Place in pulp of the product located next to the return air intake. |
| Sensor 2 | Place in pulp of the product five feet from the end of the load for 40-foot containers, or three feet from the end of the load for 20-foot containers. This probe should be placed in a center carton at one-half the height of the load. |
| Sensor 3 | Place in pulp of product five feet from the end of the load for 40-foot containers or three feet from the end of the load for 20-foot containers. This probe should be placed in a carton at a side wall at one-half the height of the load. |

- e. To initiate USDA recording, connect the personal computer and perform the configuration as follows, using the DataLINE software:
 1. Enter ISO header information.
 2. Enter a trip comment if desired.
 3. Configure the DataCORDER for five probes (s, r, P1, P2, P3) (dcf02=5).
 4. Configure the logging interval for one hour.
 5. Set the sensor configuration to "USDA".
 6. Configure for two byte memory storage format (dcf04=LONG).
 7. Perform a "trip start."

4.8.12 DataCORDER Alarms

Alarm display is an independent DataCORDER function. If an operating parameter is outside of the expected range or a component does not return the correct signals back to the DataCORDER an alarm is generated. The DataCORDER contains a buffer of up to eight alarms. A listing of the DataCORDER alarms is provided in [Table 4-10](#). Refer to [Section 4.8.6](#) for configuration information.

To display alarm codes:

- a. While in the Default Display mode, press the ALT. MODE & ALARM LIST keys. This accesses the DataCORDER Alarm List Display Mode, which displays any alarms stored in the Alarm Queue.
- b. To scroll to the end of the alarm list, press the UP ARROW. Depressing the DOWN ARROW key will scroll the list backward.
- c. The left display will show "AL#" where # is the alarms number in the queue. The right display will show "AA##," if the alarm is active, where ## is the alarm number. "IA##," will show if the alarm is inactive
- d. "END" is displayed to indicate the end of the alarm list if any alarms are active. "CLEAR" is displayed if all the alarms in the list are inactive.
- e. If no alarms are active, the Alarm Queue may be cleared. The exception to this rule is the DataCORDER Alarm Queue Full alarm (AL91), which does not have to be inactive in order to clear the alarm list. To clear the alarm list:
 1. Press the ALT. MODE & ALARM LIST keys.
 2. Press the UP/DOWN ARROW key until "CLEAR" is displayed.

3. Press the ENTER key. The alarm list will clear and "-----" will be displayed.
4. Press the ALARM LIST key. "AL" will show on the left display and "-----" on the right display when there are no alarms in the list.
5. Upon clearing of the Alarm Queue, the Alarm light will be turned off.

4.8.13 ISO Trip Header

DataLINE provides the user with an interface to view/modify current settings of the ISO trip header through the ISO Trip Header screen.

The ISO Trip Header screen is displayed when the user clicks on the "ISO Trip Header" button in the "Trip Functions" Group Box on the System Tools screen.

F9 function - Provides the user with a shortcut for manually triggering the refresh operation. Before sending modified parameter values, the user must ensure that a successful connection is established with the controller.

If the connection is established with the DataCORDER, the current contents of the ISO Trip Header from the DataCORDER will be displayed in each field. If the connection is not established with the DataCORDER, all fields on the screen will be displayed as "Xs." If at any time during the display of the ISO Trip Header screen the connection is not established or is lost, the user is alerted to the status of the connection.

After modifying the values and ensuring a successful connection has been made with the DataCORDER, click on the "Send" button to send the modified parameter values.

The maximum allowed length of the ISO Trip Header is 128 characters. If the user tries to refresh the screen or close the utility without sending the changes made on the screen to the DataCORDER, the user is alerted with a message.

4.9 CONTROLLER CONFIGURATION VARIABLES

Table 4–4 Controller Configuration Variables

| CONFIGURATION NUMBER | TITLE | DEFAULT | OPTION |
|----------------------|-------------------------------------|----------------|------------------------------|
| CnF01 | Bypass Valve Enable | In | 0-in, 1-out |
| CnF02 | Evaporator Fan Speed | dS (Dual) | 0-single, 1-dual |
| CnF03 | Control Sensors | FOUr (quad) | 0-duAL, 1-quad |
| CnF04 | Dehumidification Mode | On | 0-on, 1-off |
| CnF07 | Unit Selection, 20FT/ 40FT/45FT | 40ft | 0-40ft, 1-20ft, 2- 45ft |
| CnF08 | Single Phase/Three Phase Motor | 1Ph | 0-1phe, 1-3phe |
| CnF10 | Two Speed Compressor Logic | Out (Single) | 0-single, 1-dual |
| CnF11 | Defrost Off Selection | noOFF | 0-noOFF, 1-OFF |
| CnF12 | TXV/Solenoid Quench Valve | Out (TXV) | 0-quench, 1-TXV |
| CnF13 | Unloader | Out | 0-in, 1-out |
| CnF14 | Condenser Pressure Control (CPC) | In | 0-in, 1-out |
| CnF15 | Discharge Temperature Sensor | Out | 0-in, 1-out |
| CnF16 | DataCORDER Present | On (Yes) | 0-off, 1-on |
| CnF17 | Discharge Pressure Sensor | Out (No) | 0-out (No), 1-in (Yes) |
| CnF18 | Heater | Old (Low Watt) | 0-old, 1-new (High Watt) |
| CnF19 | Controlled Atmosphere | Out (No) | 0-out, 1-in (Yes) |
| CnF20 | Suction Pressure Sensor | Out (No) | 0-out, 1-in (Yes) |
| CnF21 | Autotransformer | Out | 0-out, 1-in |
| CnF22 | Economy Mode Option | OFF | 0-off, 1-full, 2-std, 3-cust |
| CnF23 | Defrost Interval Timer Save Option | noSAv | 0-no_sav, 1-sav |
| CnF24 | Enable Long PreTrip Test Series | Auto1 | 0-auto1, 1-auto2, 3-aAuto3 |
| CnF25 | Enable PreTrip Data Recording | rSLtS | 0-rSLts, 1-dAtA |
| CnF26 | Heat Lockout Change Option | Set to 10°C | 0= 10°C, 1= 5°C |
| CnF27 | Suction Temperature Display Option | Out | 0-out, 1-in |
| CnF28 | Enable Bulb Mode Option | NOr | 0-normal, 1-bulb |
| CnF29 | Enable Arctic Mode | Out | 0-out, 1-in |
| CnF30 | Compressor Size | 41cfm | 0-41cfm, 1-37cfm |
| CnF31 | Probe Check Option | SPEC | 0-Std, 1-Special |
| CnF32 | Enable Single Evaporator Fan Option | 2EF0 (dual) | 0-dual, 1-single_enable |
| CnF33 | Enable Snap Freeze Option | OFF | 0-off, 1-snap |
| CnF34 | Temperature Unit Display | bOth (C&F) | 0-enable both, 1-F, 2-C |
| CnF35 | Enable Humidification Mode | 0-OFF | 1-on |
| CnF36 | SMV Type | PWM | 0-PWM, 1-Spor, 2-Alco |
| CnF37 | Electronic Temperature Recorder | rEtUR | 0-return, 1-supp, 2-both |
| CnF38 | Quench Bypass Valve | 0-Out | 1-in |

Table continued on next page...

Table 4–4 Controller Configuration Variables

| CONFIGURATION NUMBER | TITLE | DEFAULT | OPTION |
|-----------------------------|---------------------------------------|----------------|-----------------------|
| CnF39 | Expanded Current Limit Range | 0-Out | 1-in |
| CnF40 | Demand Defrost | 0-Out | 1-in |
| CnF41 | Lower DTT Setting | 0-Out | 1-in |
| CnF42 | Enable Auto Pretrip Start | 0-Out | 1-in |
| CnF43 | Pulldown Defrost | 0-Out | 1-in |
| CnF44 | Autoslide Enabled | 0-Out | 1-Lo, 2-Up |
| CnF45 | Low Humidity Enabled | 0-Out | 1-in |
| CnF47 | Fresh Air Vent Position Sensor | 0-Out | 1-up, 2-low, 3-cust |
| CnF48 | CFS / WPS Override | 0-Out | 1-in |
| CnF49 | OEM Reset Option | 0-Off | 1-std, 2-spec, 3-cust |
| CnF50 | Enhanced Bulb Mode Selection | 0-Out | 1-in |
| CnF51 | Timed Defrost Disable | 0-Out | 1-in |
| CnF54 | Remote Evaporator | 0-Out | 1-in |
| CnF60 | Compressor-Cycle Perishable Cooling | 0-Out | 1-in |
| CnF61 | ACT ASC Control Enable | 0-Out | 1-in |
| CnF62 | Extended Temperature Control Enable | 0-Out | 1-in |
| CnF63 | CCPC Pre-trip/Tripstart Default State | 0-On | 1-off |
| CnF64 | Evaporator Fan Pulsing Logic Enable | 0-In | 1-out |
| CnF66 | High Speed Evaporator Fan Option | 0-off | 1-on |
| CnF67 | Air Heaters | 0-out | 1-in |
| CnF68 | Enable Default Pulsing Temperature | 0-out | 1-in |

Note: Configuration numbers not listed are not used in this application. These items may appear when loading configuration software to the controller but changes will not be recognized by the controller programming.

4.10 CONTROLLER FUNCTION CODES

Table 4–5 Controller Function Codes

| Code No. | TITLE | DESCRIPTION |
|---|--|--|
| Note: If the function is not applicable, the display will read “-----” | | |
| Display Only Functions – Cd01 through Cd26 are display only functions. | | |
| Cd01 | Suction Modulation Valve (SMV) Opening (%) | Displays the SMV percent open. The right display reads 100% when the valve is fully open and 0% when the valve is fully closed. The valve will usually be at 21% on start up of the unit except in very high ambient temperatures. |
| Cd02 | Quench Valve State | Displays the state of the solenoid quench valve, open or closed. |
| Cd03 | Suction Solenoid Valve State | Displays the state of the suction solenoid valve, open or closed. |
| Cd04 | Line Current, Phase A | The current sensor measures current on two legs. The third unmeasured leg is calculated based on a current algorithm. The current measured is used for control and diagnostic purposes. For control processing, the highest of the Phase A and B current values is used for current limiting purposes. For diagnostic processing, the current draws are used to monitor component energization. Whenever a heater or a motor is turned ON or OFF, the current draw increase/reduction for that activity is measured. The current draw is then tested to determine if it falls within the expected range of values for the component. Failure of this test will result in a pretrip failure or a control alarm indication. |
| Cd05 | Line Current, Phase B | |
| Cd06 | Line Current, Phase C | |
| Cd07 | Main Power Voltage | The main supply voltage is displayed. |
| Cd08 | Main Power Frequency | The value of the main power frequency is displayed in Hertz. The frequency displayed will be halved if either fuse F1 or F2 is bad (see alarm code AL21). |
| Cd09 | Ambient Air Temperature | The Ambient Temperature Sensor reading is displayed. |
| Cd10 | Compressor Suction Temperature | The Compressor Suction Temperature Sensor reading is displayed. |
| Cd11 | Compressor Discharge Temperature | The Compressor Discharge Temperature Sensor reading is displayed. |
| Cd12 | Compressor Suction Port Pressure | The Compressor Suction Pressure Transducer reading is displayed. |
| Cd13 | Condenser Pressure Control (CPC) Sensor | The Condenser Pressure Control Sensor reading is displayed. |
| Cd14 | Compressor Discharge Pressure | The Compressor Discharge Pressure Transducer reading is displayed. |
| Cd15 | Unloader Valve (On-Off) | Not used in this application |
| Cd16 | Compressor Motor Hour Meter / Switch On Time | Records total hours of compressor run time. Total hours are recorded in increments of 10 hours (i.e., 3000 hours is displayed as 300). / Press 'Enter' to display Start Switch 'ON' time. |
| Cd17 | Relative Humidity (%) | Humidity sensor reading is displayed. This code displays the relative humidity, as a percent value. |
| Cd18 | Software Revision # | The software revision number is displayed. |

Table 4–5 Controller Function Codes

| Code No. | TITLE | DESCRIPTION |
|-----------------|---|--|
| Cd19 | Battery Check | This code checks the Controller/DataCORDER battery pack. While the test is running, “btest” will flash on the right display, followed by the result. PASS will be displayed for battery voltages greater than 7.0 volts. FAIL will be displayed for battery voltages between 4.5 and 7.0 volts, and ---- will be displayed for battery voltages less than 4.5 volts. After the result is displayed for four seconds, “btest” will again be displayed, and the user may continue to scroll through the various codes. |
| Cd20 | Config/Model # | This code indicates the dash number of the model for which the Controller is configured (i.e., if the unit is a 69NT40541100, the display will show 41100). To display controller configuration database information, press ENTER. Values in CFYYM-MDD format are displayed if the controller was configured with a configuration card or with a valid OEM serial port configuration update; YYMMDD represents the publication date of the model configuration database. |
| Cd21 | ML3 - Humidity Water Pump/Air Pump Status | This code displays the status of the humidity water pump (----, On, or OFF). If not configured, the mode is permanently deactivated and will display ----. |
| Cd22 | Compressor State | The status of the compressor is displayed (high, low or off). |
| Cd23 | Evaporator Fan State | Displays the current evaporator fan state (high, low or off). |
| Cd24 | Controlled Atmosphere State | Displays the controlled atmosphere state (----, On or Off). |
| Cd25 | Time Remaining Until Defrost | This code displays the time remaining until the unit goes into defrost (in tenths of an hour). This value is based on the actual accumulated compressor running time. |
| Cd26 | Defrost Temperature Sensor Reading | Defrost Temperature Sensor (DTS) reading is displayed. |

Table 4–5 Controller Function Codes

| Code No. | TITLE | DESCRIPTION |
|---|--|---|
| Configurable Functions | | |
| Configurable Functions – Cd27 through Cd37 are user-selectable functions. The operator can change the value of these functions to meet the operational needs of the container. | | |
| Cd27 | Defrost Interval (Hours or Automatic) | <p>There are two modes for defrost initiation, either user-selected timed intervals or automatic control. The user-selected values are (OFF), 3, 6, 9, 12, 24 hours, AUTO, or PuLS. Factory default is 3 hours.</p> <p>Automatic defrost starts with an initial defrost at three hours and then adjusts the interval to the next defrost based on the accumulation of ice on the evaporator coil. Following a startup or after termination of a defrost, the time will not begin counting down until the defrost temperature sensor (DTS) reading falls below set point. If the reading of DTS rises above set point any time during the timer count down, the interval is reset and the countdown begins over.</p> <p>If the DTS fails, alarm code AL60 is activated and control switches over to the return temperature sensor. The controller will act in the same manner as with the DTS except the return temperature sensor reading will be used.</p> <p>If CnF23 is configured to SAv (save), then the value of the defrost interval timer will be saved at power down and restored at power up. This option prevents short power interruptions from resetting an almost expired defrost interval, and possibly delaying a needed defrost cycle.</p> <p style="text-align: center;">NOTE</p> <p style="text-align: center;">The defrost interval timer counts only during compressor run time.</p> <p>Configuration variable (CnF11) determines whether the operator will be allowed to chose OFF as a defrost interval option.</p> <p>Configuration variable (CnF64) determines whether the operator will be allowed to choose PuLS as a defrost interval option. For units operating with PuLS selected, defrost interval is determined by the unit temperature setpoint and the Evaporator Fan Pulsing Temperature Setting (Cd60). When the unit temperature setpoint is equal to or less than the Evaporator Fan Pulsing Temperature Setting, the defrost interval is set to 6 hours. Otherwise, the defrost interval is determined using the Automatic Defrost Interval Determination logic. In either case, PuLS remains displayed in this function select code.</p> <p>After a new Defrost Interval is selected, the previously selected Interval is used until the next defrost termination, the next time the DTT contacts are OPEN, or the next time power to the control is interrupted. If the previous value or the new value is OFF, the newly selected value will be used immediately.</p> <p>If any Auto Pretrip sequence is initiated, Cd27 will be set to 'AUTO' unless CnF49 (OEM Reset) is set to Custom AND CnF64 (Evaporator Fan Pulsing Logic) con figuration variable is set to IN, in which case Cd27 will be set to PuLS.</p> |
| Cd28 | Temperature Units (Degrees C or Degrees F) | <p>This code determines the temperature units (°C or °F) which will be used for all temperature displays. The user selects °C or °F by selecting function code Cd28 and pushing the ENTER key. The factory default value is Celsius units. This function code will display ----- if CnF34 is set to °F.</p> |
| Cd29 | Failure Action Mode | <p>This is the desired action to be taken if an alarm occurs that severely limits the capability of the control system. Depending upon what alarm has occurred, the actual action taken may not be the same as the desired failure action.</p> <p>The user selects one of four possible actions as follows:</p> <ul style="list-style-type: none"> A - Full Cooling (stepper motor SMV at maximum allowed opening) B - Partial Cooling (stepper motor SMV 11% open) C - Evaporator Fan Only D - Full System Shutdown - Factory Default |

Table 4–5 Controller Function Codes

| Code No. | TITLE | DESCRIPTION |
|----------|-------------------------------------|---|
| Cd30 | In-Range Tolerance | <p>The in-range tolerance will determine the band of temperatures around the set point which will be designated as in-range.</p> <p>For normal temperature control, control temperature is considered in range if it is within setpoint In-Range Tolerance. There are four possible values:</p> <p>1 = +/- 0.5°C (+/0.9°F) 2 = +/- 1.0°C (+/1.8°F) 3 = +/- 1.5°C (+/2.7°F) 4 = +/- 2.0°C (+/3.6°F) - Factory Default</p> <p>If the control temperature is in-range, the INRANGE light will be illuminated.</p> <p>In-Range tolerance shall be set to +/- 2.0°C upon activation of dehumidification or bulb mode (Cd33, Cd35, Cd48).</p> <p>When CCPC is actively controlling, IN-RANGE TOLERANCE is not considered.</p> <p>----- will be displayed whenever Dehumidification or Bulb mode is enabled or when CCPC with six hour re-activation is actively controlling.</p> <p>----- will be displayed whenever Frozen Economy Mode is operating.</p> |
| Cd31 | Stagger Start Offset Time (Seconds) | <p>The stagger start offset time is the amount of time that the unit will delay at startup, thus allowing multiple units to stagger their control initiation when all units are powered up together. The eight possible offset values are:</p> <p>0 (Factory Default), 3, 6, 9, 12, 15, 18 or 21 seconds</p> |
| Cd32 | System Current Limit (Amperes) | <p>The current limit is the maximum current draw allowed on any phase at any time. Limiting the unit's current reduces the load on the main power supply. This is accomplished by reducing the SMV position until current draw is reduced to the set point. When desirable, the limit can be lowered; however, capacity is also reduced. The five values for 460VAC operation are 15, 17, 19, 21 (Factory Default), 23.</p> |
| Cd33 | Humidity Setpoint | <p>This is the value in percent to which the system will dehumidify or humidify. There are configuration variables that determine whether dehumidification/humidification capabilities are installed. In the test mode, the setpoint will be temporarily set to 1%, allowing the test of dehumidification. After 5 minutes, the normal setpoint is restored. If unit is configured for HUMIDIFICATION MODE then selection of a setpoint greater than 75% will activate humidification, and a setpoint less than or equal to 75% will activate dehumidification. If the unit is configured for dehumidification only, then the entire setpoint range will apply to dehumidification. If Pretrip is initiated, this value will be set to OFF automatically.</p> <p>(Replaced by Cd48 if CnF50, Enhanced Bulb Mode, is active.)</p> |
| Cd34 | Economy Mode | <p>The current state of the economy mode option, -----, On, or Off. CnF22 determines whether economy mode offered. Economy mode is a user selectable mode of operation provided for power saving purposes.</p> |
| Cd35 | Bulb Mode | <p>The current state of the bulb mode option, -----, nOr, or bULb.</p> <p>(Replaced by Cd48 if CnF50, Enhanced Bulb Mode, is active.)</p> <p>Bulb mode is an extension of dehumidification control (Cd33). If dehumidification (CnF04) is set to Off, Cd35 will display Nor and the user will be unable to change it. CnF28 determines whether the bulb mode selection is offered.</p> <p>After a dehumidification set point has been selected and entered for code Cd33, the user may then change Cd35 to bulb. After Bulb Mode has been selected and entered, the user may then utilize function codes Cd36 and Cd37 to make the desired changes.</p> |

Table 4–5 Controller Function Codes

| Code No. | TITLE | DESCRIPTION |
|---|-------------------------------------|--|
| Cd36 | Evaporator Fan Speed Select | <p>This is the desired evaporator fan speed for use during the bulb Dehumidification and Humidification mode option. (Replaced by Cd48 if CnF50, Enhanced Bulb Mode, is active.)</p> <p>This code is enabled only if in the dehumidification mode (Cd33) and bulb mode (Cd35) has been set to bulb. If these conditions are not met, alt will be displayed (indicating that the evaporator fans will alternate their speed) and the display cannot be changed.</p> <p>If a dehumidification set point has been selected along with bulb mode then alt may be selected for alternating speed, Lo for low speed evaporator fan only, or Hi for high speed evaporator fan only.</p> <p>If a setting other than alt has been selected and bulb mode is deactivated in any manner, then selection reverts back to alt.</p> |
| Cd37 | Variable DTT Setting (Bulb Mode) | <p>This is the Variable Defrost Termination Thermostat (DTT) setting to be used with the optional bulb mode functionality. This item is only displayed if the bulb mode option is configured on. (Replaced by Cd48 if CnF50, Enhanced Bulb Mode, is active.)</p> |
| Display Only Functions - Cd38 through Cd40 are display only functions. | | |
| Cd38 | Secondary Supply Temperature Sensor | Code Cd38 will display the current supply recorder sensor (SRS) reading for units configured for four probes. If the unit is configured with a DataCORDER, Cd38 will display -----. If the DataCORDER suffers a failure (AL55), Cd38 will display the supply recorder sensor reading. |
| Cd39 | Secondary Return Temperature Sensor | Code Cd39 will display the current return recorder sensor (RRS) reading for units configured for four probes. If the unit is configured with a DataCORDER, Cd39 will display -----. If the DataCORDER suffers a failure (AL55), Cd39 will display the return recorder sensor reading. |
| Cd40 | Container Identification Number | <p>If a valid container id exists, the default display for cd40 will be cd40_XXXXXX where XXXXX is the 5th character through the 9th character of the container id. Pressing the Enter key on cd40 will display id_YYYYYYYY where YYYYYYYY is the 5th character to the 11th character of the container id.</p> <p>If no valid container id exists or the container id is blank, the default display will have cd40 on the left display and the right display will alternate between _nEEd and ___id. Pressing the enter key while on cd40 in the state will prompt the Set Id Interface.</p> <p>On start up if the container id is not valid, cd40 be brought up on the display for the first minute of power up. This can be left by either entering a container id or leaving the code select normally.</p> <p>Code Cd40 is configured at commissioning to read a valid container identification number. The reading will not display alpha characters; only the numeric portion of the number will display.</p> |
| Service Function - Cd41 is used for troubleshooting. | | |
| Cd41 | Valve Override | This code allows manual positioning of the SMV. Refer to paragraph 6.18 for operating instructions. |

Table 4–5 Controller Function Codes

| Code No. | TITLE | DESCRIPTION |
|---|---|--|
| Configurable Functions - Cd43 is a user-selectable function. The operator can change the value of this function to meet the operational needs of the container. | | |
| Cd43 | AutoFresh Mode | <p>Cd43 is a user selectable mode of operation that allows opening and closing of a mechanical air vent door via a stepper motor. Selection modes are as follows: OFF - Air makeup vent will remain closed. USER - Allows for manual selection of the setting. DELAY -The opening of the door is based on selected time, return temperature and flow rate (percent opened). gASLM - The opening is based percent open and CO₂ and O₂ selectable limits (LM). This selection is only active if the unit has a CO₂ sensor. TEST / CAL (CO₂ sensor option units only) - The door will fully open and close to allow the user to inspect its operation. If CAL is selected, the controller will zero calibrate the CO₂ sensor input. If the unit is not configured with AutoFresh, the CD43 will display ----</p> |
| Display Only Function - Cd44 is a display only function. | | |
| Cd44 | eAutoFresh Values / CO ₂ Sensor Status | <p>Code Cd44 displays the eAutoFresh CO₂ and O₂ values (CO₂ and O₂) and CO₂ and O₂ limits (CO₂ LIM and O₂ LIM), respectively. This function code will be dashed out if not configured for eAutofresh. This function code will be dashed if CO₂ sensor is not detected, and a sensor is not expected (didn't have one previously). This function code will display ChECK if a CO₂ sensor has not been auto-detected at the most recent power-up and was detected at a previous power-up. If ChECK is displayed and the ENTER key is pressed, SEnSr is displayed with the choices of YES and no: "YES" sensor should be remembered as detected (present) "no" sensor should not be remembered as being detected (not present)</p> |
| Configurable Functions - Cd45 through Cd48 are user-selectable functions. The operator can change the value of these functions to meet the operational needs of the container. | | |
| Cd45 | Vent Position Sensor (VPS) Position | <p>Values: 0 to 240 for UPPER / 0 to 225 for LOWER This function code will be dashed out if not configured for VPS. When configured for VPS, Cd45 displays the current vent position in units of 5 CMH (units displayed as CM) or CFM (units displayed as CF) depending on the selection of Cd46 (Airflow display units), Cd28 (Metric/Imperial) or the pressing of the deg C/F key. Cd45 will display whenever the control detects movement via the sensor unless AL50 is active. Cd45 will display for 30 seconds, then time out and return to the normal display mode.</p> |
| Cd46 | Airflow Display Units | <p>Selects the airflow units to be displayed by Cd45 if configured for Vent Position Sensor or displayed by USER/FLO under Cd43 if configured for Autoslide. CF = Cubic Feet per Minute CM = Cubic Meters per Hour bOth = Displays CF or CM depending on the setting of Cd28 (Metric/Imperial) or the pressing of the degree C/F key.</p> |
| Cd47 | Variable Economy Temperature Setting | <p>Used when Economy Mode (CnF22) is set to 3-cust. Display will show when the unit is not configured for Economy Mode. When the unit has a perishable setpoint and Economy Mode is active, at the start of each cooling or heating cycle, high speed evaporator fans will run for 3 minutes. After three minutes, the evaporator fans will be switched to low speed any time that the supply temperature is within +/- 0.25°C of the setpoint and the return temperature is less than or equal to the supply temperature + the user selected Cd47 (values are 0.5 °C - 4.0° C, default is 3.0 °C).</p> |

Table 4–5 Controller Function Codes

| Code No. | TITLE | DESCRIPTION |
|---|--|--|
| Cd48 | Dehumidification / Bulb Cargo Mode Parameter Selection | <p>Initially Cd48 will display current dehumidification-mode; bUIb - bulb cargo mode, dEhUM - normal dehumidification, or OFF - off. This display is steady.</p> <p>Pressing ENTER key will take the interface down into a hierarchy of parameter selection menus (mode, setpoint, evaporator speed, DTT setting). Pressing ENTER key in any parameter selection menu commits to selection of the currently displayed parameter and causes the interface to descend into the next parameter selection menu. All parameter selection menus alternate between a blank display and the current selection in the right hand display.</p> <p>Pressing CODE SELECT key in a selection menu cancels the current selection activity and ascends back up to the next higher selection menu (or to Cd48 display mode if that is the next higher).</p> <p>If the operator does not press any key for five seconds the interface reverts to normal system display and the current selection menu is cancelled, but any previously committed changes are retained.</p> <p>Available parameters and parameter ranges are a function of configuration options and previously selected parameters as indicated above.</p> <p>Whenever any pretrip test is initiated, dehumidification-mode goes to OFF.</p> <p>Whenever dehumidification-mode goes to OFF:</p> <ul style="list-style-type: none"> Dehumidification control setpoint goes to 0% RH internally but will then initialize to 95% RH when dehumidification-mode leaves OFF. Evaporator speed select goes to Alt for units without PWM Compressor Control (Cnf57 = Out), Evaporator speed select goes to Hi for units with PWM Compressor Control (Cnf57 = In). DTT setting goes to 25.6°C or 18.0°C, depending on Cnf41. <p>Whenever dehumidification-mode is set to bUIb, DTT setting goes to 18.0°C if it had been set higher.</p> <p>Whenever dehumidification-mode is set to dEhUM, DTT setting goes to 25.6°C or 18.0°C, depending on Cnf41.</p> <p>For units without PWM Compressor Control (Cnf57 = Out):</p> <ul style="list-style-type: none"> Whenever dehumidification control setpoint is set below 65% RH evaporator speed select goes to LO if it had been set to Hi. Whenever dehumidification control setpoint is set above 64% RH evaporator speed select goes to Alt if it had been set to LO. <p>For units with PWM Compressor Control (Cnf57 = In):</p> <ul style="list-style-type: none"> Whenever dehumidification control set point is set below 60% RH, the evaporator fan speed is set to LO, the user has the ability to set the evaporator fan speed to Hi via the keypad. Whenever dehumidification control set point is set equal to or above 60% RH, the evaporator fan speed is set to Hi, the user has the ability to set the evaporator fan speed to LO via the keypad. |
| Display Only Function - Cd49 is a display only function. | | |
| Cd49 | Days Since Last Successful Pretrip | <p>Displays the number of days since last successful pretrip sequence.</p> <p>Press ENTER to view the number of days since the last successful pretrip for Auto1, Auto2, and Auto2 in sequence.</p> <p>Press CODE SELECT to step back through the list and ultimately to exit the Cd49 display.</p> |

Table 4–5 Controller Function Codes

| Code No. | TITLE | DESCRIPTION |
|--|---|--|
| <p>Configurable Functions - Cd50 through Cd53 are user-selectable functions. The operator can change the value of these functions to meet the operational needs of the container.</p> | | |
| Cd50 | CCPC Enable/Disable | <p>"OFF" = disabled. "On" = enabled. "SEtPt" = suspended by setpoint too low. "CAHUM" = suspended by CA or humidity control. "ACT" = suspended by ACT active. "FAIL" = all return temperature probe failure for CCPC. "PrtrP" = pretrip active. "C LIM" = suspended by cool limit logic. "PULL" = pulldown active. ALArM = suspended by shutdown alarm Press enter, arrow keys, and then enter to select "OFF" or "On". If "On" is selected, CCPC operation may be suspended as indicated by one of the suspension codes listed above. If CCPC is not "OFF" and is not suspended, "On" will be displayed.</p> |
| Cd51 | Automatic Cold Treatment (ACT) Mode Parameter Selection | <p>ACT-mode: Cd51 increments of (1 day)_(1hr), Display: default 0_0 done mm-dd this will be display is ACT has completed ACT value On OFF or ----Display /Select: default OFF trEA value °C / °F on 0.1 degree increments Display/Select: default 0.0°C DAyS value "0-99" increments of 1 Display/Select: default "0" ProbE value Probe positions ex '1 2 _ 4' '1 _ 3 _ ' Display: default ---- SPnEW value °C / °F on 0.1_ increments Display/Select: default 10.0°C Initially Cd51 will display current countdown timer increments of (1 day)_(1hr), default 0_0 Pressing ENTER key will take the interface down into a hierarchy of parameter selection menus in the order listed above. Pressing ENTER key in any of the parameter selection menus commits to selection of the currently displayed parameter and causes the interface to descend into the next parameter selection menu. All parameter selection menus alternate between a blank display and the current selection in the right hand display. Pressing CODE SELECT key in a selection menu cancels the current selection activity and ascends back up to the next higher selection menu (or to Cd51 display mode if that is the next higher). If the operator does not press any key for five seconds the interface reverts to normal system display and the current selection menu is cancelled, but any previously committed changes are retained. Available parameters and parameter ranges are a function of configuration options and previously selected parameters as indicated above. Parameter with the exception of Act may not be altered if Cd51 is re-entered if Act is On. When ACT has completed including reaching the new setpoint done on the left display and the MONTH DAY of completion on the right display will be displayed as the second entry in the menu. Turning ACT off clears this entry. This action also resets Cd51 to initial time remaining. ACT must then be turned on to view or modify the additional parameters. Whenever any auto pretrip test or Trip Start is initiated, act-mode goes to OFF.</p> |

Table 4–5 Controller Function Codes

| Code No. | TITLE | DESCRIPTION |
|--|---|--|
| Cd53 | Automatic Set point Change (ASC) Mode Parameter Selection | <p>ASC-mode: Cd53 increments of (1 day)_(1hr), Display: default 0_0 done mm-dd this will be display is ASC has completed ASC value “On” “OFF” Display /Select: default OFF nSC value “1 - 6” (This is the value n for the subsequent entries). SP (n-1) value °C/°F on 0.1 degree increments Display/Select: default 10.0°C DAY (n-1) value “1-99” increments of 1 Display/Select: default 1 SP (n) value °C/°F on 0.1 degree increments Display/Select: default 10.0°C Initially displays current count down timer increments of (1 day)(1hr), default “0_0” Pressing ENTER key will take the interface down into a hierarchy of parameter selection menus in the order listed above. Pressing ENTER key in any of the parameter selection menus selects the currently displayed parameter and causes the interface to descend into the next parameter selection menu. All parameter selection menus alternate between a blank display and the current selection in the right hand display. Pressing CODE SELECT key in a selection menu cancels the current selection activity and ascends back up to the next higher selection menu (or to Cd53 display mode if that is the next higher). If the operator does not press any key for five seconds the interface reverts to normal system display and the current selection menu is cancelled, but any previously committed changes are retained. Available parameters and parameter ranges are a function of configuration options and previously selected parameters as indicated above. Parameter with the exception of ASC may not be altered if Cd53 is re-entered if ASC is On. When ASC has completed including reaching the last setpoint done on the left display and the MONTH DAY of completion on the right display will be displayed as the second entry in the menu. Turning ASC off clears this entry. This action also resets Cd53 to initial time remaining. ASC must then be turned on to view or modify the additional parameters. Whenever any auto Pretrip test or Trip Start is initiated, ASC mode goes to OFF.</p> |
| Display Only Functions - Cd55 through Cd58 are display only functions. | | |
| Cd55 | Discharge Superheat | Cd55 will display the discharge superheat values in °C / °F as calculated by the discharge temperature minus the discharge saturation temperature as calculated from discharge pressure. ----- will be displayed if selection is not valid. |
| Configurable Functions - Cd60 is a user-selectable function. The operator can change the value of this function to meet the operational needs of the container. | | |
| Cd60 | Evaporator Fan Pulsing Temperature Setting | Cd60 contains a selectable temperature range used to determine the engagement point of the Evaporator Fan Pulsing logic. Default setting is --18.1°C. The user may change the temperature by pressing enter, then scrolling to the desired temperature using either arrow key. Press Enter to accept the change. The temperature setting will be retained until either a Pretrip or Trip Start is initiated at which time the temperature will set to the default setting. |
| Cd62 | High Speed Evaporator Fan Setting | <p>Dashed-out if setpoint is in frozen range OR if Cnf66 is configured OFF.</p> <p>This function code is used to force evaporator fan speed to high while temperature control is being performed in the perishable setpoint range. When set to On, evaporator fans operate in high speed regardless of any other active option that can control evaporator fan speed.</p> <p>Following a power cycle, the state of the function select code is retained at its state prior to the power cycle. If On, this function select code will be set to OFF when any trip-start occurs or any pretrip test is initiated.</p> <p>Default is OFF.</p> |

Figure 4.12 Alarm Troubleshooting Sequence

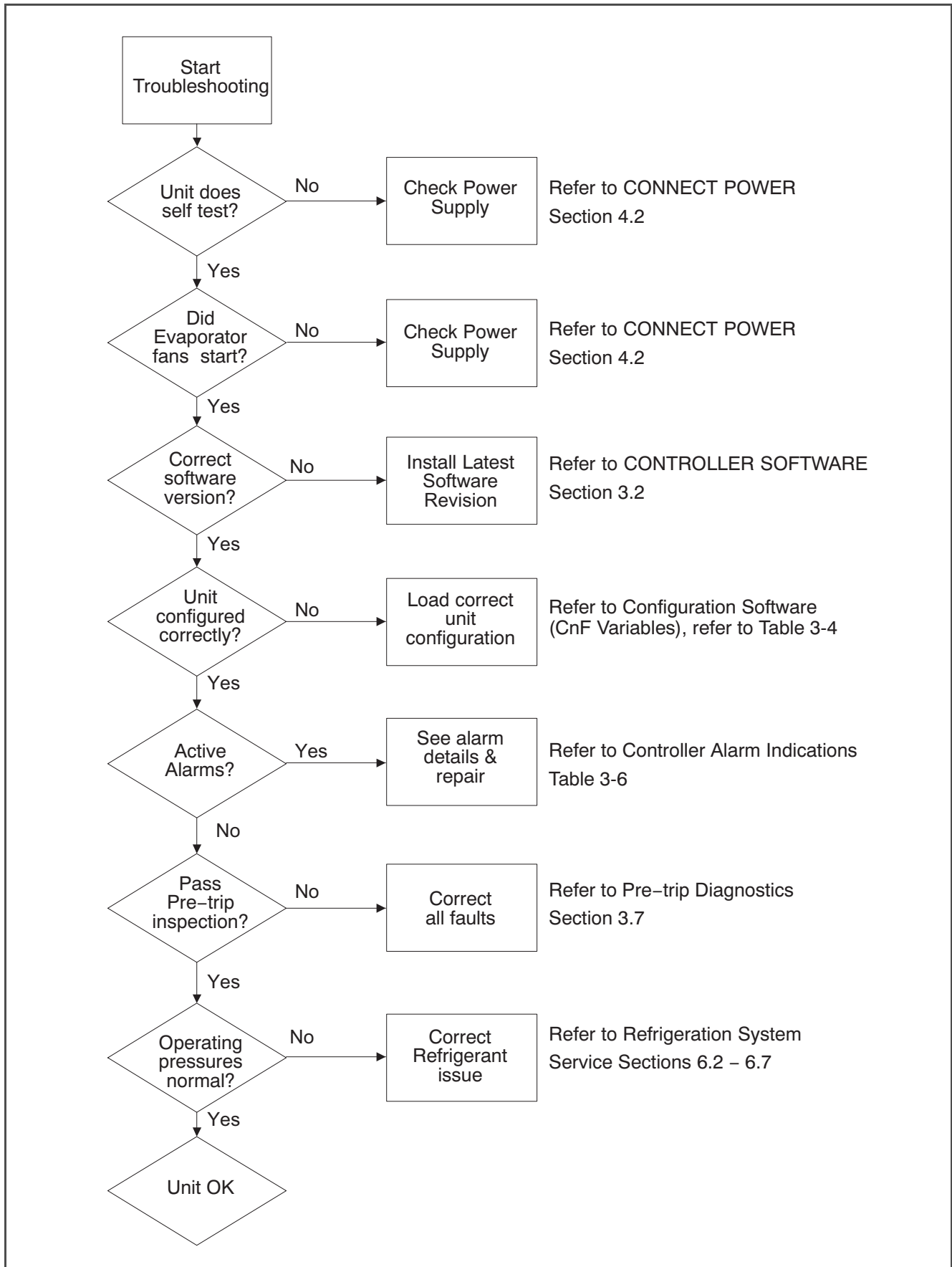

4.11 CONTROLLER ALARM INDICATIONS

| AL05 | | MANUAL DEFROST SWITCH FAILURE |
|---------------|---|---|
| Cause: | Controller has detected continuous Manual Defrost Switch activity for five minutes or more. | |
| | Component | Keypad |
| | Troubleshooting | Power cycle the unit. |
| | Corrective Action | Resetting the unit may correct problem, monitor the unit. If the alarm reappears after 5 minutes replace the keypad. |

| AL06 | | KEYPAD OR KEYPAD HARNESS FAIL |
|---------------|--|---|
| Cause: | Controller has detected one of the keypad keys is continuously activity. | |
| | Component | Keypad or Harness |
| | Troubleshooting | Power cycle the unit. |
| | Corrective Action | Resetting the unit may correct problem, monitor the unit. If the alarm reappears replace the keypad and harness. |

| AL07 | | FRESH AIR VENT OPEN WITH FROZEN SET POINT |
|---------------|---|---|
| Cause: | The VPS is reading greater than 0 CMH while unit is in frozen mode. | |
| | Component | Vent Position Sensor (VPS) |
| | Troubleshooting | Manually reposition vent and confirm using Cd45. Refer to VENT POSITION SENSOR SERVICE Section 7.22 . |
| | Corrective Action | If unable to obtain zero reading, replace defective VPS. |

| AL10 | | CO ₂ SENSOR FAILURE |
|---------------|---|--|
| Cause: | Alarm 10 is triggered when the CO ₂ sensor voltage is operating outside of the 0.9 v to 4.7 v range, or if the sensor is out of range. | |
| | Component | This is a display alarm and has no associated failure action. |
| | Troubleshooting | Refer to eAutoFresh manual. |
| | Corrective Action | The alarm is triggered off when voltage is within operating range. |

| AL11 | | EVAPORATOR FAN 1 IP |
|---------------|--|--|
| Cause: | Alarm 11 is triggered when configured for single evap operation and MC6 sensed high. | |
| | Component | Evaporator Fan 1 |
| | Troubleshooting | The unit will suspend probe check diagnostic logic and disable the probe check portion of defrost cycle. |
| | Corrective Action | AL11 is triggered off when MC6 sensed low. |

| AL12 | | EVAPORATOR FAN 2 IP |
|---------------|---|--|
| Cause: | Alarm 12 is triggered when configured for single evap operation and KB10 sensed high. | |
| | Component | Evaporator Fan 2 |
| | Troubleshooting | The unit will suspend probe check diagnostic logic and disable the probe check portion of defrost cycle. |
| | Corrective Action | AL11 is triggered off when KB10 sensed low. |

| AL15 | | LOSS OF COOLING |
|---------------|---|---|
| Cause: | AL15 is triggered 30 minutes after the completion of a controller initiated probe check defrost if Supply Temperature is more than 0.25°C (0.45°F) above set point. Refer to Section 4.3.17 . | |
| | Component | Refrigerant Level |
| | Troubleshooting | Power cycle the unit. |
| | Corrective Action | Refer to Refrigerant Charge, Section 7.7 Power cycle the unit. |

| AL20 | | CONTROL CONTACTOR FUSE (F3) |
|---------------|--|---|
| Cause: | Control power fuse (F3A or F3B) is open. | |
| | Component | Check F3A, if the fuse is open: |
| | Troubleshooting | Check PA, PB, CH coils for short to ground, if short is found: |
| | Corrective Action | Replace the defective coil. Replace the fuse. |
| | | |
| | Component | Check F3B, if the fuse is open: |
| | Troubleshooting | Check CF, ES, EF, HR coils for short to ground, if short is found, coil is defective. |
| | Corrective Action | Replace the defective coil. Replace the fuse. |
| | | |
| | Component | Check Voltage at the output of F3A and F3B: |
| | Troubleshooting | If voltage is present at both F3A and F3B, it indicates a defective microprocessor. |
| | Corrective Action | Refer to Controller Service Section 7.20 . |

| AL21 | | CONTROL CIRCUIT FUSE (F1/F2) |
|---------------|--|--|
| Cause: | One of the 18 VAC controller fuses (F1/F2) is open. Refer to Cd08. | |
| | Component | System Sensors |
| | Troubleshooting | Check system sensors for short to ground. |
| | Corrective Action | Replace defective sensor(s) |
| | | |
| | Component | Wiring |
| | Troubleshooting | Check wiring for short to ground. |
| | Corrective Action | Repair as needed. |
| | | |
| | Component | Controller |
| | Troubleshooting | Controller may have an internal short. |
| | Corrective Action | Replace controller, refer to Controller Service Section 7.20 . |

| AL22 | | EVAPORATOR IP |
|---------------|---|--|
| Cause: | Evaporator motor internal protector (IP) is open. | |
| | Component | Evaporator Motor |
| | Troubleshooting | Shut down unit, disconnect power, & check Evaporator Motor IP at plug connection pins 4 & 6. |
| | Corrective Action | Replace defective evaporator fan motor, refer to EVAPORATOR FAN MOTOR Service Section 7.14 . |

| AL23 | | LOSS OF PHASE B |
|---------------|--|-----------------------------------|
| Cause: | Controller fails to detect current draw. | |
| | Component | Incoming Power |
| | Troubleshooting | Check incoming power source. |
| | Corrective Action | Correct power source as required. |

| AL24 | | COMPRESSOR IP |
|---------------|---|--|
| Cause: | Compressor internal protector (IP) is open. | |
| | Component | Compressor |
| | Troubleshooting | Shut down unit disconnect power, & check resistance of compressor windings at contactor T1-T2, T2-T3. |
| | Corrective Action | Monitor unit, if alarm remains active or is repetitive replace the compressor at the next available opportunity, refer to COMPRESSOR Service Section 7.8 . |

| AL25 | | CONDENSER IP |
|---------------|--|---|
| Cause: | Condenser fan motor internal protector (IP) is open. | |
| | Component | Insufficient Air Flow |
| | Troubleshooting | Shut down unit and check condenser fan for obstructions. |
| | Corrective Action | Remove obstructions. |
| | | |
| | Component | Condenser Fan Motor |
| | Troubleshooting | Shut down unit, disconnect power, & check Condenser Fan Motor IP at plug connection pins 1 & 2. |
| | Corrective Action | Replace defective condenser fan motor, refer to Condenser Fan Motor Assembly Service Section 7.11 . |

| AL26 | | ALL SENSORS FAILURE: SUPPLY/RETURN PROBES |
|---------------|--------------------------|---|
| Cause: | Sensors out of range. | |
| | Component | All sensors detected as out of range. |
| | Troubleshooting | Perform Pre-trip P5: |
| | Corrective Action | If P5 passes, no further action is required. If P5 fails, replace the defective sensor as determined by P5, refer to TEMPERATURE SENSOR Service Section 7.21 . |

| AL27 | | ANALOG TO DIGITAL ACCURACY FAILURE |
|---------------|---------------------------------|--|
| Cause: | Controller AD converter faulty. | |
| | Component | Controller |
| | Troubleshooting | Power cycle the unit. If the alarm persists, it indicates a defective microprocessor. |
| | Corrective Action | Replace defective microprocessor, refer to Controller Service Section 7.20 . |

| AL29 | | AUTOFRESH FAILURE |
|---------------|---|---|
| Cause: | Alarm 29 is triggered if CO ₂ or O ₂ level is outside of the limit range and the vent position is at 100% for longer than 90 minutes. | |
| | Component | Alarm LED will be activated and user intervention is required. |
| | Troubleshooting | Refer to eAutoFresh manual. |
| | Corrective Action | The alarm is triggered off when atmospheric conditions are within limit settings. |

| AL50 | | AIR VENT POSITION SENSOR (VPS) |
|---------------|--------------------------|--|
| Cause: | VPS Sensor out of range. | |
| | Component | Vent Position Sensor (VPS) |
| | Troubleshooting | Make sure VPS is secure. |
| | Corrective Action | Manually tighten panel. |
| | | |
| | Component | Vent Position Sensor (VPS) |
| | Troubleshooting | If the alarm persists, replace the sensor or the assembly. |
| | Corrective Action | Replace VPS. |

| AL51 | | EEPROM FAILURE |
|---------------|---------------------------|--|
| Cause: | Controller Memory Failure | |
| | Component | Controller |
| | Troubleshooting | Pressing the ENTER key when CLEAR is displayed will result in an attempt to clear the alarm. |
| | Corrective Action | If action is successful (all alarms are inactive), AL51 will be reset. |
| | | |
| | Component | Controller |
| | Troubleshooting | Power cycle the unit. If the alarm persists, it indicates defective controller memory. |
| | Corrective Action | Replace defective controller, refer to Controller Service Section 7.20 . |

| AL52 | | EEPROM ALARM LIST FULL |
|---------------|---------------------------|--|
| Cause: | Alarm list queue is full. | |
| | Component | Active Alarms |
| | Troubleshooting | Repair any alarms in the queue that are active. Indicated by AA. |
| | Corrective Action | Clear alarms, refer to CONTROLLER ALARMS Table 4-6 . |

| AL53 | | BATTERY PACK FAILURE |
|---------------|--------------------------|---|
| Cause: | Battery voltage low | |
| | Component | Battery |
| | Troubleshooting | If this alarm occurs on start up, allow a unit fitted with rechargeable batteries to operate for up to 24 hours to charge rechargeable batteries sufficiently. Once fully charged, the alarm will deactivate. |
| | Corrective Action | To clear the alarm press ENTER and ALT simultaneously at the startup of Cd19 (Battery Check). If alarm persists, replace the battery pack, refer to Section 7.20.5 Battery Replacement. |

| AL54 | | PRIMARY SUPPLY SENSOR (STS) |
|---------------|--|---|
| Cause: | Invalid Supply Temperature Sensor (STS) reading. | |
| | Component | Supply Temperature Sensor (STS) |
| | Troubleshooting | Perform Pre-trip P5: |
| | Corrective Action | If P5 passes, no further action is required. If P5 fails, replace the defective sensor as determined by P5, refer to TEMPERATURE SENSOR Service Section 7.21 . |

| AL56 | | PRIMARY RETURN SENSOR (RTS) |
|---------------|--|---|
| Cause: | Invalid Return Temperature Sensor (RTS) reading. | |
| | Component | Return Temperature Sensor (RTS) |
| | Troubleshooting | Perform Pre-trip P5: |
| | Corrective Action | If P5 passes, no further action is required. If P5 fails, replace the defective sensor as determined by P5, refer to TEMPERATURE SENSOR Service Section 7.21 . |

| AL57 | | AMBIENT SENSOR (AMBS) |
|---------------|--|---|
| Cause: | Invalid Ambient Temperature Sensor (AMBS) reading. | |
| | Component | Ambient Temperature Sensor (AMBS) |
| | Troubleshooting | Test the AMBS, refer to TEMPERATURE SENSOR Service Section 7.21 . |
| | Corrective Action | Replace AMBS if defective, refer to TEMPERATURE SENSOR Service Section 7.21 . |

| AL58 | | COMPRESSOR HIGH PRESSURE SAFETY (HPS) |
|---------------|---|--|
| Cause: | High pressure safety switch remains open for at least one minute. | |
| | Component | High Pressure Switch (HPS) |
| | Troubleshooting | Test the HPS; refer to High Pressure Switch, Section 7.9 . |
| | Corrective Action | Replace HPS if defective, refer to High Pressure Switch, Section 7.9 . |
| | | |
| | Component | Refrigeration System |
| | Troubleshooting | Check unit for air flow restrictions. |
| | Corrective Action | Clean or remove any debris from coils. |

| AL59 | | HEATER TERMINATION THERMOSTAT (HTT) |
|---------------|--|---|
| Cause: | Heat Termination Thermostat (HTT) is open. | |
| | Component | Alarm 59 is triggered by the opening of the Heat Termination Thermostat (HTT) and will result in the disabling of the heater. |
| | Troubleshooting | Check for 24 volts at test point TP10, if no voltage at TP10 after unit has reached set point HTT is open. |
| | Corrective Action | Replace HTT if defective. |

| AL60 | | DEFROST TEMPERATURE SENSOR (DTS) |
|---------------|--|--|
| Cause: | Failure of the Defrost Temperature Sensor (DTS) to open. | |
| | Component | Defrost Temperature Sensor (DTS) |
| | Troubleshooting | Test the DTS; refer to Sensor Checkout Procedure Section 7.21.1 . |
| | Corrective Action | Replace the DTS if defective, refer to Sensor Replacement Section 7.21.2 . |

| AL61 | | HEATER CURRENT DRAW FAULT |
|---------------|--|---|
| Cause: | Improper current draw during heat or defrost mode. | |
| | Component | Heater(s) |
| | Troubleshooting | While in heat or defrost mode, check for proper current draw at heater contactors, refer to Electrical Data Section 3.3 . |
| | Corrective Action | Replace heater(s) if defective, refer to Section 7.13 Evaporator Heater Removal and Replacement. |
| | | |
| | Component | Contactors |
| | Troubleshooting | Check voltage at heater contactor on the heater side. If no voltage present: |
| | Corrective Action | Replace heater contact or if defective. |

| AL63 | | CURRENT LIMIT |
|---------------|-------------------------------------|--|
| Cause: | Unit operating above current limit. | |
| | Component | Refrigeration System |
| | Troubleshooting | Check unit for air flow restrictions. |
| | Corrective Action | Clean or remove any debris from coils. |
| | | |
| | Component | Refrigeration System |
| | Troubleshooting | Check unit for proper operation. |
| | Corrective Action | Repair as needed. |
| | | |

| AL63 | | CURRENT LIMIT |
|------|--------------------------|--|
| | Component | Power supply |
| | Troubleshooting | Confirm supply voltage/frequency is within specification and balanced according to Electrical Data Section 3.3 . |
| | Corrective Action | Correct power supply. |
| | | |
| | Component | Current limit set too low |
| | Troubleshooting | Check current limit setting Code Cd32. |
| | Corrective Action | The current limit can be raised (maximum of 23 amps) using Cd32. |

| AL64 | | DISCHARGE TEMPERATURE SENSOR (CPDS) |
|---------------|--|---|
| Cause: | Discharge Temperature sensor out of range. | |
| | Component | Discharge temperature sensor (CPDS) |
| | Troubleshooting | Test the CPDS; refer to Temperature Sensor Service Section 7.21 . |
| | Corrective Action | Replace the CPDS if defective, refer to Temperature Sensor Service Section 7.21 . |

| AL65 | | DISCHARGE PRESSURE TRANSDUCER (DPT) |
|---------------|--|---|
| Cause: | Compressor Discharge Transducer is out of range. | |
| | Component | Compressor Discharge Transducer (DPT) |
| | Troubleshooting | Confirm accurate DPT pressure readings, refer to Manifold Gauge Set Section 7.2 . |
| | Corrective Action | Replace DPT if defective |

| AL66 | | (SPT) SUCTION PRESSURE TRANSDUCER, (EPT) EVAPORATOR PRESSURE TRANSDUCER |
|---------------|---|--|
| Cause: | Suction Pressure Transducer (SPT) out of range. | |
| | Component | Suction Pressure Transducer (SPT) |
| | Troubleshooting | Confirm accurate EPT and SPT pressure readings, refer to Manifold Gauge Set Section 7.2 . Performing a Pre-trip 5-9 test will also check the transducers. |
| | Corrective Action | Replace EPT/SPT if defective |
| | | |
| | Component | Suction Pressure Transducer (SPT) |
| | Troubleshooting | Monitor |
| | Corrective Action | If the alarm persists, it may indicate a failing compressor, refer to Compressor Service Section 7.8 . |

| AL67 | | HUMIDITY SENSOR |
|---------------|--|--|
| Cause: | Humidity Sensor (HS) reading out of range. | |
| | Component | Humidity Sensor (HS) |
| | Troubleshooting | Make sure the humidity sensor is properly connected in the socket and the wires have not been damaged. |
| | Corrective Action | Monitor, replace HS if alarm persists. |

| AL68 | | CPC PRESSURE SENSOR (PS3) |
|---------------|---|---|
| Cause: | Condenser Pressure Transducer (CPC) out of range. | |
| | Component | Condenser Pressure Transducer (CPC) |
| | Troubleshooting | NA |
| | Corrective Action | Unit will disable Condenser Pressure Control if Configured. |

| AL69 | | SUCTION TEMP SENSOR (CPSS) |
|---------------|---|---|
| Cause: | Suction Temperature Sensor (CPSS) out of range. | |
| | Component | Suction Temperature Sensor (CPSS) |
| | Troubleshooting | Test the CPSS, refer to Temperature Sensor Service Section 7.21 . |
| | Corrective Action | Replace CPSS if defective, refer to Temperature Sensor Service Section 7.21 . |

| AL70 | | SECONDARY SUPPLY SENSOR (SRS) |
|---------------|--|---|
| Cause: | Secondary Supply Sensor (SRS) is out of range. | |
| | Component | Secondary Supply Sensor (SRS) |
| | Troubleshooting | Perform Pre-trip P5: |
| | Corrective Action | If P5 passes, no further action is required. If P5 fails, replace the defective sensor as determined by P5, refer to Temperature Sensor Service Section 7.21 . |

| AL71 | | SECONDARY RETURN SENSOR (RRS) |
|---------------|--|---|
| Cause: | Secondary Return Sensor (RRS) is out of range. | |
| | Component | Secondary Return Sensor (RRS) |
| | Troubleshooting | Perform Pre-trip P5: |
| | Corrective Action | If P5 passes, no further action is required. If P5 fails, replace the defective sensor as determined by P5, refer to Temperature Sensor Service Section 7.21 . |

| AL72 | CONTROL TEMP OUT OF RANGE | |
|---------------|---|---|
| Cause: | After the unit goes in-range for 30 minutes then out of range for a continuous 120 minutes. | |
| | Component | Refrigeration System |
| | Troubleshooting | Ensure unit is operating correctly. |
| | Corrective Action | Power cycle unit. Control Temperature is in In-range. Any Pre-trip mode, re sets the timers |

Table 4–6 Controller Alarm Indications

| NOTE | | | | | | | | | | | | | | | | | | | | | | | | |
|---|---|---|---|-------------|-------------------|--|------------------------------|--|-------------------------|---|-----------|-----|-----------|-----|-------------------|--|------------------------|----------------------------------|--------------------------|---|--------------------------|-------------------------------------|--------------------------|-------------------------------------|
| <p>If the controller is configured for four probes without a DataCORDER, the DataCORDER alarms AL70 and AL71 will be processed as Controller alarms AL70 and AL71. Refer to Table 4–10.</p> | | | | | | | | | | | | | | | | | | | | | | | | |
| ERR # | Internal Microprocessor Failure | <p>The controller performs self-check routines. If an internal failure occurs, an ERR alarm will appear on the display. This is an indication the controller needs to be re placed.</p> | | | | | | | | | | | | | | | | | | | | | | |
| | | <table border="1" style="width: 100%; border-collapse: collapse;"> <thead> <tr> <th style="text-align: left;">ERROR</th> <th style="text-align: left;">DESCRIPTION</th> </tr> </thead> <tbody> <tr> <td>ERR 0-RAM failure</td> <td>Indicates that the controller working memory has failed.</td> </tr> <tr> <td>ERR 1-Program Memory failure</td> <td>Indicates a problem with the controller program.</td> </tr> <tr> <td>ERR 2-Watchdog time-out</td> <td>The controller program has entered a mode whereby the controller program has stopped executing.</td> </tr> <tr> <td>ERR 3-N/A</td> <td>N/A</td> </tr> <tr> <td>ERR 4-N/A</td> <td>N/A</td> </tr> <tr> <td>ERR 5-A-D failure</td> <td>The controller's Analog to Digital (A-D) converter has failed.</td> </tr> <tr> <td>ERR 6-IO Board failure</td> <td>Internal program/update failure.</td> </tr> <tr> <td>ERR 7-Controller failure</td> <td>Internal version/firmware incompatible.</td> </tr> <tr> <td>ERR 8-DataCORDER failure</td> <td>Internal DataCORDER memory failure.</td> </tr> <tr> <td>ERR 9-Controller failure</td> <td>Internal controller memory failure.</td> </tr> </tbody> </table> | ERROR | DESCRIPTION | ERR 0-RAM failure | Indicates that the controller working memory has failed. | ERR 1-Program Memory failure | Indicates a problem with the controller program. | ERR 2-Watchdog time-out | The controller program has entered a mode whereby the controller program has stopped executing. | ERR 3-N/A | N/A | ERR 4-N/A | N/A | ERR 5-A-D failure | The controller's Analog to Digital (A-D) converter has failed. | ERR 6-IO Board failure | Internal program/update failure. | ERR 7-Controller failure | Internal version/firmware incompatible. | ERR 8-DataCORDER failure | Internal DataCORDER memory failure. | ERR 9-Controller failure | Internal controller memory failure. |
| | | ERROR | DESCRIPTION | | | | | | | | | | | | | | | | | | | | | |
| | | ERR 0-RAM failure | Indicates that the controller working memory has failed. | | | | | | | | | | | | | | | | | | | | | |
| | | ERR 1-Program Memory failure | Indicates a problem with the controller program. | | | | | | | | | | | | | | | | | | | | | |
| | | ERR 2-Watchdog time-out | The controller program has entered a mode whereby the controller program has stopped executing. | | | | | | | | | | | | | | | | | | | | | |
| | | ERR 3-N/A | N/A | | | | | | | | | | | | | | | | | | | | | |
| | | ERR 4-N/A | N/A | | | | | | | | | | | | | | | | | | | | | |
| | | ERR 5-A-D failure | The controller's Analog to Digital (A-D) converter has failed. | | | | | | | | | | | | | | | | | | | | | |
| | | ERR 6-IO Board failure | Internal program/update failure. | | | | | | | | | | | | | | | | | | | | | |
| | | ERR 7-Controller failure | Internal version/firmware incompatible. | | | | | | | | | | | | | | | | | | | | | |
| | | ERR 8-DataCORDER failure | Internal DataCORDER memory failure. | | | | | | | | | | | | | | | | | | | | | |
| | | ERR 9-Controller failure | Internal controller memory failure. | | | | | | | | | | | | | | | | | | | | | |
| | | <p>In the event that a failure occurs and the display cannot be updated, the status LED will indicate the appropriate ERR code using Morse code as shown below.</p> | | | | | | | | | | | | | | | | | | | | | | |
| <p>E R R 0 to 9</p> | | | | | | | | | | | | | | | | | | | | | | | | |
| <p>ERR0 = ----</p> | | | | | | | | | | | | | | | | | | | | | | | | |
| <p>ERR1 =----</p> | | | | | | | | | | | | | | | | | | | | | | | | |
| <p>ERR2 =----</p> | | | | | | | | | | | | | | | | | | | | | | | | |
| <p>ERR3 =----</p> | | | | | | | | | | | | | | | | | | | | | | | | |
| <p>ERR4 =----</p> | | | | | | | | | | | | | | | | | | | | | | | | |
| <p>ERR5 =----</p> | | | | | | | | | | | | | | | | | | | | | | | | |
| <p>ERR6 =----</p> | | | | | | | | | | | | | | | | | | | | | | | | |
| <p>ERR7 =----</p> | | | | | | | | | | | | | | | | | | | | | | | | |
| <p>ERR8 =----</p> | | | | | | | | | | | | | | | | | | | | | | | | |
| <p>ERR9 =----</p> | | | | | | | | | | | | | | | | | | | | | | | | |
| Entr StPt | Enter Set point (Press Arrow & Enter) | The controller is prompting the operator to enter a set point. | | | | | | | | | | | | | | | | | | | | | | |
| LO | Low Main Voltage (Function Codes Cd27-38 disabled and NO alarm stored.) | This message will be alternately displayed with the set point whenever the supply voltage is less than 75% of its proper value. | | | | | | | | | | | | | | | | | | | | | | |

4.12 CONTROLLER PRE-TRIP TEST CODES

Table 4-7 Controller Pre-Trip Test Codes

| NOTE | | |
|---|---|--|
| <p>Auto or Auto1 menu includes the: P, P1, P2, P3, P4, P5, P6 and rSLts. Auto2 menu includes P, P1, P2, P3, P4, P5, P6, P7, P8, P9, P10 and rSLts. Auto3 menu includes P, P1, P2, P3, P4, P5, P6, P7, P8 and rSLts</p> | | |
| P0-0 | PreTrip Initiated: Configuration Display, Indicator Lamps, LEDs, and Displays | <p>Container identifier code, Cd18 Software Revision Number, Cd20 Container Unit Model Number, & configuration database identifier CFMMYYDD are displayed in sequence.</p> <p>Next the unit will indicate the presence or non-presence of an RMU according to whether any RMU inquiry messages have been received since the unit was booted.</p> <p>Units equipped with Autoslide Enabled (Cnf44) will cause the vent to seek to its closed position, followed by two sequences of opening to 100% and returning to the closed position. No other Autoslide mode of operation will be available until the two cycles of opening and closing have completed.</p> <p>Since the system cannot recognize lights and display failures, there are no test codes or results associated with this phase of Pretrip. To know if the test passes the operator must observe that the LCD display elements and the indicator lights behave as described below.</p> |
| <p>P1 Tests - Heaters Current Draw: Heater is turned on, then off. Current draw must fall within specified range. No other system components will change state during this test.</p> | | |
| P1-0 | Heaters On Test | <p>Heater starts in the off condition, current draw is measured, and then the heater is turned on. After 15 seconds, the current draw is measured again. The change in current draw is then recorded.</p> <p>Test passes if the change in current draw test is in the range specified.</p> |
| P1-1 | Heaters Off Test | <p>Heater is then turned off. After 10 seconds the current draw is measured. The change in current draw is then recorded.</p> <p>Test passes if change in current draw is in the range specified.</p> |
| <p>P2 Tests - Condenser Fan Current Draw: Condenser fan is turned on, then off. Current draw must fall within specified range. No other system components will change state during this test.</p> | | |
| P2-0 | Condenser Fan On Test | <p>Condenser fan starts in the off condition, current draw is measured, and condenser fan is then turned on. After 15 seconds the current draw is measured again. The change in current draw is then recorded.</p> <p>Test passes if change in current draw test is in the specified range.</p> |
| P2-1 | Condenser Fan Off Test | <p>Condenser fan is then turned off. After 10 seconds the current draw is measured. The change in current draw is then recorded.</p> <p>Test passes if change in current draw test is in the specified range.</p> |
| <p>P3 Tests - Low Speed Evaporator Fan Current Draw: The system must be equipped with a low speed evaporator fan, as determined by CnF02, the Evaporator Fan Speed Select configuration variable. Low speed evaporator fan is turned on, then off. Current draw must fall within specified range. No other system components will change state during this test.</p> | | |
| NOTE | | |
| <p>If unit configured for single evaporator fan operation and either AL11 or AL12 is active at the start of either test, then the test will fail immediately. If AL11 or AL12 become active during the test, then the test will fail upon conclusion of the test.</p> | | |
| P3-0 | Low Speed Evaporator Fans On Test | <p>High speed evaporator fans will be turned on for 20 seconds, the fans will be turned off for 4 seconds, current draw is measured, and then the low speed evaporator fans are turned on. After 60 seconds the current draw is measured again. The change in current draw is then recorded.</p> <p>Test passes if change in current draw test is in the specified range.</p> |
| P3-1 | Low Speed Evaporator Fan Off Test | <p>Low speed evaporator fans are then turned off. After 10 seconds the current draw is measured. The change in current draw is then recorded.</p> <p>Test passes if change in current draw test is in the specified range.</p> |

Table 4–7 Controller Pre-Trip Test Codes

| | | |
|---|--------------------------------------|--|
| <p>P4 Tests - High Speed Evaporator Fans Current Draw: High speed evaporator fans are turned on, then off. Current draw must fall within specified range and measured current changes must exceed specified ratios. No other system components will change state during this test.</p> | | |
| <p>NOTE</p> <p>If unit configured for single evaporator fan operation and either AL11 or AL12 is active at the start of either test, the test will fail immediately. If AL11 or AL12 become active during the test, the test will fail upon conclusion of the test.</p> | | |
| P4-0 | High Speed Evaporator Fan Motors On | <p>Evaporator fans start in the off condition, current draw is measured, then high speed evaporator fans will be turned on. After 60 seconds the current draw is measured again. The change in current draw is then recorded.</p> <p>Test passes if change in current draw in the specified range AND measured current changes exceed specified ratios.</p> <p>If the three phase motors are configured IN, the change ratio test is skipped.</p> |
| P4-1 | High Speed Evaporator Fan Motors Off | <p>High speed evaporator fans are then turned off. After 10 seconds the current draw is measured. The change in current draw is then recorded.</p> <p>Test passes if change in current draw test is in the specified range.</p> |
| <p>P5 Tests - Air Stream Temperature Sensor Tests: Tests the validity of the Air Stream Temperature Sensors.</p> | | |
| P5-0 | Supply / Return Probe Test | <p>The High Speed Evaporator Fan is turned on and run for eight minutes, with all other outputs de-energized. A temperature comparison is made between the return and supply probes.</p> <p>Test passes if temperature comparison falls within the specified range.</p> <p style="text-align: center;">NOTE</p> <p>If this test fails, P50 and FAIL will be displayed. If both Probe tests (this test and the PRIMARY / SECONDARY) pass, the display will read P5 PASS.</p> |
| P5-1 | Supply Probe Test | <p>This test is for units equipped with secondary supply probe only.</p> <p>The temperature difference between primary supply probe and secondary supply probe is compared.</p> <p>Test passes if temperature comparison falls within the specified range.</p> <p style="text-align: center;">NOTE</p> <p>If this test fails, P51 and FAIL will be displayed. If both Probe tests (this and the SUPPLY/ RETURN TEST) pass, because of the multiple tests, the display will read 'P 5' 'PASS'.</p> |
| P5-2 | Return Probe Test | <p>For units equipped with secondary return probe only.</p> <p>The temperature difference between primary return probe and secondary return probe is compared.</p> <p>Test passes if temperature comparison falls within the specified range.</p> <p style="text-align: center;">NOTES</p> <ol style="list-style-type: none"> 1. If this test fails, P52 and FAIL will be displayed. If both Probe tests (this test and the SUPPLY/ RETURN) pass, because of the multiple tests, the display will read P 5, PASS. 2. The results of PreTrip tests 50, 51 and 52 will be used to activate or clear control probe alarms. |
| P5-3 | Evaporator Fan Direction Test | <p>With evaporator fan running on high speed, measure the temperature difference between the primary supply and primary return probes. Turn the heaters on for 60 seconds then measure the temperature difference between the primary supply and primary return probes.</p> <p>After 60 seconds this test is forced to PASS irrespective of differential change in primary supply temperature and primary return temperature.</p> <p>Test P5-0 must pass before this test is run.</p> |

Table 4-7 Controller Pre-Trip Test Codes

| | | |
|--|--|--|
| P5-4 - P5-9 | | Not Applicable |
| P5-10 | Humidity Sensor Controller Configuration Verification Test | This is a Pass/Fail/Skip test of the humidity sensor configuration. Test passes if the controller configuration has humidity sensor in. Test fails if the controller configuration has humidity sensor out and Vout is greater than 0.20 Volts for the humidity sensor. Test is skipped if the controller configuration has the humidity sensor out and Vout is less than 0.20 Volts. Unit must be configured with a Humidity Sensor for this test is run. |
| P5-11 | Humidity Sensor Installation Verification Test | This is a Pass/Fail test of humidity sensor installation (sensor is present). Test passes if Vout is greater than 0.20 Volts for the humidity sensor. Test fails if Vout is less than 0.20 Volts for the humidity sensor. Test P5-10 must pass before this test is run. |
| P5-12 | Humidity Sensor Range Check Test | This is a Pass/Fail test of the Humidity Sensor Range. Test passes if Vout for the humidity sensor is between 0.33 Volts and 4 Volts. Test fails if Vout is outside of this range. Test P5-11 must pass before this test is run. |
| P6 Tests - Compressor and Refrigerant Valves: This section of testing deals with the Compressor and the two Compressor valves: Suction Modulation Valve and Quench Valve. | | |
| P6-0 | Compressor On | A current draw test is performed before the compressor is started. The compressor is started, the SMV is opened, and another current draw test is performed. Test Passes if the change in compressor current draw is within the specified range. |
| P6-1, P6-H, P6-L | Not Applicable | These tests are not run for Single Speed Compressors. |
| P6-2 | Suction Modulation Valve (Open and Closed) | The compressor and fans continue to run from the previous test. The quench valve (if configured) will operate as in normal control mode. The SMV is closed to 0% open, current and condenser pressure readings are taken. The SMV is opened to 50% with continuous current and condenser pressure readings taken to establish maximum values. The SMV is returned to 0% open and final readings are taken. Test passes if the calculated difference in current at the 50% open position are above a specified value before and after opening of the SMV, OR the calculated difference in condenser pressure at the 50% open position are above a specified value before and after opening of the SMV. |
| P6-3 | Quench Valve Test | To run this test, the system must be equipped with a solenoid quench valve as determined by CnF12, (TXV/Solenoid Quench Valve), and ambient temperature must be greater than -12°C. Compressor suction temperature is measured with the Quench valve closed, the Quench valve is energized and the suction temperature drop is checked. Test passes if suction temperature is within the valid range. |
| P6-4 | Not Applicable | This test is not run for units configured with a stepper type SMV. |
| P6-5 | Not Applicable | This test is not run, units with stepper type SMVs are not configured with a by pass valve. |
| P6-6 | Not Applicable | This test is only run on systems that have an Unloader as indicated by CnF13 (Unloader). |
| NOTE | | |
| P70 & P8 are included with the Auto2 & Auto 3 only. P90 through P10 are included with Auto2 only. | | |

Table 4–7 Controller Pre-Trip Test Codes

P7 Tests - High Pressure Tests: Unit is run at full capacity without condenser fan running to make sure that the HPS opens and closes properly.

| | | |
|------|-----------------------------|---|
| P7-0 | High Pressure Switch Closed | <p>With the unit running, the condenser fan is de-energized, and a 15 minute timer is started. The right display shows discharge pressure if the unit is equipped with a discharge pressure transducer (DPT). If no DPT is installed, the condenser pressure transducer (CPT) reading will be displayed.</p> <p>Test is skipped if:</p> <ul style="list-style-type: none"> Sensed ambient temperature is less than 7°C (45°F) Return air temperature is less than 17.8°C (0°F) The water pressure switch (WP) is open, indicating that the unit is operating with a water-cooled condenser <p>Test is skipped if the unit does NOT have:</p> <ul style="list-style-type: none"> A compressor discharge sensor (CPDS) A discharge pressure transducer (DPT) A condenser pressure transducer (CPT) <p>Test passes if the HPS opens within 15 minutes.</p> <p>Test immediately fails if the following inputs are sensed to be invalid:</p> <ul style="list-style-type: none"> Compressor discharge sensor (CPDS) Discharge pressure transducer (DPT) Condenser pressure transducer (CPT) Return temperature sensor (RTS) Ambient sensor (AMBS) <p>Test will also fail if:</p> <ul style="list-style-type: none"> HPS fails to open within 15 minutes Discharge temperature exceeds 138°C (280°F) Discharge temperature is less than or equal to ambient temperature plus 5°C (9°F) CPT or DPT pressure exceeds 27.42kg/cm₂ (390psig) |
| P7-1 | High Pressure Switch Open | <p>Test P70 must pass for P71 to execute.</p> <p>The condenser fan is started and a 60 second timer is started.</p> <p>Test passes if the high pressure switch (HPS) closes within the 60-second time limit, otherwise, it fails.</p> |

P8 Tests Perishable Mode Tests: Pretrip tests P70 and P71 must have passed or have been skipped for these tests to execute.

| | | |
|------|---------------------------|--|
| P8-0 | Perishable Mode Heat Test | <p>If the container temperature is below 15.6°C (60°F), the set point is changed to 15.6°C, and a 60-minute timer is started. The left display will read P80. The control will then heat the container until 15.6°C is reached.</p> <p>If the container temperature is above 15.6°C at the start of the test, then the test proceeds immediately to test P81 and the left display will change to P81.</p> <p>The test fails if the 180-minute timer expires before the control temperature reaches set point. The display will read P80, FAIL.</p> |
|------|---------------------------|--|

Table 4–7 Controller Pre-Trip Test Codes

| | | |
|--|--|---|
| P8-1 | Perishable Mode Pull Down Test / eAutofresh CO ₂ Sensor Calibration | <p>Control temperature must be at least 15.6°C (60°F).</p> <p>The set point is changed to 0°C (32°F), and a 180-minute timer is started. The left display will read P81, the right display will show the supply air temperature. The unit will then start to pull down the temperature to the 0°C set point.</p> <p>The test passes if the container temperature reaches set point before the 180-minute timer expires.</p> <p>On units where the CO₂ Sensor Status indicates that a CO₂ sensor is present, calibration of the CO₂ sensor will be attempted during P8-1. Once P8-1 begins, calibration will be attempted when the supply temperature goes below 5°C. If the CO₂ sensor voltage reads within the 0.95 <> 1.15Vdc range before the end of P8-1, the sensor will be calibrated by holding the CO₂ zero line low for 4 seconds. Once calibration is performed, the sensor voltage will be verified to make sure it is in the 0.95 to 1.05 Vdc range. If the voltage is not within this range, CO₂ sensor calibration fails.</p> |
| P8-2 | Perishable Mode Maintain Temperature Test | <p>Test P81 must pass for P82 to execute.</p> <p>A fifteen minute timer is started, and the system will attempt to minimize control temperature error (supply temperature minus setpoint) until the timer expires. The control temperature will be sampled each minute starting at the beginning of P82.</p> <p>During P82, the left display will read P82, and the right display will show the supply air temperature.</p> <p>When the test is completed, the average control temperature error will be compared to the pass/fail criteria.</p> <p>Test passes if the average temperature error is within +/- 1.0°C.</p> <p>Test fails if the average temperature error is greater than +/- 1.0°C, or if the Data-Corder supply temperature probe is invalid. If the test fails, the control probe temperature will be recorded as -50.0°C.</p> |
| <p>P9 Test - DTT Close and Open Test: The DTT in this control is not a physical device, with actual metallic contacts, it is a software function that acts similar to a thermostat. Using various temperature inputs, the DTT function determines whether a thermostat mounted on the Evaporator Coil would have OPEN or CLOSED contacts. Primarily, the DTT function operates based on the temperature reading from the Defrost Termination Sensor</p> | | |
| P9-0 | DTT Closed and Open Test | <p>During P90 the defrost temperature sensor (DTS) reading will be displayed on the left display. The right display will show the supply air temperature.</p> <p>The unit will run FULL COOL for 30 minutes maximum until the DTT is considered closed. Once the DTT is considered closed, the unit simulates defrost by running the heaters for up to two hours, or until the DTT is considered open.</p> <p>Test fails if:</p> <ul style="list-style-type: none"> The DTT is not considered closed after the 30 minutes of full cooling HTT opens when DTT is considered closed or if return air temperature rises above 248°C (120°F). <p>Test passes if the DTT is considered open within the 2 hour heat cycle time limit.</p> |

Table 4–7 Controller Pre-Trip Test Codes

| P10 Tests - Frozen Mode Tests: | | |
|---------------------------------------|---------------------------------------|--|
| P10-0 | Frozen Mode Setup Test | <p>After completion of the Defrost Test, if the container temperature is below 7.2°C, the setpoint is changed to 7.2°C, and a 180 minute timer is started. The control will then be placed in the equivalent of normal heating.</p> <p>If the container temperature is above 7.2°C at the start of the test, then the test proceeds immediately to test P101.</p> <p>During P10, the control temperature will be shown on the right display.</p> <p>Test fails if the 180 minute timer expires before the control temperature reaches setpoint - 0.3°C. If the test fails, it will not auto-repeat.</p> <p>There is no pass display for this test. Once the control temperature reaches set point, the test proceeds to test 10-1.</p> |
| P10-1 | Frozen Mode Pulldown Test | <p>When the container temperature is greater than or equal to the 7.2°C (45°F) set point which was set in the frozen mode heat test, the left display will read P101 and the right display will show the return air temperature. The set point will then be changed to 17.7°C (0°F). The unit will then have a maximum of three hours to pull the container temperature down to the 17.7°C set point.</p> <p>If this occurs within the three hour time limit, the test passes. If pulldown is not completed within the three hour time, the test fails.</p> <p>Upon failure and when initiated by an automatic Pretrip sequence, P101 will auto-repeat by starting P100 over again.</p> |
| P10-2 | Frozen Mode Maintain Temperature Test | <p>Test P101 must pass for P102 to execute.</p> <p>A fifteen minute timer is started, and the system will attempt to minimize control temperature error (return temperature minus setpoint) until the timer expires. The control temperature will be sampled each minute starting at the beginning of P102.</p> <p>During P101, the left display will read P102 and the right display will show return air temperature.</p> <p>When the test is completed, the average control temperature error will be compared to the pass/fail criteria.</p> <p>Test passes if the average temperature error is within +/-1.6°C.</p> <p>Test fails if the average temperature error is greater than +/-1.6°C, or if the Data-CORDER supply temperature probe is invalid. If the test fails, the control probe temperature will be recorded as -50.0°C.</p> <p>Upon failure and when initiated by an automatic Pretrip sequence, P102 will auto-repeat by starting P100 over again.</p> |

Table 4–8 DataCORDER Function Code Assignments

| NOTE | | |
|--|------------------------------------|--|
| Inapplicable Functions Display “-----” | | |
| To Access: Press ALT. MODE key then CODE SELECT key | | |
| Code No. | TITLE | DESCRIPTION |
| dC1 | Recorder Supply Temperature | Current reading of the supply recorder sensor. |
| dC2 | Recorder Return Temperature | Current reading of the return recorder sensor. |
| dC3-5 | USDA 1,2,3 Temperatures | Current readings of the three USDA probes. |
| dC6-13 | Network Data Points 18 | Current values of the network data points (as configured). Data point 1 (Code 6) is generally the humidity sensor and its value is obtained from the Controller once every minute. |
| dC14 | Cargo Probe 4 Temperature | Current reading of the cargo probe #4. |
| dC15-19 | Future Expansion | These codes are for future expansion, and are not in use at this time. |
| dC20-24 | Temperature Sensors 15 Calibration | Current calibration offset values for each of the five probes: supply, return, USDA #1, #2, and #3. These values are entered via the interrogation program. |
| dC25 | Future Expansion | This code is for future expansion, and is not in use at this time. |
| dC26,27 | S/N, Left 4, Right 4 | The DataCORDER serial number consists of eight characters. Function code dC26 contains the first four characters. Function code dC27 contains the last four characters. (This serial number is the same as the Controller serial number) |
| dC28 | Minimum Days Left | An approximation of the number of logging days remaining until the Data CORDER starts to overwrite the existing data. |
| dC29 | Days Stored | Number of days of data that are currently stored in the DataCORDER. |
| dC30 | Date of last Trip start | The date when a Trip Start was initiated by the user. In addition, if the system goes without power for seven continuous days or longer, a trip start will automatically be generated on the next AC power up. |
| dC31 | Battery Test | Shows the current status of the optional battery pack. PASS: Battery pack is fully charged. FAIL: Battery pack voltage is low. |
| dC32 | Time: Hour, Minute | Current time on the real-time clock (RTC) in the DataCORDER. |
| dC33 | Date: Month, Day | Current date (month and day) on the RTC in the DataCORDER. |
| dC34 | Date: Year | Current year on the RTC in the DataCORDER. |
| dC35 | Cargo Probe 4 Calibration | Current calibration value for the Cargo Probe. This value is an input via the interrogation program. |

Table 4–9 DataCORDER Pre-Trip Result Records

| Test No. | TITLE | DATA |
|-----------------|--|---|
| 1-0 | Heater On | Pass/Fail/Skip Result, Change in current for Phase A, B and C |
| 1-1 | Heater Off | Pass/Fail/Skip Result, Change in currents for Phase A, B and C |
| 2-0 | Condenser Fan On | Pass/Fail/Skip Result, Water pressure switch (WPS) - Open/Closed, Change in currents for Phase A, B and C |
| 2-1 | Condenser Fan Off | Pass/Fail/Skip Result, Change in currents for Phase A, B and C |
| 3-0 | Low Speed Evaporator Fan On | Pass/Fail/Skip Result, Change in currents for Phase A, B and C |
| 3-1 | Low Speed Evaporator Fan Off | Pass/Fail/Skip Result, Change in currents for Phase A, B and C |
| 4-0 | High Speed Evaporator Fan On | Pass/Fail/Skip Result, Change in currents for Phase A, B and C |
| 4-1 | High Speed Evaporator Fan Off | Pass/Fail/Skip Result, Change in currents for Phase A, B and C |
| 5-0 | Supply/Return Probe Test | Pass/Fail/Skip Result, STS, RTS, SRS and RRS |
| 5-1 | Secondary Supply Probe Test | Pass/Fail/Skip Result |
| 5-2 | Secondary Return Probe Test | Pass/Fail/Skip Result |
| 6-0 | Compressor On | Pass/Fail/Skip Result, Change in currents for Phase A, B and C |
| 6-1 | Not Applicable | Not Used |
| 6-2 | Suction Modulation Valve Open and Closed | Pass/Fail/Skip Result, Is current or pressure limit in effect (Y,N) |
| 6-4 | Not Applicable | Not Used |
| 6-5 | Not Applicable | Not Used |
| 7-0 | High Pressure Switch Closed | Pass/Fail/Skip Result, AMBS, DPT or CPT (if equipped) Input values that component opens |
| 7-1 | High Pressure Switch Open | Pass/Fail/Skip Result, STS, DPT or CPT (if equipped) Input values that component closes |
| 8-0 | Perishable Heat | Pass/Fail/Skip Result, STS, time it takes to heat to 16°C (60°F) |
| 8-1 | Perishable Pull Down | Pass/Fail/Skip Result, STS, time it takes to pull down to 0°C (32°F) |
| 8-2 | Perishable Maintain | Pass/Fail/Skip Result, Averaged DataCORDER supply temperature (SRS) over last recording interval. |
| 9-0 | Defrost Test | Pass/Fail/Skip Result, DTS reading at end of test, line voltage, line frequency, time in defrost. |
| 10-0 | Frozen Mode Setup | Pass/Fail/Skip Result, STS, time unit is in heat. |
| 10-1 | Frozen Mode Pull Down | Pass/Fail/Skip Result, STS, time to pull down unit to 17.8°C (0°F). |
| 10-2 | Frozen Mode Maintain | Pass/Fail/Skip Result, Averaged DataCORDER return temperature (RRS) over last recording interval. |

Table 4–10 DataCORDER Alarm Indications

| To Access: Press ALT. MODE key then ALARM LIST key | | |
|---|--|--|
| Code No. | TITLE | DESCRIPTION |
| dAL70 | Recorder Supply Temperature Out of Range | The supply recorder sensor reading is outside of the range of 50 to 70°C (58°F to +158°F) or, the probe check logic has determined there is a fault with this sensor. NOTE The P5 PreTrip test must be run to inactivate the alarm. |
| dAL71 | Recorder Return Temperature Out of Range | The return recorder sensor reading is outside of the range of 50 to 70°C (58°F to +158°F) or, the probe check logic has determined there is a fault with this sensor. NOTE The P5 PreTrip test must be run to inactivate the alarm. |
| dAL7274 | USDA Temperatures 1, 2, 3 Out of Range | The USDA probe temperature reading is sensed outside of 50 to 70°C (58 to 158°F) range. |
| dAL75 | Cargo Probe 4 Out of Range | The cargo probe temperature reading is outside of 50 to 70°C (58 to 158°F) range. |
| dAL76, 77 | Future Expansion | These alarms are for future expansion, and are not in use at this time. |
| dAL7885 | Network Data Point 1 - 8 Out of Range | The network data point is outside of its specified range. The DataCORDER is configured by default to record the supply and return recorder sensors. The DataCORDER may be configured to record up to 8 additional network data points. An alarm number (AL78 to AL85) is assigned to each configured point. When an alarm occurs, the DataCORDER must be interrogated to identify the data point assigned. When a humidity sensor is installed, it is usually assigned to AL78. |
| dAL86 | RTC Battery Low | The real time clock (RTC) backup battery is too low to adequately maintain the RTC reading. A real time clock failure is critical to the operation of the unit. If this alarm occurs, replace the RTC battery at the next available opportunity. After replacing the battery the following actions are required: Update the RTC setting Update the unit's software configuration Update the operational software Update all user selectable function code settings (defrost, setpoint, etc) |
| dAL87 | RTC Failure | An invalid time has been detected. Either the DataCORDER run time hour and minute have not changed at the start of the hour, or the real time clock (RTC) time has gained or lost more than 2 minutes in the hour. This situation may be corrected by cycling the power, setting the clock or meeting the above criteria for an hour. |
| dAL88 | DataCORDER EEPROM Failure | A write of critical DataCORDER information to the EEPROM has failed. |
| dAL89 | Flash Memory Error | An error has been detected in the process of writing daily data to the nonvolatile FLASH memory. |
| dAL90 | Future Expansion | This alarm is for future expansion, and is not in use at this time. |
| dAL91 | Alarm List Full | The DataCORDER alarm queue is determined to be full (eight alarms). |

SECTION 5 OPERATION

5.1 INSPECTION (BEFORE LOADING)

WARNING

Beware of unannounced starting of the evaporator and condenser fans. The unit may cycle the fans and compressor unexpectedly as control requirements dictate.

- a. If container is empty, check inside for the following:
 1. Check channels or “T” bar floor for cleanliness. Channels must be free of debris for proper air circulation.
 2. Check container panels, insulation, and door seals for damage. Make permanent or temporary repairs.
 3. Visually check evaporator fan motor mounting bolts for proper securement (refer to [Section 7.15](#)).
 4. Check for visible corrosion on the evaporator stator and fan deck (refer to [Section 7.15](#)).
 5. Check for dirt or grease on evaporator fan or fan deck and clean if necessary.
 6. Check evaporator coil for cleanliness or obstructions. Wash with fresh water (Refer to [Section 7.13](#)).
 7. Check defrost drain pans and drain lines for obstructions and clear if necessary. Wash with fresh water.
 8. Check panels on refrigeration unit for loose bolts and condition of panels. Make sure T.I.R. devices are in place on access panels.
- b. Check condenser coil for cleanliness. Wash with fresh water (Refer to [Section 7.10](#)).
- c. Open control box door. Check for loose electrical connections or hardware.
- d. Check color of moisture-liquid indicator.
- e. Check oil level in compressor sight glass (if applicable).

5.2 CONNECT POWER

WARNING

Do not attempt to remove power plug(s) before turning OFF start-stop switch (ST), unit circuit breaker(s) and external power source.

WARNING

Make sure the power plugs are clean and dry before connecting to power receptacle.

5.2.1 Connection To 380/460 VAC Power

1. Make sure start-stop switch (ST on control panel) and circuit breaker (CB-1 in the control box) are in position “O” (OFF).
2. Plug the 460VAC (yellow) cable into a de-energized 380/460VAC, 3-phase power source. Energize the power source. Place circuit breaker (CB-1) in position “I” (ON). Close and secure control box door.

5.2.2 Connection to 190/230VAC Power (option)

An autotransformer ([Figure 5.1](#)) is required to allow operation on nominal 230 volt power. It is fitted with a 230VAC cable and a receptacle to accept the standard 460VAC power plug. The 230 volt cable is black in color while the 460 volt cable is yellow. The transformer may also be equipped with a circuit breaker (CB-2). The transformer is a step-up transformer that will provide 380/460VAC, 3-phase, 50/60 hertz power to the unit when the 230VAC power cable is connected to a 190/230VAC, 3-phase power source.

1. Make sure that the start-stop switch (ST, on control panel) and circuit breakers CB-1 (in the control box and CB-2 (on the transformer) are in position “O” (OFF). Plug in and lock the 460VAC power plug at the receptacle on the transformer.
2. Plug the 230VAC (black) cable into a de-energized 190/230VAC, 3-phase power source. Energize the power source. Set circuit breakers CB-1 and CB2 to position “I” (ON). Close and secure control box door.

Figure 5.1 Autotransformer

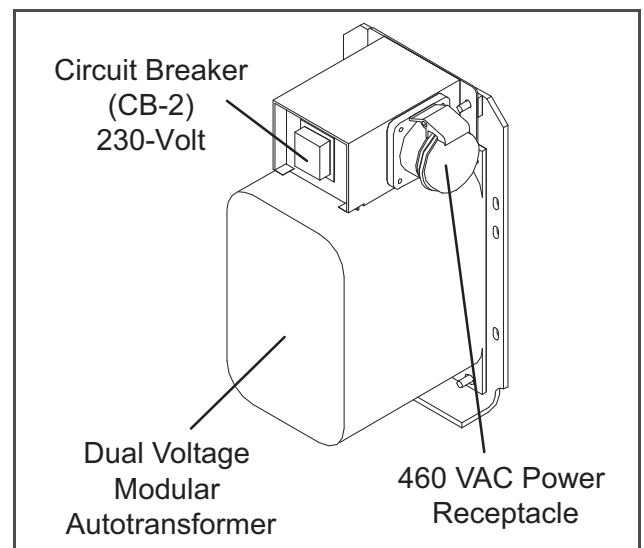

5.3 ADJUST FRESH AIR MAKEUP VENT

The purpose of the fresh air makeup vent is to provide ventilation for commodities that require fresh air circulation. The vent must be closed when transporting frozen foods.

Air exchange depends on static pressure differential, which will vary depending on the container and how the container is loaded.

Units may be equipped with a vent position sensor (VPS). The VPS determines the position of the fresh air vent (upper or lower, as equipped) and sends data to the controller display.

5.3.1 Upper Fresh Air Makeup Vent

Two slots and a stop are designed into the Upper Fresh Air disc for air flow adjustments. The first slot allows for a 0 to 30% air flow; the second slot allows for a 30 to 100% air flow.

To adjust the percentage of air flow, loosen the wing nut and rotate the disc until the desired percentage of air flow matches with the arrow. Tighten the wing nut.

To clear the gap between the slots, loosen the wing nut until the disc clears the stop.

Figure 5.2 gives air exchange values for an empty container. Higher values can be expected for a fully loaded container.

Figure 5.2 Make Up Air Flow Chart

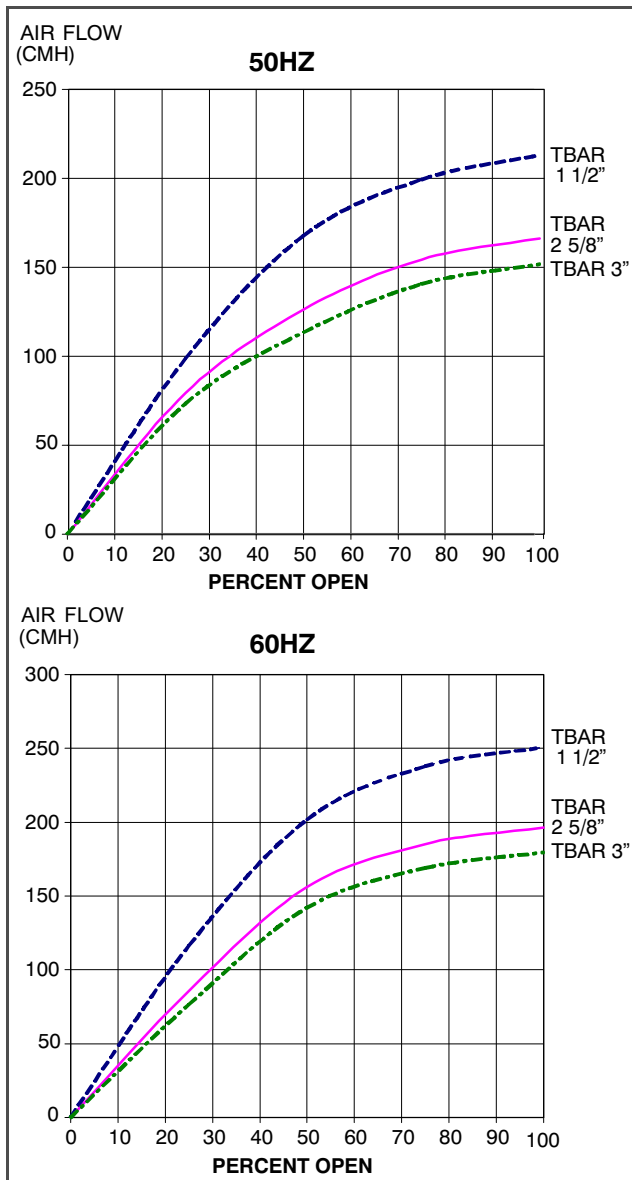

5.3.2 Vent Position Sensor

The VPS allows the user to determine position of the fresh air vent via Cd45. This function code is accessible via the code select key.

The vent position will display for 30 seconds whenever motion corresponding to 5CMH (3CFM) or greater is detected. It will scroll in intervals of 5CMH (3CFM). Scrolling to Cd45 will display the Fresh Air Vent Position.

The position of the vent will be recorded in the DataCORDER whenever the unit is running under AC power and any of the following:

- Trip start
- On every power cycle
- Midnight
- Manual change greater than 5 CMH (3 CFM) and remains in that position for at least four minutes

NOTE

The user has four minutes to make necessary adjustments to the vent setting. This time calculation begins on the initial movement of the sensor. The vent can be moved to any position within the four minutes. On completion of the first four minutes, the vent is required to remain stable for the next four minutes. If vent position changes are detected during the four minute stability period, an alarm will be generated. This provides the user with the ability to change the vent setting without generating multiple events in the DataCORDER.

5.4 EAUTOFRESH OPERATION

The eAutoFresh system allows the opening and closing of the mechanical air vent slide. The opening and closing of the slide is determined by the mode selected through Cd43.

The modes of operation are OFF, USER, TEST, DELAY, and GASLIMIT. Each mode of operation has submenus with selectable parameters. Not all parameters are available in each submenu.

Upon power up, the controller will fully close the eAutoFresh air vent. Nine seconds after power up, the controller will check if there is a carbon dioxide (CO₂) sensor connected. When a CO₂ sensor is detected, the controller will enable access to the Gas Limit mode of operation. If no sensor is detected, the only modes of operation available will be Test, User, and Delay. The controller will then resume operation in the last mode of operation before power interruption.

5.4.1 eAutoFresh Pre-Trip Inspection

Pre-trip testing of the eAutoFresh system is performed during Pre-Trip test P0. Operation of the system may be observed during this test.

Upon initiation of Pre-Trip P0, the current state will be saved and the vent will fully close. This will be followed by two sequences of opening to 100% and returning to the closed position. No other eAutoFresh mode of operation will be available until the two cycles of opening and closing have completed. Upon termination of the test, the vent will open to the previous state and operation will return to the previous mode.

If the last mode was gASLM, the vent will open to the preset FLO setting, the controller will start taking new readings and control based on those readings.

5.4.2 eAutoFresh Start-Up Procedure

To start the system, do the following:

- Press the "CODE SELECT" key (see [Figure 4.2](#)).
- Press the "UP or DOWN" arrow key until "Cd43" is displayed, then press "ENTER".
- Press the "UP or DOWN" arrow key to access the desired mode of operation. When the mode operation is displayed press the enter key to access the submenu parameters.

5.4.3 eAutoFresh Modes of Operation

NOTE

When setting any mode of operation, complete the entire process to ensure all parameters are set.

a. OFF

A setting of OFF will disable all automatic venting operations. The eAutoFresh vent will be driven fully closed and the eAutoFresh opening set to 0 CMH in Cd44. This is the default mode whenever a frozen mode of operation has been selected. When the frozen set point is selected, the current eAutoFresh setting is saved. The vent position will restore when a perishable set point is selected.

b. USER

The USER mode provides ventilation for commodities that require fresh air circulation. The flow rate can be accessed through the submenu if a perishable set point has been selected. To set the flow rate, press the ENTER key to activate the selection mode. When FLO appears in the left hand window, use the UP or DOWN arrow key to scroll to the desired opening. The range is from 0 to 220CM (0 to 129CF) in increments of 5. Press the ENTER key to set the value and begin operation.

c. TEST

TEST mode allows the operator to test the movement of the mechanical slide air vent and calibrate the CO₂ sensor.

tEst – When "tEst" appears in the left window, press the ENTER key to begin the test. The eAutoFresh slide will open fully and then return to the closed position. The test may be observed by the operator to ensure proper operation of the vent. After completion of the TEST, the unit will return to the previous mode of operation.

NOTE

It is recommended that the calibration procedure only be performed during Pre-trip or when the container has been fully vented.

CAL will attempt to calibrate the carbon dioxide sensor. When "CAL" mode is selected the display will flash "CAL". The operator is to hold the "ENTER" key for 5 seconds. The display will stop flashing and read "CAL" for 5 seconds. The microprocessor will read the CO₂ value, and then compare that value to a known zero value. If the sensor is within the calibration parameter range, the microprocessor will determine the appropriate offset for the sensor. If the sensor is outside of this range, for example if the container is loaded or has a high level of CO₂, the controller will flash "NOCAL" for 5 seconds then revert to the previous mode of operation.

d. DELAY

In DELAY mode, the operation of the eAutoFresh system will be delayed for a set amount of time. This allows time for the cargo to reach set point. In DELAY mode, the eAutoFresh vent will open to the stored (FLO) value when the return air temperature sensor (RTS) is at or below set point plus the return offset value (rtn) or the delay time (tIM), whichever comes first. The eAutoFresh vent will be fully closed when return air temperature sensor is greater than the set point plus the offset temperature (rtn).

To set the unit in Delay mode, scroll until "DELAY" appears in the left window, press the ENTER key to activate the submenu. The first selection is the amount of time (tIM) for the delay. Select the amount of time for the delay by using the UP and DOWN arrow keys. The range is from 1 to 72 hours in 1 hour increments. Press the ENTER key to set the value and move to the FLO rate. Use the UP or DOWN arrow key to scroll to the desired FLO rate. The range is from 0 to 220CM (0 to 129CF) in increments of 5 and 3 respectively. Press the ENTER key to set the value and move to the return temperature offset. Use the UP or DOWN arrow key to scroll to the desired rtn rate. The range of offset is from 0.6°C to 2.8°C (1.0°F to 2.8°F) in 0.1 degree increments. Press the ENTER key to set the value and begin operation.

e. GAS LIMIT (gASLM)

In GAS LIMIT mode, access to the submenu is available provided a perishable set point has been selected, and a valid reading is detected from the carbon dioxide sensor. In "Gas limit" mode the microprocessor will monitor and limit the amount of carbon dioxide within the container by opening and closing the eAutoFresh vent. The vent will open to the (FLO) setting once the unit has completed initial temperature pull down or if the cargo temperature is within 5C of set point and the carbon dioxide level has reached the max limit or if the Oxygen level has reached the lower limit. After the first 15 minutes of the vent opening the controller will again evaluate the level of CO₂, and/or O₂ levels. If after the first 15 minutes the gas limit values are satisfied, the vent will close, if either gas limit has not been satisfied within 15 minutes the air exchange vent will open in 10 CMH increments every 15 minutes until both gas con-

centrations are satisfied. Once all limits are satisfied the vent will return to the closed position. If conditions are not met with the slide open 100% for 90 minutes AI29 will be activated.

To operate in Gas Limit mode, scroll until gASLM appears in the left window, press the ENTER key to activate the submenu. The first selection is the maximum carbon dioxide (CO2LM). Select the max level by using the UP and DOWN arrow keys.

The range is from 0 to 19% in 1% increments. Press the ENTER key to set the value and move to the minimum Oxygen level (O2LM). The range is from 2 to 20% in 1% increments. Press the ENTER key to set the value and move to the FLO rate. Use the UP or DOWN arrow key to scroll to the desired FLO rate. The range is from 0 to 220CM (0 to 129CF) in increments of 5 and 3 respectively. Press the ENTER key to set the value and begin operation.

Operational Parameters (Sub Menu Options):

FLO indicates the opening to which the slide will move based on the stored value in CMH (in increments of 5) or CFM depending on the selection of Cd46 (Airflow display units), Cd28 (Metric/Imperial) or the pressing of the deg C/F key. CFM is displayed as CF, CMH is displayed as CM.

tM is the time delay prior to the door opening. The time range is from 1 to 72 hrs in 1 hr increments.

CO2LM is the maximum level of CO₂ that is allowed for the cargo. The range is from 0% to 19% in 1% increments, the default setting is 10.

O2LM is the minimum level of O₂ that is allowed for the cargo. The range is from 2% to 20% in 1% increments, the default setting is 10.

Rtn is an offset value used to expand the return air temperature value to compensate for the fresh air entering the container. The allowable range is from 0.6°C to 2.8°C or 1.0°F to 5.0°F in 0.1 degree increments the default setting is 2.8°C (5°F).

5.5 CONNECT REMOTE MONITORING RECEPTACLE

If remote monitoring is required, connect remote monitor plug at the unit receptacle, see [Figure 3.5](#).

When the remote monitor plug is connected to the remote monitoring receptacle, the following remote circuits are energized:

| CIRCUIT | FUNCTION |
|----------------|---------------------------------|
| Sockets B to A | Energizes remote cool light |
| Sockets C to A | Energizes remote defrost light |
| Sockets D to A | Energizes remote in-range light |

5.6 STARTING AND STOPPING INSTRUCTIONS



WARNING

Make sure that the unit circuit breaker(s) (CB-1 & CB-2) and the START-STOP switch (ST) are in the “O” (OFF) position before connecting to any electrical power source.

5.6.1 Starting the Unit

- With power properly applied, the fresh air vent in proper position, place the START-STOP switch to “I” (ON), see [Figure 3.5](#).
- The Controller Function Codes for the container ID (Cd40), software version (Cd18) and unit model number (Cd20) will be displayed in sequence.
- Continue with Start Up Inspection (refer to [Section 5.7](#)).

5.6.2 Stopping the Unit

To stop the unit, place the START-STOP switch in position “O” (OFF).

5.7 START-UP INSPECTION

5.7.1 Physical Inspection

- Check rotation of condenser and evaporator fans.
- Check compressor oil level (refer to [Section 7.8.6](#)).

5.7.2 Check Controller Function Codes

Check and, if required, reset controller Function Codes (Cd27 through Cd39) in accordance with desired operating parameters (refer to [Section 4.2.2](#)).

5.7.3 Start Temperature Recorder

DataCORDER

- Check and, if required, set the DataCORDER Configuration in accordance with desired recording parameter. Refer to [Section 4.8.2](#).
- Enter a “Trip Start.” To enter a “Trip Start,” do the following:
 - Depress the ALT MODE key. When the left display shows, dC, depress the ENTER key.
 - Scroll to Code dC30.
 - Depress and hold the ENTER key for five seconds.
 - The “Trip Start” event will be entered in the DataCORDER.

5.7.4 Complete Inspection

Allow unit to run for five minutes to stabilize conditions and perform a pre-trip diagnosis in accordance with [Section 5.8](#).

5.8 PRE-TRIP DIAGNOSTICS

CAUTION

Pre-trip inspection should not be performed with critical temperature cargoes in the container.

CAUTION

When Pre-Trip key is pressed, economy, dehumidification and bulb mode will be deactivated. At the completion of Pre-Trip activity, economy, dehumidification and bulb mode must be reactivated.

Pre-Trip diagnostics provides automatic testing of the unit components using internal measurements and comparison logic. The program will provide a "PASS" or "FAIL" display to indicate test results.

The testing begins with access to a Pre-trip selection menu. The user may have the option of selecting one of three automatic tests.

These tests will automatically perform a series of individual Pre-trip tests. The user may also scroll down to select any of the individual tests.

When only the short sequence is configured, it will appear as "AUtO" in the display. Otherwise "AUtO1" will indicate the short sequence and "AUtO2" will indicate the long sequence. The test short sequence will run tests P0 through P6. The long test sequence will run tests P0 through P10.

A detailed description of the Pre-trip test codes is listed in [Table 4-7](#). If no selection is made, the Pre-trip menu selection process will terminate automatically. However, dehumidification and bulb mode must be reactivated manually if required.

Scrolling down to the "rSLts" code and pressing ENTER will allow the user to scroll through the results of the last pre-trip testing run. If no pre-testing has been run (or an individual test has not been run) since the unit was powered up, "----" will be displayed.

To start a Pre-trip test, do the following:

NOTE

1. Prior to starting a Pre-trip test, verify that unit voltage (Cd07) is within tolerance and unit amperage draw (Cd04, Cd05, Cd06) are within expected limits. Otherwise, tests may fail incorrectly.
2. All alarms must be rectified and cleared before starting tests.

3. Pre-trip may also be initiated via communications. The operation is the same as for the keypad initiation described below except that should a test fail, the Pre-trip mode will automatically terminate. When initiated via communications, a Pre-trip test may not be interrupted with an arrow key, but the Pre-trip test can be terminated with the PRE-TRIP key.

- a. Press the PRE-TRIP key to access the Pre-trip test selection menu.
- b. TO RUN AN AUTOMATIC TEST: Scroll through the selections by pressing the UP ARROW or DOWN ARROW keys to display AUTO, AUTO 2 or AUTO 3 as desired and then press the ENTER key.
 1. The unit will execute the series of tests without any need for direct user interface. These tests vary in length, depending on the component under test.
 2. While tests are running, "P#-#" will appear on the left display, where the #'s indicate the test number and sub-test. The right display will show a countdown time in minutes and seconds, indicating the amount of time remaining in the test.

CAUTION

When a failure occurs during automatic testing the unit will suspend operation awaiting operator intervention.

When an automatic test fails, it will be repeated once. A repeated test failure will cause "FAIL" to be shown on the right display, with the corresponding test number to the left.

The user may then press the DOWN ARROW to repeat the test, the UP ARROW to skip to the next test or the PRE-TRIP key to terminate testing. The unit will wait indefinitely until the user manually enters a command.

CAUTION

When Pre-Trip test Auto 2 runs to completion without being interrupted, the unit will terminate pre-trip and display "Auto 2" "end." The unit will suspend operation until the user depresses the ENTER key!

When an Auto test runs to completion without a failure, the unit will exit the Pre-trip mode and return to normal control operation.

If configuration variable CnF42 is set to IN, a Data-CORDER trip start will be entered. If CnF42 is set to OUT, the trip start will not be entered. However, dehumidification and bulb mode must be reactivated manually if required.

c. TO RUN AN INDIVIDUAL TEST: Scroll through the selections by pressing the UP ARROW or DOWN ARROW keys to display an individual test code. Pressing ENTER when the desired test code is displayed.

1. Individually selected tests, other than the LED/Display test, will perform the operations necessary to verify the operation of the component. At the conclusion, PASS or FAIL will be displayed.

This message will remain displayed for up to three minutes, during which time a user may select another test. If the three minute time period expires, the unit will terminate pre-trip and return to control mode operation.

2. While the tests are being executed, the user may terminate the pre-trip diagnostics by pressing and holding the PRE-TRIP key.

The unit will then resume normal operation. If the user decides to terminate a test but remain at the test selection menu, the user may press the UP ARROW key. When this is done all test outputs will be de-energized and the test selection menu will be displayed.

3. During Pre-trip testing, current limiting and pressure limiting are both active, except during P-7 (High Pressure Switch Testing) when pressure limiting is turned off.

d. Pre-Trip Test Results

At the end of the pre-trip test selection menu, the message "P," "rSLts" (pre-trip results) will be displayed. Pressing the ENTER key will allow the user to see the results for all subtests (i.e., 1-0, 1-1, etc).

The results will be displayed as "PASS" or "FAIL" for all the tests run to completion since power up. If a test has not been run since power up, "-----" will be displayed.

Once all pre-test activity is completed, dehumidification and bulb mode must be reactivated manually if required.

5.9 PROBE DIAGNOSTICS

A complete temperature probe check is performed during the P5 Pre-trip test. A probe check is also run at the end of a defrost cycle; the defrost light will remain on during this period. If supply probes are within limits and return probes are within limits, the unit will return to normal operation. During normal operation, the controller continuously monitors and compares adjacent temperature probe readings.

The probe check procedure consists of running the evaporator fans for up to eight minutes in order to compare the readings from the adjacent temperature probes. If a significant difference in temperature readings is detected between probes, a defrost cycle, followed by another probe check may be initiated. Any continued disagreement between probes will prompt the controller to invalidate the failed temperature probe, and the backup probe will be used for temperature control.

In Perishable Mode, both pairs of supply and return probes are monitored for probe disagreement. Probe disagreement is considered a difference of 0.5°C (0.9°F) or greater between the supply air sensors and/or a difference of 2.0°C (3.6°F) between the return air sensors. Probe disagreement found in either pair can trigger a defrost probe check.

In Frozen Mode, only the controlling probes are considered. Disagreement of the controlling probes can trigger a defrost probe check, which will occur when the difference between the sensors is greater than 2.0°C (3.6°F). Normally, the controlling probes are the return probes but if both return probes are invalidated, the supply probes are used for control purposes. Probe disagreement of the non-controlling probe pair will not trigger a defrost probe check.

If, after the defrost probe check, the supply probes agree and return probes agree, all supply and return sensors are considered valid and the unit returns to normal control.

In the Case of Probe Disagreement:

If the supply probes disagree and the return probes agree, the controller will invalidate the worst supply probe. If the probe check is run as part of Pre-trip P-5, an alarm will be triggered for the invalidated probe. If it is a run time defrost probe check, the invalidated probe will be passed over and no alarm will be triggered. However, if the best supply probe is greater than 1.2°C (2.2°F) difference with respect to its return probes, the best supply probe is also invalidated. If unit is in Perishable Mode, a probe alarm will be triggered for both supply probes.

If the supply probes agree and the return probes disagree, invalidate the worst return probe. If the probe check is being run as part of Pre-trip P-5, an alarm will be triggered for the invalidated probe. If it is a run time defrost probe check, the invalidated probe will be passed over and no alarm will be necessary. If the best return probe is greater than 1.2°C (2.2°F) difference with respect to its supply probes, then the best return probe is also invalidated. If the unit is in perishable mode, a probe alarm will be triggered for both return probes.

5.10 EMERGENCY BYPASS OPERATION (OPTION)

Operation by the refrigeration controller may be overridden by use of the EMERGENCY BYPASS switch. The EMERGENCY BYPASS switch functions to bypass the controller in the event of controller failure.

To place the unit in the emergency bypass mode, cut the wire tie installed at the switch mounting and place the EMERGENCY BYPASS switch in the BYPASS position. This will in turn activate the Emergency Bypass System (EBS) control module.

To operate the fans only, the MODE switch must be in the FANS ONLY position and the EMERGENCY BYPASS Switch must be in the ON position.

The EBS module uses the system safety devices (high pressure switch, motor internal protectors, and heat termination thermostat) to protect the system while in Emergency Bypass Mode.



The unit will remain in the full cooling mode as long as the emergency bypass switch is in the BYPASS position and the MODE SWITCH is in the FULL COOL position.

If the cargo is at risk of being damaged by low temperatures, the operator must monitor container temperature and manually cycle operation as required to maintain temperature within required limits.

In the ON position the EBS will be enabled. With the MODE SWITCH in the FULL COOL MODE. The following will occur simultaneously:

1. The EBS switch will enable EBS input.
2. The phase detection circuit will detect the phase rotation and close to provide power to the compressor contactor.
3. The condenser fan contact will close to energize the condenser contactor and provide power to the condenser fan motor.
4. The evaporator fan contact will close to energize the high speed evaporator contactor and provide power to the evaporator fan motor.
5. The EBS electronic module will open the SMV to 100%.

To return the unit to normal operation, place the EBS switch in the NORMAL OPERATION position. When emergency operation is no longer required, re-install the wire tie at the switch mounting.

SECTION 6

TROUBLESHOOTING

6.1 UNIT WILL NOT START OR STARTS THEN STOPS

| Condition | Possible Cause | Remedy/Reference Section |
|-------------------------------------|--|--------------------------|
| No power to unit | External power source OFF | Turn on |
| | Start-Stop switch OFF or defective | Check |
| | Circuit breaker tripped or OFF | Check |
| | Autotransformer not connected | 5.2.2 |
| Loss of control power | Circuit breaker OFF or defective | Check |
| | Control transformer defective | Replace |
| | Fuses (F3A, F3B) blown | Check |
| | Start-Stop switch OFF or defective | Check |
| Component(s) Not Operating | Evaporator fan motor internal protector open | 7.14 |
| | Condenser fan motor internal protector open | 7.11 |
| | Compressor internal protector open | 7.8 |
| | High pressure switch open | 6.7 |
| | Heat termination thermostat open | Replace |
| Compressor hums, but does not start | Low line voltage | Check |
| | Single phasing | Check |
| | Shorted or grounded motor windings | 7.8 |
| | Compressor seized | 7.8 |

6.2 UNIT OPERATES LONG OR CONTINUOUSLY LONG IN COOLING

| Condition | Possible Cause | Remedy/Reference Section |
|--------------------------------------|---|--------------------------|
| Container | Hot load (Failure to Pre-cool) | Normal |
| | Defective box insulation or air leak | Repair |
| Refrigeration System | Shortage of refrigerant | 7.7.1 |
| | Evaporator coil covered with ice | 6.6 |
| | Evaporator coil plugged with debris | 7.13 |
| | Evaporator fan(s) rotating backwards | 7.13/7.14 |
| | Defective evaporator fan motor | 7.14 |
| | Air bypass around evaporator coil | Check |
| | Controller set too low | Reset |
| | Compressor service valves or liquid line shutoff valve partially closed | Open valves completely |
| | Dirty condenser | 7.10.1 |
| | Compressor worn | 7.8 |
| | Current limit (function code Cd32) set to wrong value | 4.4.3 |
| Suction modulation valve malfunction | 7.17 | |

6.3 UNIT RUNS BUT HAS INSUFFICIENT COOLING

| Condition | Possible Cause | Remedy/Reference Section |
|----------------------|---|--------------------------|
| Compressor | Compressor valves defective | 7.8 |
| Refrigeration System | Abnormal pressures | 6.7 |
| | Controller malfunction | 6.9 |
| | Evaporator fan or motor defective | 7.14 |
| | Suction modulation valve malfunction | 7.17 |
| | Condenser Pressure Transducer defective | Check |
| | Shortage of refrigerant | 7.7.1 |

6.4 UNIT WILL NOT HEAT OR HAS INSUFFICIENT HEATING

| Condition | Possible Cause | Remedy/Reference Section |
|---|---|---------------------------|
| No operation of any kind | Start-Stop switch OFF or defective | Check |
| | Circuit breaker OFF or defective | Check |
| | External power source OFF | Turn ON |
| No control power | Circuit breaker or fuse defective | Replace |
| | Control Transformer defective | Replace |
| | Evaporator fan internal motor protector open | 7.14 |
| | Heat relay defective | Check |
| | Heater termination switch open | 7.13 |
| Unit will not heat or has insufficient heat | Heater(s) defective | 7.13 |
| | Heater contactor or coil defective | Replace |
| | Evaporator fan motor(s) defective or rotating backwards | 7.13/7.14 |
| | Evaporator fan motor contactor defective | Replace |
| | Controller malfunction | 6.9 |
| | Defective wiring | Replace |
| | Loose terminal connections | Tighten |
| | Low line voltage | 3.3 |

6.5 UNIT WILL NOT TERMINATE HEATING

| Condition | Possible Cause | Remedy/Reference Section |
|----------------------------|--|--------------------------|
| Unit fails to stop heating | Controller improperly set | Reset |
| | Controller malfunction | 6.9 |
| | Heater termination thermostat remains closed along with the heat relay | 7.13 |

6.6 UNIT WILL NOT DEFROST PROPERLY

| Condition | Possible Cause | Remedy/Reference Section |
|---|--|---------------------------|
| Will not initiate defrost automatically | Defrost timer malfunction (Cd27) | Table 4–5 |
| | Loose terminal connections | Tighten |
| | Defective wiring | Replace |
| | Defrost temperature sensor defective or heat termination thermostat open | Replace |
| | Heater contactor or coil defective | Replace |
| Will not initiate defrost manually | Manual defrost switch defective | Replace |
| | Defrost temperature sensor open | 7.21 |
| Initiates but relay (DR) drops out | Low line voltage | 3.3 |
| Initiates but does not defrost | Heater contactor or coil defective | Replace |
| | Heater(s) burned out | 7.13 |
| Frequent defrost | Wet load | Normal |

6.7 ABNORMAL PRESSURES (COOLING)

| Condition | Possible Cause | Remedy/Reference Section |
|---|---|--------------------------|
| High discharge pressure | Condenser coil dirty | 7.10.1 |
| | Condenser fan rotating backwards | 7.11 |
| | Condenser fan inoperative | 7.11 |
| | Refrigerant overcharge or noncondensibles | 7.7.1 |
| | Discharge service valve partially closed | Open |
| | Suction modulation valve malfunction | 7.17 |
| Low suction pressure | Suction service valve partially closed | Open |
| | Filter-drier partially plugged | 7.12 |
| | Low refrigerant charge | 7.7.1 |
| | Expansion valve defective | 7.16 |
| | No evaporator air flow or restricted air flow | 7.13 |
| | Excessive frost on evaporator coil | 6.6 |
| | Evaporator fan(s) rotating backwards | 7.14.3 |
| | Suction modulation valve malfunction | 7.17 |
| Suction and discharge pressures tend to equalize when unit is operating | Heat exchanger defective | Replace |
| | Compressor valves defective | 7.8 |
| | Compressor cycling/stopped | Check |

6.8 ABNORMAL NOISE OR VIBRATIONS

| Condition | Possible Cause | Remedy/Reference Section |
|-----------------------------|---------------------------------|---------------------------|
| Compressor | Loose mounting bolts | Tighten |
| | Worn bearings | 7.8 |
| | Worn or broken valves | 7.8 |
| | Liquid slugging | 7.16 |
| | Insufficient oil | 7.8.6 |
| Condenser or Evaporator Fan | Bent, loose or striking venturi | Check |
| | Worn motor bearings | 7.11/7.14 |
| | Bent motor shaft | 7.11/7.14 |

6.9 MICROPROCESSOR MALFUNCTION

| Condition | Possible Cause | Remedy/Reference Section |
|------------------|--|--------------------------|
| Will not control | Defective Sensor | 7.21 |
| | Defective wiring | Check |
| | Fuse (F1, F2) blown | Replace |
| | Stepper motor suction modulation valve circuit malfunction | 7.17 |

6.10 NO EVAPORATOR AIR FLOW OR RESTRICTED AIR FLOW

| Condition | Possible Cause | Remedy/Reference Section |
|-----------------------------------|--|--------------------------|
| Evaporator coil blocked | Frost on coil | 6.6 |
| | Dirty coil | 7.13 |
| No or partial evaporator air flow | Evaporator fan motor internal protector open | 7.14 |
| | Evaporator fan motor(s) defective | 7.14 |
| | Evaporator fan(s) loose or defective | 7.14 |
| | Evaporator fan contactor defective | Replace |

6.11 EAUTOFRESH NOT OPERATING

| Condition | Possible Cause | Remedy/Reference Section |
|--|--|--------------------------|
| Vent not opening | Unit not Configured for eAutoFresh Operation | No action |
| | Cd43 in Off mode | 5.4.2 |
| | Wiring disconnected | Check wiring |
| | Stepper drive defective | 7.23.2 |
| | Stepper motor defective | 7.23.2 |
| | Unit operating in frozen mode | 5.4.3 |
| Gas Limit mode unavailable | Check CO ₂ sensor | 5.4.3 |
| | Wiring disconnected | Check wiring |
| | Unit operating in frozen mode | 5.4.3 |
| Unable to calibrate CO ₂ sensor | Enter Key not held for sufficient length of time | 5.4.3 |
| | CO ₂ outside of acceptable levels | Check |
| | Check CO ₂ sensor | 5.4.3 |
| Cd44 displays ----- | Unit not Configured for eAutoFresh Operation | No action |
| | Check CO ₂ sensor | 5.4.3 |

6.12 THERMOSTATIC EXPANSION VALVE MALFUNCTION

| Condition | Possible Cause | Remedy/Reference Section |
|--|---|--------------------------|
| Low suction pressure with high superheat | Low refrigerant charge | 7.7.1 |
| | External equalizer line plugged | Open |
| | Wax, oil or dirt plugging valve or orifice ice formation at valve seat | 7.16 |
| | Superheat too high | 7.7.1 |
| | Power assembly failure | 7.16 |
| | Loss of element/bulb charge | 7.16 |
| | Broken capillary | 7.16 |
| | Foreign material in valve | 7.16 |
| High suction pressure with low superheat | Superheat setting too low | 7.16 |
| | External equalizer line plugged ice holding valve open | Open |
| | Foreign material in valve | 7.16 |
| Liquid slugging in compressor | Pin and seat of expansion valve eroded or held open by foreign material | 7.16 |
| Fluctuating suction pressure | Improper bulb location or installation | 7.16 |
| | Low superheat setting | 7.16 |

6.13 AUTOTRANSFORMER MALFUNCTION

| Condition | Possible Cause | Remedy/Reference Section |
|---------------------|--|--------------------------|
| Unit will not start | Circuit breaker (CB1 or CB2) tripped | Check |
| | Autotransformer defective | 7.19 |
| | Power source not turned ON | Check |
| | 460 VAC power plug is not inserted into the receptacle | 5.2.2 |

SECTION 7

SERVICE

NOTE

Use a refrigerant recovery system whenever removing refrigerant. When working with refrigerants you must comply with all local government environmental laws. In the U.S.A., refer to EPA section 608.

WARNING

EXPLOSION HAZARD: Failure to follow this WARNING can result in death, serious personal injury and / or property damage.

Never use air or gas mixtures containing oxygen (O₂) for leak testing or operating the product.

Charge Only With R-134a: Refrigerant must conform to AHRI Standard 700 specification.

7.1 SECTION LAYOUT

Service procedures are provided in this section beginning with refrigeration system service, then refrigeration system component service, electrical system service, temperature recorder service and general service. Refer to the Table of Contents to locate specific topics.

7.2 MANIFOLD GAUGE SET

The manifold gauge set (see [Figure 7.1](#)) is used to determine system operating pressure, add refrigerant charge, and to equalize or evacuate the system.

Figure 7.1 Manifold Gauge Set

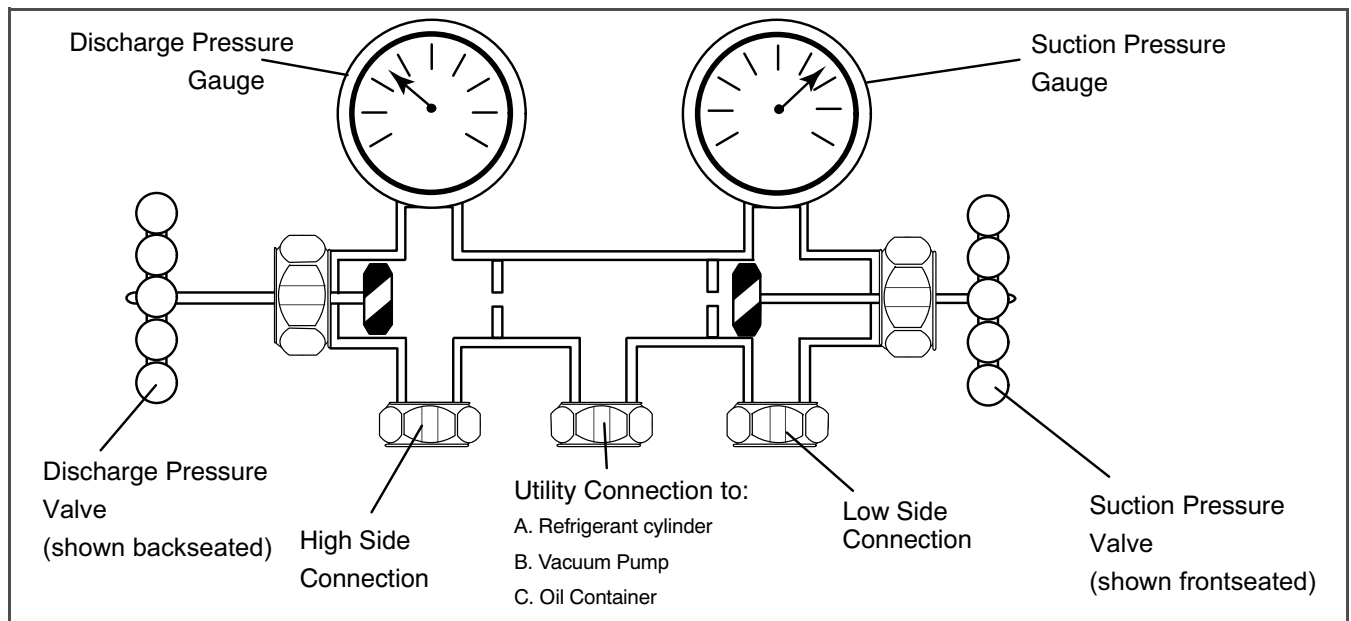

When the Suction Pressure Valve is frontseated (turned all the way in), the suction (low) pressure can be checked at the Suction Pressure Gauge.

When the Discharge Pressure Valve is frontseated, the discharge (high) pressure can be checked at the Discharge Pressure Gauge.

When both valves are backseated (all the way out), high pressure vapor will flow into the low side.

When the Suction Pressure Valve is open and the Discharge Pressure Valve is shut, the system can be charged through the Utility Connection. Oil can also be added to the system.

A R-134a manifold gauge/hose set with self-sealing hoses (see [Figure 7.2](#)) is required for service of the models covered within this manual. The manifold gauge/hose set is available from Carrier Transicold. (Carrier Transicold P/N 07-00294-00, which includes items 1 through 6, [Figure 7.2](#)).

If the manifold gauge/hose set is new or was exposed to the atmosphere, it will need to be evacuated to remove contaminants and air as follows:

1. Backseat (turn counterclockwise) both field service couplings (see [Figure 7.2](#)) and midseat both hand valves.
2. Connect the yellow hose to a vacuum pump and refrigerant 134a cylinder.
3. Evacuate to 10 inches of vacuum and then charge with R-134a to a slightly positive pressure of 0.1kg/cm² (1.0 psig).
4. Frontseat both manifold gauge set valves and disconnect from cylinder. The gauge set is now ready for use.

Figure 7.2 R-134a Manifold Gauge/Hose Set

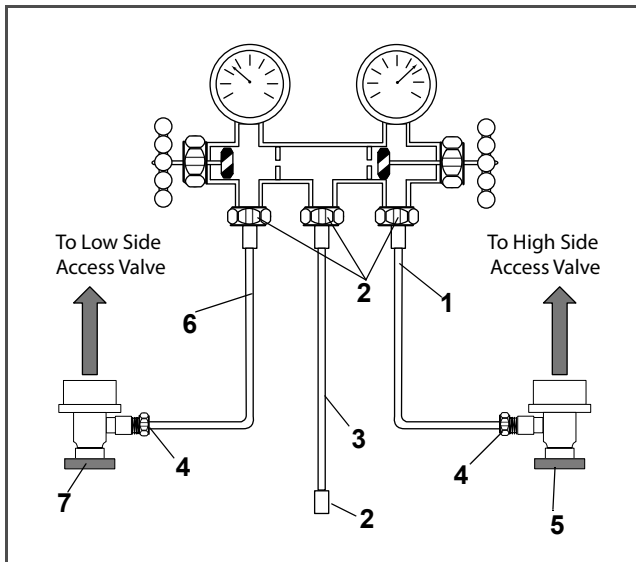

1. RED Refrigeration and/or Evacuation Hose (SAE J2196/R-134a)
2. Hose Fitting (0.5-16 Acme)
3. YELLOW Refrigeration and/or Evacuation Hose (SAE J2196/R-134a)
4. Hose Fitting with O-ring (M14 x 1.5)
5. High Side Field Service Coupling (Red Knob)
6. BLUE Refrigeration and/or Evacuation Hose (SAE J2196/R-134a)
7. Low Side Field Service Coupling (Blue Knob)

7.3 SERVICE VALVES

Compressor suction, compressor discharge, and liquid line service valves (see [Figure 7.3](#)) are provided with a double seat and a gauge connection, which enables servicing of the compressor and refrigerant lines.

Turning the valve stem clockwise (all the way forward) will frontseat the valve to close off the suction, discharge or liquid line and open the gauge port to the compressor or low side. Turning the stem counterclockwise (all the way out) will backseat the valve to open the connections and close off the port.

With the valve stem midway between frontseat and backseat, both of the service valve connections are open to the access valve path.

For example, the valve stem is first fully backseated when connecting a manifold gauge to measure pressure. Then, the valve is opened 1/4 to 1/2—turn to measure the pressure.

Figure 7.3 Service Valve

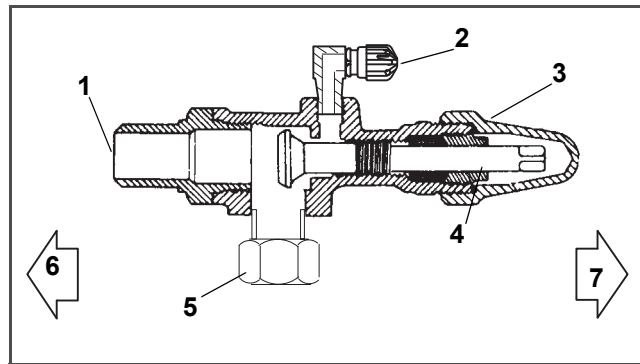

1. Line Connection
2. Access Valve
3. Stem Cap
4. Valve stem
5. Compressor or Filter Drier Inlet Connection
6. Valve (Frontseated)
7. Valve (Backseated)

Connection of the manifold gauge/hose set (see [Figure 7.4](#)) is dependent on the component being serviced. If only the compressor is being serviced, the high side coupling is connected to the discharge service valve.

For service of the low side (after pump down), the high side coupling is connected to the liquid line service valve. The center hose connection is brought to the tool being used (vacuum, tank, etc.).

Connecting the manifold gauge set:

- a. Remove service valve stem cap and make sure the valve is backseated.
- b. Remove service port cap (See [Figure 7.3](#)).
- c. Connect the high side field service coupling (see [Figure 7.2](#)) to the discharge or liquid line valve service valve port.
- d. Turn the high side field service coupling knob (red) clockwise, which will open the high side of the system to the gauge set.
- e. Connect the low side field service coupling to the suction service valve port.
- f. Turn the low side field service coupling knob (blue) clockwise, which will open the low side of the system to the gauge set.
- g. To read system pressures, slightly midseat the high side and suction service valves.

CAUTION

To prevent trapping liquid refrigerant in the manifold gauge set, be sure set is brought to suction pressure before disconnecting.

Removing the Manifold Gauge Set:

- a. While the compressor is still ON, backseat the high side service valve.
- b. Midseat both hand valves on the manifold gauge set and allow the pressure in the manifold gauge set to be drawn down to suction pressure. This returns any liquid that may be in the high side hose to the system.
- c. Backseat the suction service valve. Backseat both field service couplings and frontseat both manifold set valves. Remove the couplings from the service ports.
- d. Install both service valve stem caps and service port caps (finger-tight only).

7.4 PUMP THE UNIT DOWN

To service the filter-drier, moisture-liquid indicator, expansion valve, suction modulation valve, quench valve, or evaporator coil, pump the refrigerant into the high side as follows:

- a. Attach manifold gauge set to compressor service valves (refer to [Section 7.2](#)).
- b. Start the unit and run in a cooling mode for 10 to 15 minutes. Frontseat the liquid line service valve. Place start-stop switch in the OFF position when the suction reaches a positive pressure of 0.1kg/cm² (1.0psig).
- c. Frontseat the suction service valve. The refrigerant will be trapped between the compressor suction service valve and the liquid line valve.
- d. Before opening up any part of the system, a slight positive pressure should be indicated on the pressure gauge. If a vacuum is indicated, emit refrigerant by cracking the liquid line valve momentarily to build up a slight positive pressure.
- e. When opening up the refrigerant system, certain parts may frost. Allow the part to warm to ambient temperature before dismantling. This avoids internal condensation, which puts moisture in the system.
- f. After repairs have been made, be sure to perform a refrigerant leak check (refer to [Section 7.5](#)), and evacuate and dehydrate the low side (refer to [Section 7.6](#)).
- g. Check refrigerant charge (refer to [Section 7.7](#)).

7.5 REFRIGERANT LEAK CHECKING



WARNING

EXPLOSION HAZARD: Failure to follow this WARNING can result in death, serious personal injury and / or property damage.

Never use air or gas mixtures containing oxygen (O₂) for leak testing or operating the product.

Charge Only With R-134a: Refrigerant must conform to AHRI Standard 700 specification.

- a. The recommended procedure for finding leaks in a system is with a R-134a electronic leak detector. Testing joints with soapsuds is satisfactory only for locating large leaks.
- b. If the system is without refrigerant, charge the system with refrigerant 134a to build up pressure between 2.1 to 3.5kg/cm² (30 to 50psig). Remove refrigerant cylinder and leak-check all connections.

NOTE

Only refrigerant 134a should be used to pressurize the system. Any other gas or vapor will contaminate the system, which will require additional purging and evacuation of the system.

- c. If required, remove refrigerant using a refrigerant recovery system and repair any leaks.
- d. Evacuate and dehydrate the unit (refer to [Section 7.6](#)).
- e. Charge unit per [Section 7.7](#).

7.6 EVACUATION AND DEHYDRATION

7.6.1 General

Moisture is the deadly enemy of refrigeration systems. The presence of moisture in a refrigeration system can have many undesirable effects. The most common are copper plating, acid sludge formation, “freezing-up” of metering devices by free water, and formation of acids, resulting in metal corrosion.

7.6.2 Preparation

- a. Evacuate and dehydrate only after pressure leak test (refer to [Section 7.5](#)).
- b. Essential tools to properly evacuate and dehydrate any system include a vacuum pump (8m/hr = 5cfm volume displacement) and an electronic vacuum gauge. The pump is available from Carrier Transicold, P/N 07-00176-11. The micron gauge is P/N 07-00414-00.
- c. If possible, keep the ambient temperature above 15.6°C (60°F) to speed evaporation of moisture. If the ambient temperature is lower than 15.6°C (60°F), ice might form before moisture removal is complete. Heat lamps or alternate sources of heat may be used to raise the system temperature.
- d. Additional time may be saved during a complete system pump down by replacing the filter-drier with a section of copper tubing and the appropriate fittings. Installation of a new drier may be performed during the charging procedure.

Figure 7.4 Refrigeration System Service Connections

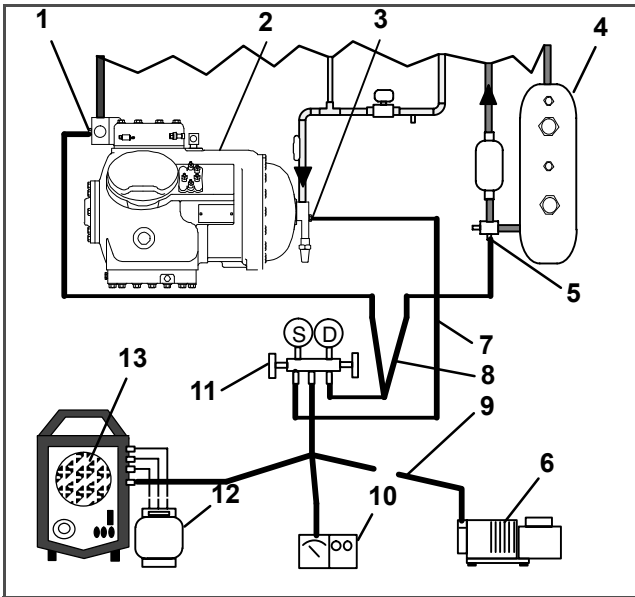

1. Discharge Service Valve
2. Compressor
3. Suction Service Valve
4. Receiver or Water Cooled Condenser
5. Liquid Service Valve
6. Vacuum Pump
7. Low Side Hose
8. Center Hose
9. High Side Hose
10. Electronic Vacuum Gauge
11. Manifold Gauge Set
12. Refrigerant Cylinder
13. Reclaimer

7.6.3 Complete System

- a. Remove all refrigerant using a refrigerant recovery system.
- b. The recommended method to evacuate and dehydrate the system is to connect three evacuation hoses (see [Figure 7.4](#)) to the vacuum pump and refrigeration unit. Be sure the service hoses are suited for evacuation purposes.
- c. Test the evacuation setup for leaks by backseating the unit service valves and drawing a deep vacuum with the vacuum pump and gauge valves open. Shut off the pump and check to see if the vacuum holds. Repair leaks if necessary.
- d. Midseat the refrigerant system service valves.
- e. Open the vacuum pump and electronic vacuum gauge valves, if they are not already open. Start the vacuum pump. Evacuate unit until the electronic vacuum gauge indicates 2000 microns. Close the electronic vacuum gauge and vacuum pump valves. Shut off the vacuum pump. Wait a few minutes to be sure the vacuum holds.

- f. Break the vacuum with clean dry refrigerant 134a gas. Raise system pressure to approximately 0.2kg/cm² (2psig), monitoring it with the compound gauge.
- g. Remove refrigerant using a refrigerant recovery system.
- h. Repeat steps e. and f. one time.
- i. Remove the copper tubing and change the filter-drier. Evacuate unit to 500 microns. Close the electronic vacuum gauge and vacuum pump valves. Shut off the vacuum pump. Wait five minutes to see if vacuum holds. This procedure checks for residual moisture and/or leaks.
- j. With a vacuum still in the unit, the refrigerant charge may be drawn into the system from a refrigerant container on weight scales. Continue to [Section 7.7](#).

7.6.4 Procedure - Partial System

- a. If the refrigerant charge has been removed from the compressor for service, evacuate only the compressor by connecting the evacuation set-up at the compressor service valves. Follow evacuation procedures of the preceding paragraph except leave compressor service valves frontseated until evacuation is completed.
- b. If refrigerant charge has been removed from the low side only, evacuate the low side by connecting the evacuation set-up at the compressor service valves and liquid service valve except leave the service valves frontseated until evacuation is completed.
- c. Once evacuation has been completed and the pump has been isolated, fully backseat the service valves to isolate the service connections and then continue with checking and, if required, adding refrigerant in accordance with normal procedures.

7.7 REFRIGERANT CHARGE



EXPLOSION HAZARD: Failure to follow this WARNING can result in death, serious personal injury and / or property damage.

Never use air or gas mixtures containing oxygen (O₂) for leak testing or operating the product.

Charge Only With R-134a: Refrigerant must conform to AHRI Standard 700 specification.

7.7.1 Checking the Refrigerant Charge

NOTE

To avoid damage to the earth's ozone layer, use a refrigerant recovery system whenever removing refrigerant. When working with refrigerants you must comply with all local government environmental laws. In the U.S., refer to EPA section 608.

- a. Connect the gauge manifold to the compressor discharge and suction service valves.
- b. Bring the container temperature to approximately 1.7°C (35°F) or -17.8°C (0°F). Set the controller set point to -25°C (-13°F) to ensure that the suction modulation valve is at maximum allowed open position.
- c. Partially block the condenser coil inlet air. If covering the lower portion of the coil is not sufficient, remove the left hand infill panel and cover the left side of the coil. Increase the area blocked until the compressor discharge pressure is raised to approximately 12.8 bar (185 psig).
- d. On the receiver, the level should be between the glasses. If the refrigerant level is not correct, continue with the following paragraphs to add or remove refrigerant as required.

7.7.2 Adding Refrigerant to System (Full Charge)

- a. Evacuate unit and leave in deep vacuum (refer to [Section 7.6](#)).
- b. Place cylinder of R-134a on scale and connect charging line from cylinder to liquid line valve. Purge charging line at liquid line valve and then note weight of cylinder and refrigerant.
- c. Open liquid valve on cylinder. Open liquid line valve half-way and allow the liquid refrigerant to flow into the unit until the correct weight of refrigerant (refer to [Section 3.2](#)) has been added as indicated by scales.

NOTE

It may be necessary to finish charging unit through suction service valve in gas form, due to pressure rise in high side of the system (refer to [Section 7.7.3](#)).

- d. Backseat manual liquid line valve (to close off gauge port). Close liquid valve on cylinder.
- e. Start unit in cooling mode. Run approximately 10 minutes and check the refrigerant charge.

7.7.3 Adding Refrigerant to System (Partial Charge)

- a. Examine the unit refrigerant system for any evidence of leaks. Repair as necessary (refer to [Section 7.5](#)).

- b. Maintain the conditions outlined in [Section 7.7.1](#).
- c. Fully backseat the suction service valve and remove the service port cap.
- d. Connect charging line between suction service valve port and cylinder of refrigerant R-134a. Open VAPOR valve.
- e. Partially frontseat (turn clockwise) the suction service valve and slowly add charge until the refrigerant appears at the proper level.

7.8 COMPRESSOR



Make sure power to the unit is OFF and power plug disconnected before replacing the compressor.

NOTES

1. The compressor should not operate in a vacuum greater than 500mm/hg (20 inches/hg).
2. The service replacement compressor is sold without shutoff valves (but with valve pads), and without terminal box and cover. Customer should retain the original terminal box, cover, and high pressure switch for use on replacement compressor.
3. Check oil level in service replacement compressor (refer to [Section 7.8.6](#)).
4. A compressor terminal wiring kit must be ordered as a separate item when ordering replacement compressor. Appropriate installation instructions are included with kit.
5. Refer to [Table 7-4](#) and [Table 7-5](#) for applicable compressor wear limits and torque values.
6. Refer to [Figure 7.33](#) for charts on compressor pressure, temperature and motor current curves.

7.8.1 Removal and Replacement of Compressor

- a. Remove the protective guard from lower section of the unit.
- b. Pump down low side (refer to [Section 7.4](#)) or frontseat compressor service valves and remove refrigerant from compressor using a refrigerant recovery system.
- c. Locate the compressor junction box. Tag and disconnect wiring from compressor terminals and remove compressor junction box.
- d. Loosen service valve mounting bolts, break seal, and then remove bolts.
- e. Remove compressor plate mounting bolts.
- f. Remove compressor and mounting plate. Refer to [Section 3.2](#) for weight of compressor.

Figure 7.5 Compressor

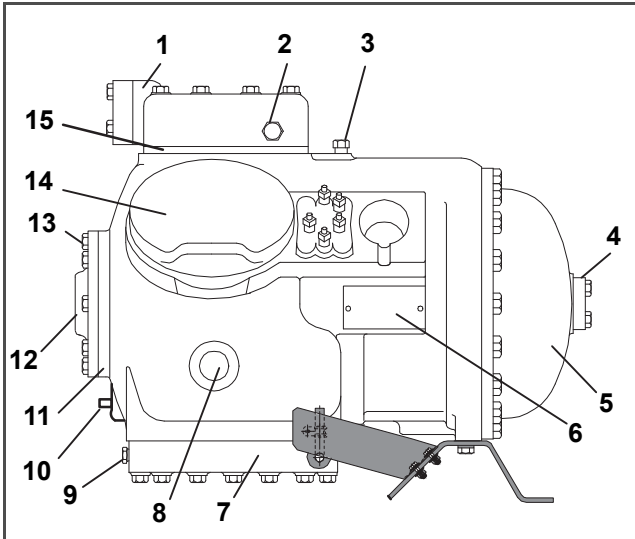

1. Discharge Valve Flange
2. High Side Pressure Connection
3. Low Side Pressure Connection
4. Suction Valve Flange
5. Motor End Cover
6. Serial/Model No. Plate
7. Bottom Plate
8. Sight Glass
9. Oil Drain Plug
10. Oil Charging Valve
11. Bearing Head
12. Oil Pump
13. Oil Fill Plug
14. Cylinder Head
15. Valve Plate

- g. Remove high pressure switch (HPS) from compressor and check operation of switch (refer to [Section 7.9.1](#)).
- h. Remove compressor mounting bolts from mounting plate and install mounting plate on replacement compressor.
- i. Install replacement compressor terminal wiring kit, following instructions included with kit.
- j. Install high pressure switch on compressor.
- k. Install compressor and mounting plate in unit.
- l. Connect junction box(es) to compressor and connect all wiring per wiring diagram. Install junction box cover(s).
- m. Install new gaskets on service valves.
- n. Install mounting bolts in service valves and torque to 2.77 to 4.15mkg (20-30ft/lb).
- o. Attach two hoses (with hand valves near vacuum pump) to the suction and discharge service valves. Dehydrate and evacuate compressor to 500 microns (75.9 cm Hg vacuum = 29.90 inches Hg vacuum). Turn off valves on both hoses to pump.
- p. Fully backseat (open) both suction and discharge service valves.

- q. Remove vacuum pump lines.
- r. Start unit and check refrigerant charge (refer to [Section 7.7](#)).
- s. Check moisture-liquid indicator for wetness. Change filter-drier if necessary (refer to [Section 7.12](#)).
- t. Check compressor oil level per [Section 7.8.6](#). Add oil if necessary.

7.8.2 Compressor Disassembly

! WARNING

Before disassembly of any external compressor component make sure to relieve possible internal pressure by loosening the bolts and tapping the component with a soft hammer to break the seal.

! WARNING

Removing the compressor motor press-fit stator in the field is not recommended. The rotor and stator are a matched pair and should not be separated.

When disassembling compressor, matchmark parts so they may be replaced in their same relative positions (see [Figure 7.5](#)). Refer to [Table 7-4](#) and [Table 7-5](#) for compressor wear limits and bolt torque values.

- a. Place the compressor in a position where it will be convenient to drain the oil. Remove the oil fill plug (see [Figure 7.5](#)) to vent the crankcase. Loosen the drain plug in bottom plate and allow the oil to drain out slowly. Remove the plug slowly to relieve any crankcase pressure. Some units have a plug in the bottom center of the crankcase, which may be removed for draining the motor end more quickly.

Figure 7.6 Exploded View of Valve Plate

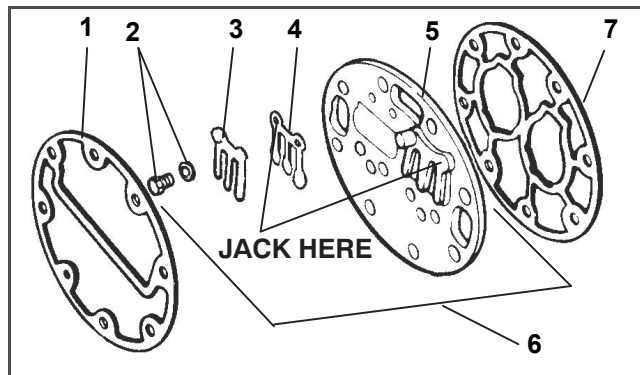

1. Cylinder Head Gasket
2. Discharge Valve Screw & Lockwasher
3. Discharge Valve Stop
4. Discharge Valve
5. Valve Plate
6. Valve Plate Assembly
7. Valve Plate Gasket

Figure 7.7 Bottom Plate Removed

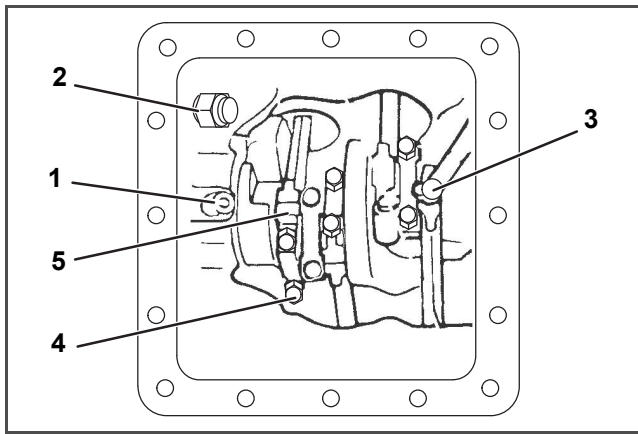

1. Oil Pressure Relief Valve
2. Oil Return Check Valve
3. Oil Suction Tube
4. Cap Screw
5. Connecting Rod and Cap Assembly

- b. Loosen cylinder head cap screws. If the cylinder head is stuck, tap the center of the cylinder head with a wooden or lead mallet. Do not strike the side of the cylinder head. Be careful not to drop the head or damage the gasket sealing surface. Remove cylinder head bolts and gasket (see [Figure 7.6](#)).
- c. Remove valve stops and valves. After they have been removed, free the valve plate from the cylinder deck by using the outside discharge valve hold-down cap screw as a jack screw through the tapped hole of the valve plate. Remove the valve plate gasket.
- d. Turn the compressor on its side and remove the bottom plate oil suction screen and screen hold down plate. Inspect the screen for holes or an accumulation of dirt. The screen can be cleaned with a suitable solvent.
- e. Match mark each connecting rod cap (see [Figure 7.7](#)) and connecting rod for correct reassembly. Remove the bolts and connecting rod caps. Push the piston rods up as far as they will go without having the piston rings extend above the cylinders.

CAUTION

The copper tube that connects to the oil suction strainer extends out the bottom with the bottom plate removed. Take precautions to avoid bending or breaking it while changing crankcase positions.

- f. If necessary, remove the oil return check valve (see [Figure 7.7](#)). Inspect it for proper operation (flow in one direction only). Replace the assembly with a new unit if check valve operation is impaired.
- g. To remove the oil pump (see [Figure 7.8](#)) remove eight cap screws, oil pump bearing head assembly, gasket, and thrust washer.

Figure 7.8 Oil Pump and Bearing Head

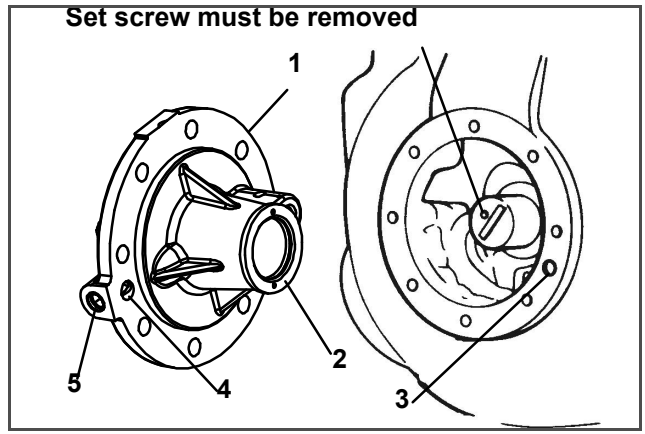

1. Oil Pump & Bearing Head
2. Thrust Washer
3. Oil Pickup Tube
4. Oil Inlet Port
5. Oil Pump Inlet

NOTE

If the oil pump was not operating properly, the entire oil pump & bearing head assembly must be replaced. Individual parts are not available. If the pump requires inspection or cleaning, disassemble and reassemble by referring to [Figure 7.9](#). Clean all parts and coat all moving parts with compressor oil before proceeding with reassembly.

Figure 7.9 Low Profile Oil Pump

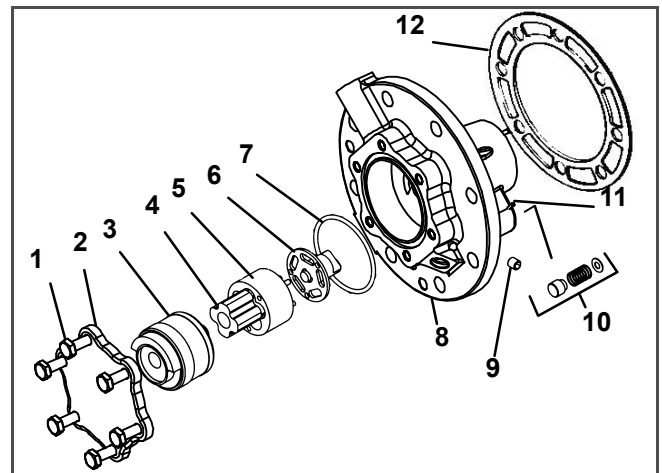

1. Cap screws
2. Cover
3. Reversing Assembly
4. Pinion
5. Gear
6. Drive
7. O-Ring
8. Oil Pump & Bearing
9. Set Screw
10. Relief Valve
11. Pin
12. Gasket

- h. Be very careful not to damage the motor windings when removing the motor end cover (see [Figure 7.10](#)), as the cover fits over the winding coils. Loosen the cap screws, break the seal, and then remove all cap screws except one in the top of the cover. While holding the cover in place, remove the remaining cap screw. Do not allow the cover to drop from its own weight. To prevent striking the winding, remove the cover horizontally and in line with the motor axis.

Figure 7.10 Motor End Cover

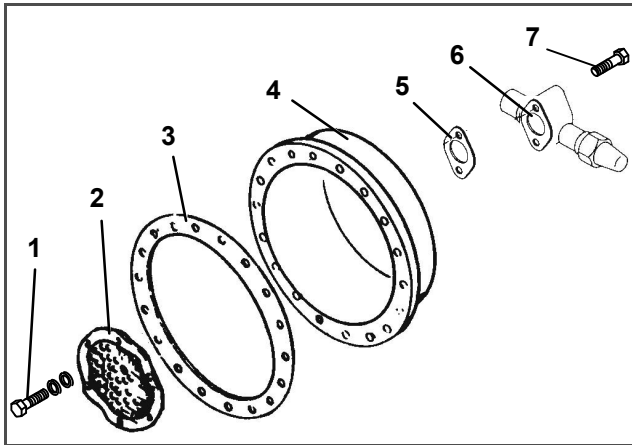

1. Strainer Screws and Washers
2. Suction Strainer
3. Motor End Cover Gasket
4. Motor End Cover
5. Valve Gasket
6. Suction Service Valve
7. Valve Cap Screw

- i. Remove the refrigerant suction strainer. If it is removed with ease, it may be cleaned with solvent and replaced. If the strainer is broken, corroded or clogged with dirt that is not easily removed, replace the strainer. Install new gaskets upon reassembly.
- j. Block the compressor crankshaft so that it cannot turn. Use a screwdriver to bend back the tabs on the lockwasher, and remove the equalizer tube and lock screw assembly (see [Figure 7.11](#)). The slingers at the end of the tube draw vapor from the crankcase. Remove the rotor using a jack bolt. Insert a brass plug into the rotor hole to prevent damage to the end of the crankshaft.
- k. If the piston rings extend beyond the cylinder tops, the pistons can be pulled through the bottom plate opening after the piston rings are compressed. A piston ring compressor will facilitate removal. Each piston pin is locked in place by lock rings, which are snapped into grooves in the piston wall (see [Figure 7.12](#)).
- l. Since the stator cannot be replaced in the field, the terminal plate assembly need not be disturbed unless a leak exists and the plate assembly needs to be replaced. If no terminal plate repair is required, proceed with reassembly.

Figure 7.11 Equalizing Tube and Lock Screw Assembly

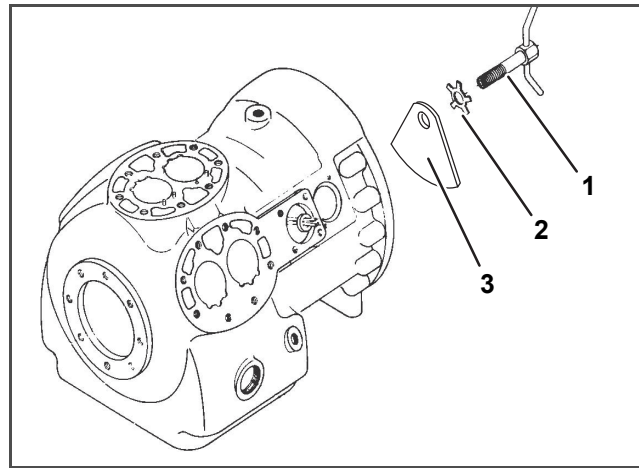

1. Equalizer Tube and Lock Screw Assembly
2. Lockwasher
3. Counterweight - Motor End

Figure 7.12 Crankshaft Assembly

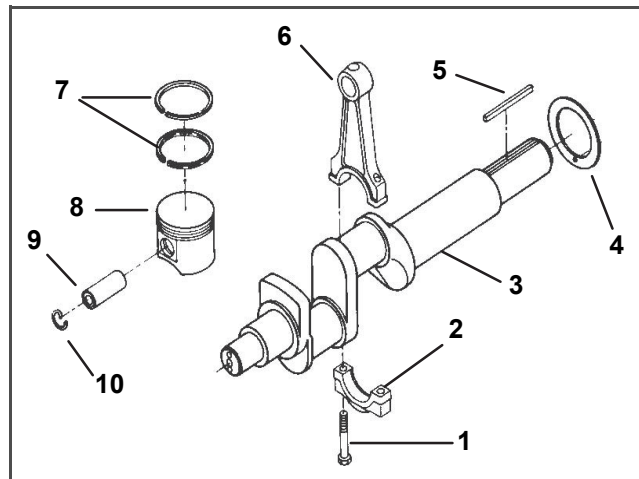

1. Cap Screw
2. Cap
3. Crankshaft
4. Thrust Washer
5. Rotor Drive Key
6. Connecting Rod
7. Compression Ring
8. Piston
9. Pin
10. Retainer

7.8.3 Compressor Reassembly

Clean all compressor parts, using a suitable solvent with proper precautions. Coat all moving parts with the proper compressor oil before assembly. Refer to [Table 7-5](#) for applicable compressor torque values.

7.8.4 Preparation

a. Suction and Discharge Valves

If the valve seats look damaged or worn, replace valve plate assembly. Always use new valves because it is difficult to reinstall used valves so that they will seat as before removal. Any valve wear will cause leakage.

Figure 7.13 Suction Valve and Positioning Rings

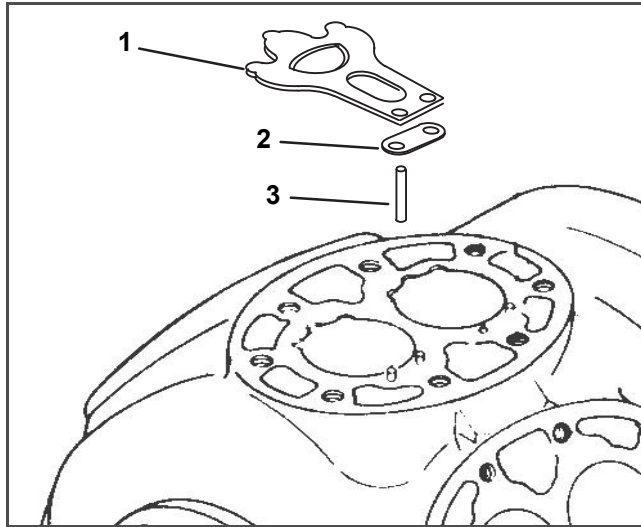

1. Suction Valve
2. Suction Valve Positioning Spring
3. Valve Plate Dowel Pin

Suction valves are positioned by dowel pins (see [Figure 7.13](#)). Do not omit the suction valve positioning springs. Place the springs so that the ends bear against the cylinder deck (middle bowed away from cylinder deck). Use new gaskets when reinstalling valve plates and cylinder heads.

b. Compression Rings

The compression ring is chamfered on the inside circumference. This ring is installed with the chamfer toward the top. Stagger the ring end gaps so they are not aligned.

Figure 7.14 Piston Ring

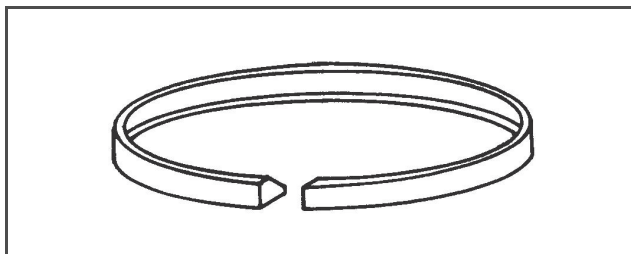

The gap between the ends of the piston rings can be checked with a feeler gauge by inserting the ring into the piston bore approximately one inch below the top of the bore. Square the ring in the bore by pushing it slightly with a piston. The maximum and minimum allowable ring gaps are 0.33 and 0.127mm (0.013 and 0.005 inch) respectively.

7.8.5 Installing the Components

- a. Push pistons from the inside of the crankcase through the cylinders, be careful not to break rings. Place rods so that the chamfered side is against radius of crankpins. Install the crankshaft and thrust washer through the pump end of the compressor. Ensure thrust washer is fitted on locating pin. Do not damage main bearings. Bring rods in position against crank bearings.
- b. Install the pump end thrust washer on the two dowel pins located on the bearing head (see [Figure 7.8](#)).

CAUTION

Ensure that the thrust washer does not fall off dowel pins while installing oil pump.

CAUTION

The set screw on the crankshaft must be removed for this type of oil pump (see [Figure 7.8](#)).

- c. Install bearing head assembly with a new gasket on the compressor crankshaft. Carefully push oil pump on by hand, ensuring the thrust washer remains on the dowel pins. The tang on the end of the drive engages the slot in the crankshaft, and the oil inlet port on the pump is aligned with the oil pickup tube in the crankcase. The pump should be mounted flush with the crankcase, and oriented with the oil pick up tube and oil inlet port, and aligned as shown in [Figure 7.8](#).
- d. Align gasket and install eight cap screws in mounting flange. Refer to [Table 7-5](#) for torque values.
- e. Install matching connecting rod caps. Be sure rod is not bound and crankshaft will turn correctly as each set of rod bolts is torqued.
- f. Be sure key fits properly when installing rotor on shaft. Screw on equalizer tube and lock screw assembly with lock washer and bend over tabs of lock washer. Assemble suction strainer to motor and cover, and bolt cover to crankcase. Assemble valve plates and gaskets. Assemble cylinder heads & gaskets. Turn shaft by hand to see that it moves freely.
- g. Install the oil suction screen, the oil suction screen hold down plate, and the bottom plate.

7.8.6 Compressor Oil Level

CAUTION

Use only Carrier Transicold approved Polyol Ester Oil (POE) – Castrol-Icematic SW20 compressor oil with R-134a. Buy in quantities of one quart or smaller. When using this hygroscopic oil, immediately reseal. Do not leave container of oil open or contamination will occur.

Checking the Oil Level in the Compressor

1. Turn unit on and operate in cooling mode for at least 20 minutes.
2. Check the front oil sight glass on the compressor to ensure that no foaming of the oil is present after 20 minutes of operation. If the oil is foaming excessively after 20 minutes of operation, check the refrigerant system for flood-back of liquid refrigerant. Correct this situation before performing step 3.
3. Turn unit off to check the oil level. The correct oil level range should be between the bottom to one-eighth level of the sight glass. If the level is above one-eighth, oil must be removed from the compressor. To remove oil from the compressor, follow step d in this section. If the level is below the bottom of the sight glass, add oil to the compressor following step b below.

b. Adding Oil with Compressor in System

1. The recommended method is to add oil using an oil pump at the oil fill valve (see item 10, [Figure 7.5](#)).
2. In an emergency where an oil pump is not available, oil may be drawn into the compressor through the suction service valve.

Connect the suction connection of the gauge manifold to compressor suction service valve port and immerse the common connection of the gauge manifold in a container of refrigeration oil. Extreme care must be taken to ensure the manifold common connection remains immersed in oil at all times. Otherwise air and moisture will be drawn into compressor.

Crack the suction service valve and gauge valve to vent a small amount of refrigerant through the common connection and the oil to purge the lines of air. Close the gauge manifold valve.

With the unit running, frontseat the suction service valve and induce a vacuum in the compressor crankcase. SLOWLY crack the suction gauge manifold valve and oil will flow through the suction service valve into the compressor. Add oil as necessary.

c. Adding Oil to Service Replacement Compressor

Service replacement compressors are shipped without oil. If oil is present in crankcase, test the oil to ensure it is the correct oil and that moisture level is acceptable.

When adding oil to a service replacement compressor add three liters (6.3 pints) using an oil pump at the oil fill valve (see item 10, [Figure 7.5](#)). This quantity is recommended to allow for return of any oil that may be in the refrigerant system. Install compressor and check oil level after it is placed in operation (refer to [Section 7.8.6](#)).

d. Removing Oil from the Compressor

1. If the oil level is above one-eighth sight glass, excess oil must be removed from the compressor.
2. Close (frontseat) suction service valve and pump unit down to 0 to .1 bar (0 to 2 psig).
3. Turn the unit off.
4. Frontseat discharge service valve and remove the remaining refrigerant.
5. Loosen the oil drain plug on the bottom plate of the compressor and drain the proper amount of oil from the compressor to obtain the correct level.
6. Tighten the oil drain plug.
7. Backseat the suction and discharge service valves.
8. Repeat step a to ensure proper oil level.

7.9 HIGH PRESSURE SWITCH

7.9.1 Checking High Pressure Switch



Do not use a nitrogen cylinder without a pressure regulator.

NOTE

The high pressure switch is non-adjustable.

- a. Remove switch as outlined in [Section 7.9.2](#).
- b. Connect ohmmeter or continuity light across switch terminals. Ohm meter will indicate no resistance or continuity light will be illuminated if the switch closed after relieving compressor pressure.
- c. Connect hose to a cylinder of dry nitrogen, see [Figure 7.15](#).

Figure 7.15 High Pressure Switch Testing

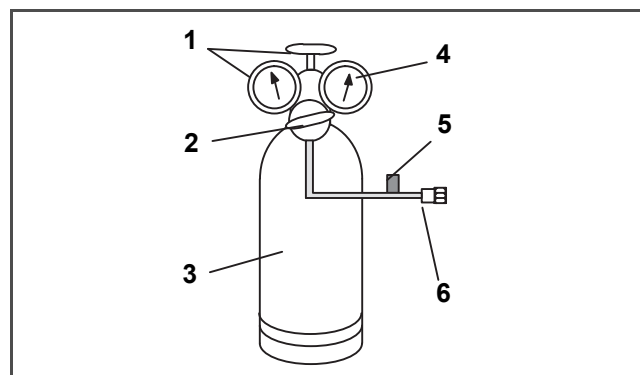

1. Cylinder Valve and Gauge
2. Pressure Regulator
3. Nitrogen Cylinder
4. Pressure Gauge (0 to 36 kg/cm² = 0 to 400 psig)
5. Bleed-Off Valve
6. 1/4 Inch Connection

- d. Set nitrogen pressure regulator at 26.4kg/cm² (375psig) with bleed-off valve closed.
- e. Close valve on cylinder and open bleed-off valve.
- f. Open cylinder valve. Slowly close bleed-off valve to increase pressure on switch. The switch should open at a static pressure up to 25kg/cm² (350 psig). If a light is used, light will go out. If an ohmmeter is used, the meter will indicate open circuit.
- g. Slowly open bleed-off valve to decrease the pressure. The switch should close at 18kg/cm² (250 psig).

7.9.2 Replacing the High Pressure Switch

- a. Turn unit start-stop switch OFF. Frontseat both suction and discharge service valves to isolate compressor. Remove the refrigerant from the compressor.
- b. Disconnect wiring from defective switch. The high pressure switch is located on the center head and is removed by turning counterclockwise (see [Figure 3.3](#)).
- c. Install a new high pressure switch after verifying switch settings (refer to [Section 7.9.1](#)).
- d. Evacuate and dehydrate the compressor per [Section 7.6](#).

7.10 CONDENSER COIL

The condenser coil consists of a series of parallel copper tubes expanded into copper fins and formed into a "C" shape with the fourth side of the square formed by the side support bracket.

7.10.1 Condenser Coil Cleaning

To ensure optimal efficiency of the unit the condenser coil must be clean. The condenser coil should be cleaned at least once a year, but more frequent cleaning may be required depending on operating conditions. The coil is cleaned with fresh water sprayed in the reverse direction of the air flow to remove any debris from the coil. A high pressure washer is not required, mains water pressure is sufficient. To clean the condenser coil perform the following procedure:



Do not remove the condenser fan grille before turning power OFF and disconnecting the power plug.

- a. Make sure the unit is powered off and the plug is disconnected.
- b. Remove the condenser fan grille.
- c. Starting from the top of the coil, use a water hose with a nozzle to wash the coil from the inside out.

- d. Systematically wash across the inside top face of the coil until the water runs clean.
- e. Wash down the center section, and then through the bottom of the coil, continue washing until the water runs clear.
- f. After the coil is clean, rinse the condenser fan to remove any dirt build up from the blades.
- g. Replace the condenser fan grille ensuring that it is centered around the fan.

7.10.2 Condenser Coil Removal

- a. Using a refrigerant reclaim system remove the refrigerant charge.



Do not remove the condenser fan grille before turning power OFF and disconnecting the power plug.

- b. Remove the condenser fan grille, retain all bolts and washers for reuse.
- c. Remove the condenser fan.
- d. Remove the infill panels to the left and right of the condenser fan shroud.
- e. Remove the condenser fan shroud.
- f. Unplug the condenser fan motor.
- g. Remove and retain sufficient putty from around the motor wire harness to allow the harness to be slid back through the side support bracket.
- h. Cut the top and bottom drain lines midway between the side support bracket and the first cable tie, approx 150mm (6") from the side support bracket.
- i. Remove and retain sufficient putty from around the drain lines to allow the tubes to be slid back through the side support bracket.
- j. Remove filter drier.
- k. Unbrazed the inlet connection to coil.
- l. Remove the cushion clamps securing the liquid line to the top and bottom receiver brackets, retain all clamps and securing hardware.
- m. Place a support under the condenser coil before releasing the coil from the frame.
- n. Remove the lower mounting bracket bolts from the inside of the coil.
- o. Remove the top mounting bracket bolts and grille extension mount from inside the coil.
- p. Remove the side support bracket mounting bolts.
- q. Slide the condenser assembly with receiver out of the unit.

7.10.3 Condenser Coil Preparation

Before installing the new condenser coil, the receiver assembly and mounting hardware must be removed from the old coil assembly:

- a. From the old coil, unbolt the receiver assembly from side support bracket.
- b. Unbrazed the receiver assembly from the coil outlet line and remove from the coil assembly.
- c. Unbolt the side support bracket from the top and bottom coil supports and remove from old coil.
- d. Refit the side support bracket to the new coil ensuring that the top and bottom are flush mounted with the coil support.

7.10.4 Condenser Coil Installation

Once the side support bracket has been secured to the new condenser coil, the entire assembly is ready to be installed into the unit:

- a. Slide the new condenser coil into place ensuring the coil inlet connection is mated to the pipework and that the coil is fully supported.
- b. Secure the condenser coil into the unit using the retained hardware; refit the mylar and fender washers:
 1. Refit the side support bracket bolts.
 2. Refit the top support bracket bolts as well as the top grille extension support.
 3. Refit the bottom support bracket bolts.
- c. Braze the condenser coil inlet connection.
- d. Insert the receiver pipe work onto the coil outlet and loosely secure the receiver assembly to the side support bracket with the retained hardware.
- e. Braze the outlet connection to the receiver assembly.
- f. Install a new filter drier.
- g. Replace the liquid line cushion clamps.
- h. Secure the receiver assembly to the side support bracket.
- i. Pressure / leak test the coil and filter drier connections, refer to [Section 7.5](#).
- j. Evacuate the entire unit, refer to [Section 7.6](#).
- k. Slide the top and bottom drain lines back into place through the side support bracket.
- l. Using the two supplied straight connectors and contact adhesive reconnect the drain lines.

- m. Slide the condenser fan motor wiring harness back through the side support bracket and refit to condenser motor.
- n. Replace all wire ties that were removed to properly secure the drain line and wiring.
- o. Reseal the wire harness and drain line penetrations with the putty.
- p. Slide the condenser fan onto the motor shaft reversed but do not secure.
- q. Refit the condenser fan shroud to the unit. Use the condenser fan as a guide to ensure the shroud is properly centered around the fan.
- r. Remove the condenser fan, and place it on the shaft facing the correct direction. Adjust the fan to the correct position, 37mm (1.5") from the fan shroud, see [Figure 7.16](#).

Figure 7.16 Condenser Fan Position

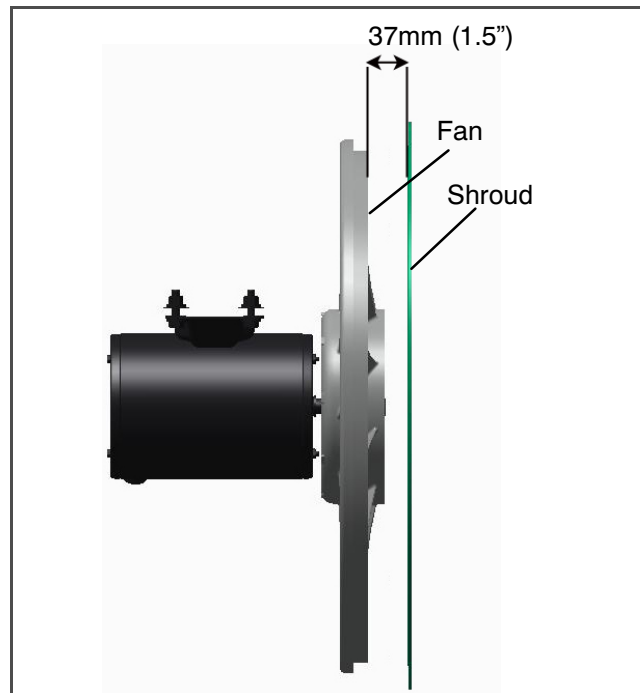

- s. Use Loctite "H" on the fan set screws, and tighten.
- t. Refit left and right infill panels.
- u. Refit the condenser fan grille, ensuring the grille is properly centered around the condenser fan.
- v. Evacuate the entire unit, refer to [Section 7.6](#).
- w. Recharge the unit with the charge shown on the unit serial plate, refer to [Section 7.7](#). It is important for proper unit operation that the charge is weighed into the unit.

7.11 CONDENSER FAN AND FAN MOTOR

The condenser fan rotates counter-clockwise (viewed from front of unit). The fan pulls air through the condenser coil, and discharges the air horizontally through the front of the unit.

7.11.1 Condenser Fan Motor Remove/Replace



Do not remove the condenser fan grille before turning power OFF and disconnecting the power plug.

- a. Remove the condenser fan grille, retain all bolts and washers for reuse.
- b. Remove the condenser fan by loosening the two set screws.
- c. Disconnect the condenser fan motor wiring.



Take necessary steps (place plywood over coil or use sling on motor) to prevent motor from falling into condenser coil.

- d. Note the number of shims on each side of the motor as the same configuration will be required to refit the new motor.
- e. Remove the fan motor mounting hardware and remove motor.
- f. Loosely mount the new motor using new lock nuts.
- g. Replace the shims in the same configuration as they were removed.
- h. Tighten the fan motor mounting bolts to properly secure the motor.
- i. To make sure that the motor is aligned properly, slide the condenser fan onto the motor shaft reversed but do not secure.
- j. Rotate the fan to make sure the fan blades do not contact the shroud:
 1. If the fan motor is misaligned vertically, add or remove shims to align.

2. If the fan motor is not properly centered, loosen the mounting bolts, and adjust the motor position on the bracket, and then secure the motor.

- k. Remove the condenser fan, and connect the fan motor wiring to the fan motor.
- l. Place the condenser fan on the shaft facing the correct direction. Adjust the fan to the correct position, 37mm (1.5") from the fan shroud, see [Figure 7.16](#).
- m. Use Loctite "H" on the fan set screws, and tighten.
- n. Refit the left and right infill panels.
- o. Refit the condenser fan grille, ensuring the grille is properly centered around condenser fan.

7.12 FILTER-DRIER

- a. To check filter drier:

1. Test for a restricted or plugged filter-drier by feeling the liquid line inlet and outlet connections of the drier cartridge. If the outlet feels cooler than the inlet, then the filter-drier should be changed.
2. Check the moisture-liquid indicator, if indicator shows a high level of moisture, the filter-drier should be replaced.

- b. To replace filter drier:

1. Pump down the unit (refer to [Section 7.4](#)) and replace filter-drier.
2. Evacuate the low side in accordance with [Section 7.6](#).
3. After unit is in operation, inspect for moisture in system and check charge.

7.13 EVAPORATOR COIL & HEATER ASSEMBLY

The evaporator section, including the evaporator coil, should be cleaned regularly. The preferred cleaning fluid is fresh water or steam. Another recommended cleaner is Oakite 202 or similar, following manufacturer's instructions.

The two drain pan hoses are routed behind the condenser fan motor and compressor. The drain pan line(s) must be open to ensure adequate drainage.

7.13.1 Evaporator Coil Replacement

- a. Pump unit down. (Refer to [Section 7.4](#)).

WARNING

Always turn OFF the unit circuit breakers (CB-1 & CB-2) and disconnect main power supply before working on moving parts.

- b. With power OFF and power plug removed, remove the screws securing the panel covering the evaporator section (upper panel).
- c. Disconnect the defrost heater wiring.
- d. Remove the mounting hardware from the coil.
- e. Unsolder the two coil connections, one at the distributor and the other at the coil header.
- f. Disconnect the defrost temperature sensor (refer to [Section 7.21](#)) from the coil.
- g. Remove middle coil support.
- h. After defective coil is removed from unit, remove defrost heaters and install on replacement coil.
- i. Install coil assembly by reversing above steps.
- j. Leak check connections. Evacuate and add refrigerant charge.

7.13.2 Evaporator Heater Replacement

The heaters are wired directly back to the contactor and if a heater failure occurs during a trip, the heater set containing that heater may be disconnected at the contactor.

The next Pre-trip (P1) will detect that a heater set has been disconnected and indicate that the failed heater should be replaced. To remove a heater, do the following:

WARNING

Always turn OFF the unit circuit breakers (CB-1 & CB-2) and disconnect main power supply before working on moving parts.

- a. Before servicing unit, make sure the circuit breakers (CB-1 and CB-2) and start-stop switch (ST) are in the OFF position, and the power plug is disconnected.
- b. Remove the upper back panel.
- c. Determine which heater(s) need replacing by checking resistance of each heater set. Refer to [Section 3.3](#) for heater resistance values. Once the set containing the failed heater is determined, cut the splice connection and retest to determine the actual failed heater(s).
- d. Remove hold-down clamp securing heater(s) to coil.
- e. Lift the bent end of the heater (with the opposite end down and away from coil). Move heater to the side enough to clear the heater end support and remove.
- f. To replace a heater, do steps a through e in reverse.

Figure 7.17 Heater Arrangement

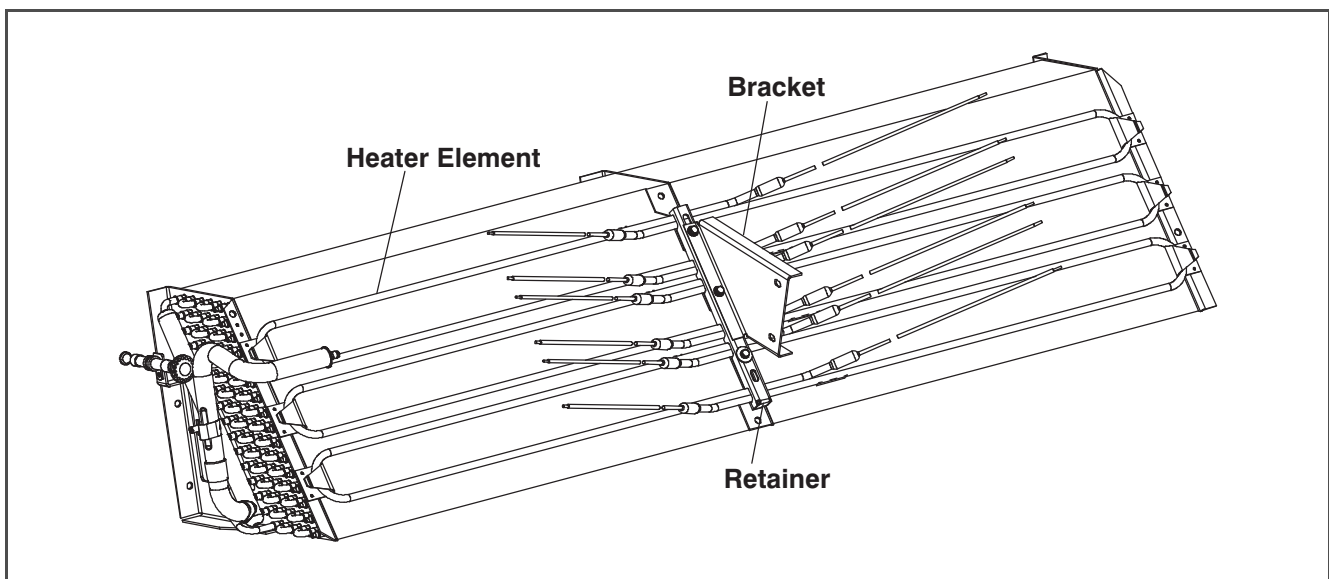

7.14 EVAPORATOR FAN AND MOTOR ASSEMBLY

The evaporator fans circulate air throughout the container by pulling air in the top of the unit. The air is forced through the evaporator coil where it is either heated or cooled and then discharged out the bottom of the refrigeration unit into the container. The fan motor bearings are factory lubricated and do not require additional grease.

7.14.1 Replacing the Evaporator Fan Assembly

WARNING

Always turn OFF the unit circuit breakers (CB-1 & CB-2) and disconnect main power supply before working on moving parts.

- Remove access panel by removing mounting bolts and TIR locking device. Reach inside of unit and remove the Ty-Rap securing the wire harness loop. Disconnect the connector by twisting to unlock and pulling to separate.
- Loosen four 1/4-20 clamp bolts that are located on the underside of the fan deck at the sides of the fan assembly. Slide the loosened clamps back from the fan assembly.
- Slide the fan assembly out from the unit and place on a sturdy work surface.

7.14.2 Disassemble the Evaporator Fan Assembly

- Attach a spanner wrench to the two 1/4-20 holes located in the fan hub. Loosen the 5/8-18 shaft nut by holding the spanner wrench stationary and turning the 5/8-18 nut counter-clockwise (see [Figure 7.18](#)).
- Remove the spanner wrench. Use a universal wheel puller and remove the fan from the shaft. Remove the washers and key.
- Remove the four 1/4-20 x 3/4 long bolts that are located under the fan that support the motor and stator housing. Remove the motor and plastic spacer.

7.14.3 Assemble the Evaporator Fan Assembly

- Assemble the motor and plastic spacer onto the stator.

NOTE

When removing the black nylon evaporator fan blade, care must be taken to assure that the blade is not damaged. In the past, it was a common practice to insert a screwdriver between the fan blades to keep it from turning. This practice can no longer be used, as the blade is made up of a material that will be damaged. It is recommended that an impact wrench be used when removing the blade. Do not use the impact wrench when reinstalling, as galling of the stainless steel shaft can occur.

- Apply Loctite to the 1/4-20 x 3/4 long bolts and torque to 0.81 mkg (70 inch-pounds).

- Place one 5/8 flat washer on the shoulder of the fan motor shaft. Insert the key in the keyway and lubricate the fan motor shaft and threads with a graphite-oil solution (such as Never-seez).
- Install the fan onto the motor shaft. Place one 5/8 flat washer with a 5/8-18 locknut onto the motor shaft and torque to 40 foot-pounds.

Figure 7.18 Evaporator Fan Assembly

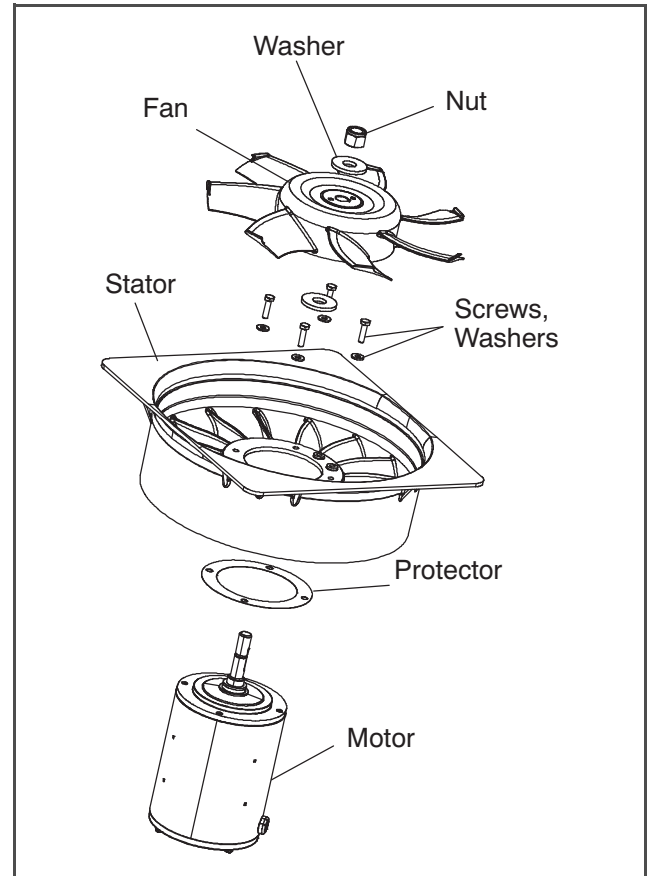

- Install the evaporator fan assembly in reverse order of removal. Torque the four 1/4-20 clamp bolts to 0.81 mkg (70 inch-pounds). Connect the wiring connector.
- Replace access the panel making sure that the panel does not leak. Make sure that the TIR locking device is lockwired.

7.15 EVAPORATOR SECTION CLEANING

Containers and Container units that are exposed to certain fumigants may develop visible surface corrosion. This corrosion will show up as a white powder found on the inside of the container and on the reefer unit evaporator stator and fan deck.

Analyses by Carrier Transicold environmental specialists have identified the white powder as consisting predominantly of aluminum oxide. Aluminum oxide is a coarse crystalline deposit most likely the result of surface corrosion on the aluminum parts within the container. If left untreated over time, it may build up in thickness and eventually flake as a light-weight white powder.

The surface corrosion of aluminum is brought about by exposure to chemicals such as sulfur dioxide and possibly other fumigants that are commonly used for fumigation and protection of some perishable cargo such as grapes, for example. Fumigation is the process by which a chemical is released into an enclosed area to eliminate infestations of insects, termites, rodents, weeds and soil-borne disease.

Typically any aluminum oxide that becomes detached from evaporator fan stators will be blown into the wet evaporator coil where it will be caught and then flushed out of the unit during routine defrost cycles.

However, it is still highly recommended that after carrying cargo subject to fumigation procedures, that the inside of the unit be thoroughly cleansed prior to reuse.

Carrier Transicold has identified a fully biodegradable and environmentally safe alkaline cleaning agent (Tri-Pow'r® HD) for the unit. This will assist in helping to remove the corrosive fumigation chemicals and dislodging of the corrosive elements.

This cleaner is available from the Carrier Transicold Performance Parts Group (PPG) and can be ordered through any of the PPG locations; Part Number NU4371-88.

As a general safety precaution, before using this product, refer to and retain the Material Safety Data (MSDS) sheet. This document can be found at:

www.nucalgon.com/products/coil_cleaners_tripower.htm

Prior to Cleaning:

- Always wear goggles, gloves and work boots.
- Avoid contact with skin and clothing, and avoid breathing mists.
- When mixing, add water to the sprayer first, then the cleaner.
- ALWAYS provide for proper ventilation when cleaning indoor evaporator coils (rear doors must be open).
- Be aware of surroundings – food, plants, etc., and the potential for human exposure.
- Always read directions and follow recommended dilution ratios. More is not always better. Using non-diluted cleaner is not recommended.

Cleaning Procedure:

- a. Remove the upper evaporator access panel inside of the unit.
- b. Spray the surface with water before applying the cleaning solution. This helps the cleaner work better.
- c. Liberally apply the prepared cleaner solution (5 parts water and 1 part cleaner).
- d. Allow the cleaner to soak in for 5 to 7 minutes.
- e. Assess area for rinsing. Follow all local regulations regarding disposal of waste water.
- f. Thoroughly rinse the cleaner and surrounding area, floor, etc. When rinsing where heavy foaming solution is present, it is very important to take the time to thoroughly rinse the equipment and surroundings.

- g. Always rinse the empty coil cleaner bottle, cap tightly and dispose of properly.

7.16 THERMOSTATIC EXPANSION VALVE

The thermostatic expansion valve (TXV) (see [Figure 3.2](#)) is an automatic device that maintains constant superheat of the refrigerant gas leaving the evaporator, regardless of suction pressure.

TXV functions are:

1. Automatic control of the refrigerant flow to match the evaporator load.
2. Prevention of liquid refrigerant entering compressor.

Unless the valve is defective, it seldom requires maintenance other than periodic inspection to ensure that the thermal bulb is tightly secured and properly insulated. See [Figure 7.19](#).

NOTE

TXV Bulb Clamp is soldered to the suction line.

Figure 7.19 Thermostatic Expansion Valve Bulb

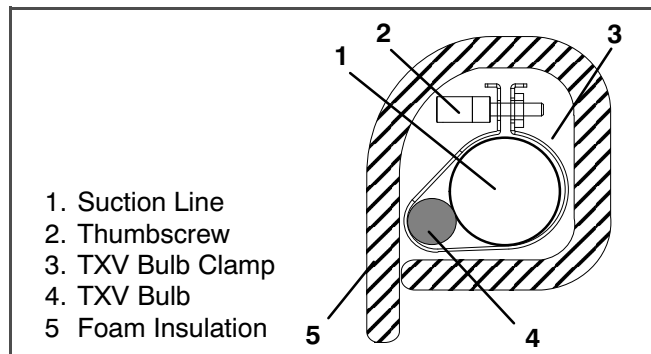

7.16.1 Checking Superheat

NOTE

Proper superheat measurement should be completed at -18°C (0°F) container box temperature where possible.

- a. Open the upper right (EFM#1) access panel (see [Figure 3.1](#)) to expose the expansion valve.
- b. Attach a temperature sensor near the expansion valve bulb and insulate. Make sure the suction line is clean and that firm contact is made with the sensor.
- c. Connect an accurate gauge to the service port directly upstream of the suction modulating valve.
- d. Set the temperature set point to -18°C (0°F) and run unit until conditions stabilize.
- e. The readings may cycle from a high to a low reading. Take readings of temperature and pressure every three to five minutes for a total of 5 or 6 readings.
- f. From the temperature/pressure chart ([Table 7-6](#)), determine the saturation temperature corresponding to the evaporator outlet test pressures at the suction modulation valve.
- g. Subtract the saturation temperatures in step f from the temperatures measured in step e. The difference is the superheat of the suction gas. Determine the average superheat. It should be 4.5 to 6.7°C (8 to 12°F).

7.16.2 TXV Replacement

NOTES

1. The TXV is a hermetic valve, it does not have adjustable superheat (See [Figure 7.20](#)).
2. All connections on the hermetic TXV are bi-metallic, copper on the inside and stainless on the outside.
3. All joints on the hermetic TXV (inlet, outlet and equalizer lines) are brazed.
4. Bi-metallic connections heat up very quickly.

Figure 7.20 Thermostatic Expansion Valve

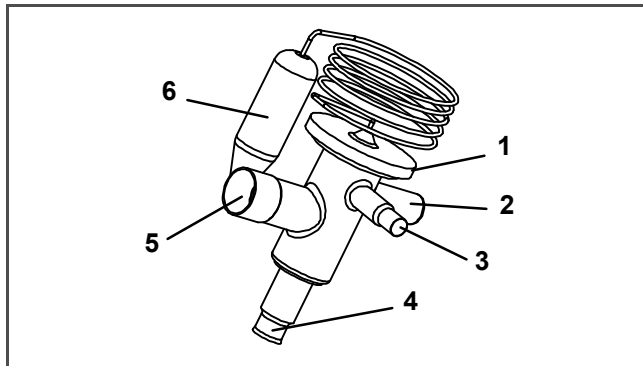

1. Hermetic Thermostatic Expansion Valve
2. Non-adjustable Superheat Stem
3. Equalizer Connection
4. Inlet Connection
5. Outlet Connection
6. Hermetic Expansion Valve Bulb

a. Removing the TXV:

1. Pump down the unit per [Section 7.4](#).
2. If TXV replacement is to be performed from the front of the unit, open the upper right (EFM#1) access panel (see [Figure 3.1](#)) to remove evaporator fan motor.
3. Remove cushion clamp that secures the valve body to the bracket.

4. Unbrazed the equalizer connection (1/4"), the outlet connection (5/8"), and then the inlet connection (3/8"). See [Figure 7.22](#). Be careful to protect the insulation on the heaters and their wires.
5. Open the insulation flap. Flap is secured with Velcro (Item 3, [Figure 7.21](#)).
6. Loosen the thumb screw and slide the bulb, out by pulling it towards the front of the unit.

Figure 7.21 Hermetic Thermostatic Expansion Valve Bulb Location

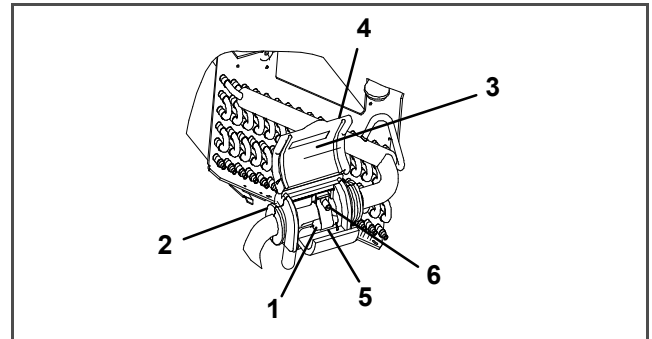

1. Hermetic Expansion Valve Bulb
2. Insulation
3. Insulation Flap
4. Velcro strip
5. Bulb Clamp
6. Thumb Screw

b. Installing the TXV

1. Braze inlet connection to inlet line (see [Figure 7.22](#)).
2. Braze outlet connection to outlet line.
3. Braze the equalizer connection to the equalizer line.
4. Reinstall the cushion clamp.
5. Thread the thermal bulb through the opening above the evaporator coil (see [Figure 3.2](#)), and slide it under the strap and secure the thumb screw. Close the insulation flap. Reinstall bulb access panel.
6. Check superheat (refer to step 7.16.1).

Figure 7.22 Hermetic Thermostatic Expansion Valve Brazing Procedure

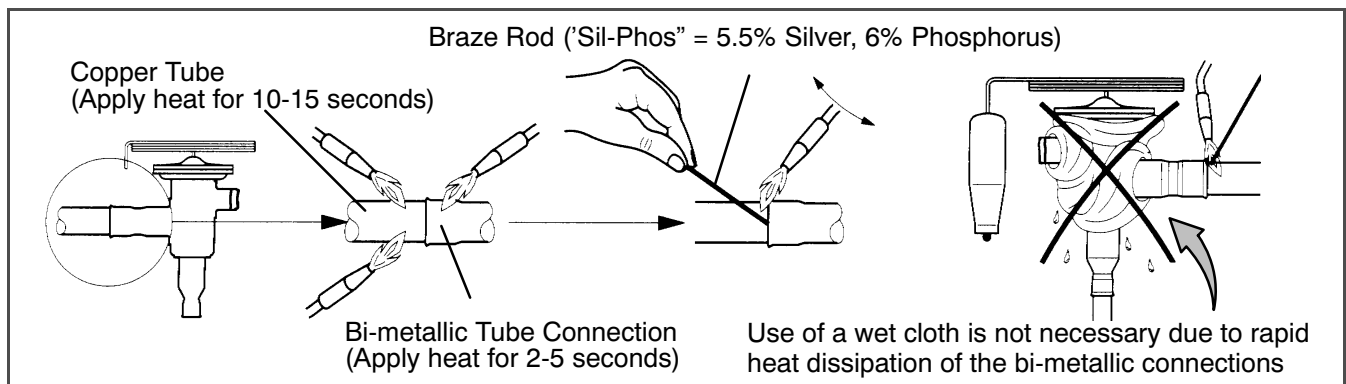

7.17 SUCTION MODULATION VALVE

On start up of the unit, the SMV will reset to a known open position. This is accomplished by assuming the valve was fully open, driving it fully closed, resetting the percentage open to zero, then opening to a known 21% staging position.

Figure 7.23 Suction Modulation Valve (SMV)

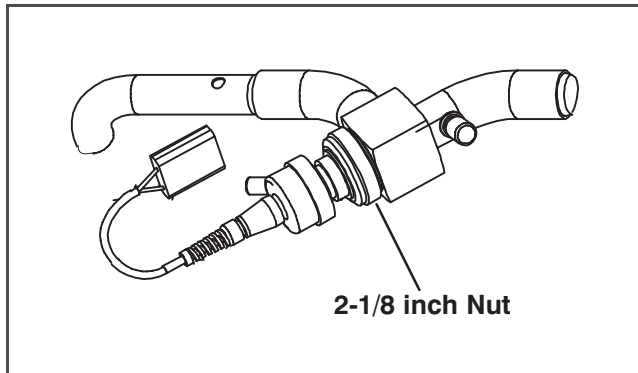

7.17.1 Pre-check Procedure

- a. Check unit for abnormal operation.
- b. Check charge. If refrigerant is low repair as required and again check operation.
- c. If sufficient capacity cannot be maintained or unit is tripping excessively on high pressure switch (HPS) in high ambients, check coils and clean if required.
- d. If capacity or control cannot be maintained, turn unit OFF, then back ON. This will reset the SMV in the event the controller lost communication with the valve, and may correct the problem.

NOTE

Carefully listen to the valve. During reset, the valve will make a ratcheting noise that may be heard or felt as it is attempting to close. If this can be heard or felt, it indicates that the controller and drive module are attempting to close the valve, and may serve as a quick indication that the drive module is in working order.

- e. During the first few minutes of unit operation, compressor reliability enhancement logic (CREL) may be in effect. This places the valve at a 21% staging position and is sufficient to drive the temperature of the supply probe down several degrees during this interval.

- f. After the CREL time-out has been met, the valve will start responding to the control logic and open or close relative to the demand. Scrutinize the unit operation for a few minutes. While in pulldown, the unit will open the SMV to a maximum discharge pressure of 325 psig in high ambient conditions, or as much as the current setting and control logic will allow. The current level should be high. A lower discharge pressure will be seen in lower ambient temperatures. Once the unit has reached set point, the SMV will go into control mode. Both the discharge/suction pressures, and current draw will go significantly lower. Once below set point, the suction pressure should go into a vacuum within several minutes. Should the operation differ as mentioned, the SMV, controller, or wiring, may be faulty.
- g. Check for correct wire location at the stepper motor plug and the environmental connector (EC). Make sure that the wires terminate in accordance with the wire markings (addresses).
- h. Attach a manifold gauge set (refer to [Section 7.2](#)). If the unit is operating in the perishable mode, proceed to step i. If the unit is operating in the frozen mode, proceed to step j.
- i. Perishable operation: If the operation of the unit is in question, place the set point to approximately 6°C (11°F) less than the current box temperature, so the unit goes into pulldown. Run the unit for approximately one minute. Record readings on gauges and current draw. The current draw and pressures should go up. Place set point 0.5°C (0.9°F) above current box temperature to fully modulate valve, and run for approximately one minute.

NOTE

The unit may shut off for a short time. Wait until the unit self starts and sufficient time has elapsed to cause the valve to fully modulate. Record new gauge readings and current draw. The suction pressure should go into a vacuum and the current draw should have gone down. If little or no change to the suction pressure or current draw occurs, this is an indication of a malfunctioning SMV.

- j. Frozen operation: In frozen mode the valve tends to stay open as much as possible. Again, this is dependent upon current limit setting and control logic. Turn the unit OFF and ON, as in the perishable mode, and watch the gauges. The valve will run at 21% open if CREL logic is active, and will open to maximum allowable after this. Depending on ambient conditions, there should be an increase in suction pressure and current draw as the valve opens. However, at times, this may be difficult to fully determine.
- k. If the unit still does not operate properly, stop unit and proceed to the following step to check out the SMV system.

7.18 VALVE OVERRIDE CONTROLS

Cd41 is a configurable function code that allows manual operation of the SMV valve for troubleshooting. Test sequences are provided in [Table 7-1](#).

PCnt (% Setting – SMV Capacity Modulation) allows opening of the SMV to various percentages.

The Override Timer (tIM) selection is provided to enter a time period of up to five minutes, during which the override is active. If the timer is active, the valve override selection will take place immediately. If the timer is not active, changes will not take place for a few seconds after the timer is started. When the timer times out, override function is automatically terminated and the valve returns to normal machinery control. To operate the override, do the following:

- a. Press the CODE SELECT key then press an ARROW key until Cd41 is displayed in the left

window. The right window will display a controller communications code.

- b. Press the ENTER key. The left display will show a test name alternating with the test setting or time remaining. Use an ARROW key to scroll to the desired test. Press the ENTER key and SELCt will appear in the left display.
- c. Use an ARROW key to scroll to the desired setting, and then press the ENTER key. Selections are provided in the following table.
- d. If the timer is not operating, follow the above procedure to display the timer. Use an ARROW key to scroll to the desired time interval and press ENTER to start the timer.
- e. The above described sequence may be repeated during the timer cycle to change to another override.

Table 7-1 Valve Override Control Displays

| Left Display | Controller Communications Codes (Right Display) | Setting Codes (Right Display) |
|--------------|---|---|
| Cd 41/SELCt | tIM (Override Timer) | 0 00 (0 minutes/0 Seconds) In 30 second increments to 5 00 (5 minutes/ 0 seconds) |
| | PCnt (% Setting – SMV Capacity Modulation) | AutO (Normal Machinery Control) 0 3 6 10 25 50 100 |

7.18.1 Checking the Stepper Valve

- a. Checking with ohmmeter

Stop the unit, disconnect the 4-pin connector to the stepper SMV. With a reliable digital ohmmeter, check the winding resistance. In normal ambient, the valve should have 72 to 84 ohms measured on the red/green (a-b terminals) and on the white/black (c-d terminals) leads. If an infinite or zero reading occurs, check connections and replace the motor. If near normal or normal reading occurs, proceed to step 7.18.2 to check out the controller.

- b. Checking with SMA-12 portable stepper drive tester

The SMA-12 portable stepper drive tester (Carrier Transicold P/N 07-00375-00) is a battery-operated stepper drive that will open and close the SMV, allowing a more thorough check of the motor.

1. Stop the unit, disconnect the 4-pin connector from the stepper module to the valve (see [Figure 7.23](#)) and attach the SMA-12 stepper drive to the connector going to the valve.
2. Set the SMA-12 pulse per second (PPS) to one PPS and either open or close valve. Each LED should light sequentially until all four are lit. Any LED failing to light indicates an open on that leg,

which indicates a poor connection or an open coil. Repair or replace as required to achieve proper operation.

3. Restart unit, set the step rate to 200PPS on SMA-12 for the valve, and close stepper valve while watching the suction gauge. Within one minute the suction pressure will go into a vacuum. This is an indication that the valve is moving.
4. If no change in suction pressure is detected, check for resistance (refer to step 7.18.1), and check connections for proper continuity and retest. If the valve is functioning, and all connections and motor resistance are good, check the drive module (refer to step 7.18.2).
5. If the valve is determined to be faulty after completing the above steps, perform a low side pump down. Remove valve powerhead assembly, and replace with a NEW valve powerhead assembly, torque nut to 35ft-lb, evacuate low side, and open all service valves.



DO NOT disassemble piston from NEW suction modulating valve powerhead assembly. Doing so may result in damage to piston.

7.18.2 Checking the Controller

- a. Turn unit OFF.
- b. With voltmeter set to read 20 volts DC, attach the positive lead to MC1 of the 4-pin connector and the negative lead to the TP9. Turn ON unit and watch the volt meter. After a short delay, the reading should remain unchanged at 0 volts. If 5VDC, make sure the jumper wire from MC1 to MC8 is in place; if not, install and retest.

7.18.3 SMV Emergency Repair Procedure

In the event of an SMV failure, and replacement components are not readily available, the system can be bypassed by removing the SMV valve piston. To remove the piston, do the following:

- a. Perform a low side pump down (refer to [Section 7.4](#)).
- b. Remove SMV powerhead by loosening the 2-1/8 inch diameter nut (see [Figure 7.23](#)) to relieve any pressure and then sliding the powerhead out.
- c. Remove the piston by loosening the Allen screw and removing the piston and screw.
- d. Install the powerhead assembly (without the piston) and torque to 35 to 40ft-lbs.
- e. Open all valves.
- f. Start the unit.
- g. Adjust the suction service valve so that the approximate temperature OR current limit is maintained. For perishable loads, it is recommended that the adjustment be made so that the available capacity is slightly larger than the load. The unit will cycle OFF and ON.
- h. Once repair parts become available, repair as required.

7.19 AUTOTRANSFORMER

If the unit does not start, check the following:

- a. Make sure the 460VAC (yellow) power cable is plugged into the receptacle (item 3, [Figure 5.1](#)) and locked in place.
- b. Make sure circuit breakers CB-1 and CB-2 are in the "ON" position. If the circuit breakers do not hold in, check voltage supply.
- c. There is no internal protector for this transformer design; therefore, no checking of the internal protector is required.

- d. Using a voltmeter and with the primary supply circuit ON, check the primary (input) voltage (460VAC). Next, check the secondary (output) voltage (230VAC). The transformer is defective if output voltage is not available.

7.20 CONTROLLER

7.20.1 Handling Controller



Do not remove wire harnesses from controller unless you are grounded to the unit frame with a static safe wrist strap.



Unplug all controller connectors before performing arc welding on any part of the container.

The guidelines and cautions provided herein should be followed when handling the Controller/DataCORDER module. These precautions and procedures should be implemented when replacing the module, when doing any arc welding on the unit, or when service to the refrigeration unit requires handling and removal of the controller.

- a. Obtain a grounding wrist strap (Carrier Transicold P/N 07-00304-00) and a static dissipation mat (Carrier Transicold P/N 07-00304-00). The wrist strap, when properly grounded, will dissipate any potential electrostatic buildup on the body. The dissipation mat will provide a static-free work surface on which to place and/or service the controller.
- b. Disconnect and secure power to the unit.
- c. Place strap on wrist and attach the ground end to any exposed unpainted metal area on the refrigeration unit frame (bolts, screws, etc.).
- d. Carefully remove the controller, refer to [Section 7.20.4](#). Do not touch any of the electrical connections if possible. Place the module on the static mat.
- e. The strap should be worn during any service work on the controller, even when it is placed on the mat.

7.20.2 Controller Troubleshooting

A group of test points (TP) (see [Figure 7.24](#)) are provided on the controller for troubleshooting electrical circuits (see schematic diagram, [Section 8](#)). A description of the test points follows:

NOTE

Use a digital voltmeter to measure AC voltage between TPs and ground (TP9), except for TP8.

TP 1 – NA

TP 2 – This test point enables the user to check if the internal protector for the compressor motor (IP-CP) or high pressure switch is open.

TP 3 – This test point enables the user to check if the water pressure switch (WP) contact is open or closed.

TP 4 – This test point enables the user to check if the internal protector for the condenser fan motor (IP-CM) is open or closed.

TP 5 – This test point enables the user to check if the internal protectors for the evaporator fan motors (IP-EM1 or IP-EM2) are open or closed.

TP 6 – This test point enables the user to check if the controller water tank heater relay (TQ) is open or closed.

TP 7 – This test point is not used in this application.

TP 8 – This test point is not applicable to the units covered herein.

TP 9 – This test point is the chassis (unit frame) ground connection.

TP 10 – This test point enables the user to check if the heat termination thermostat (HTT) contact is open or closed.

Figure 7.24 Controller Section of the Control Box

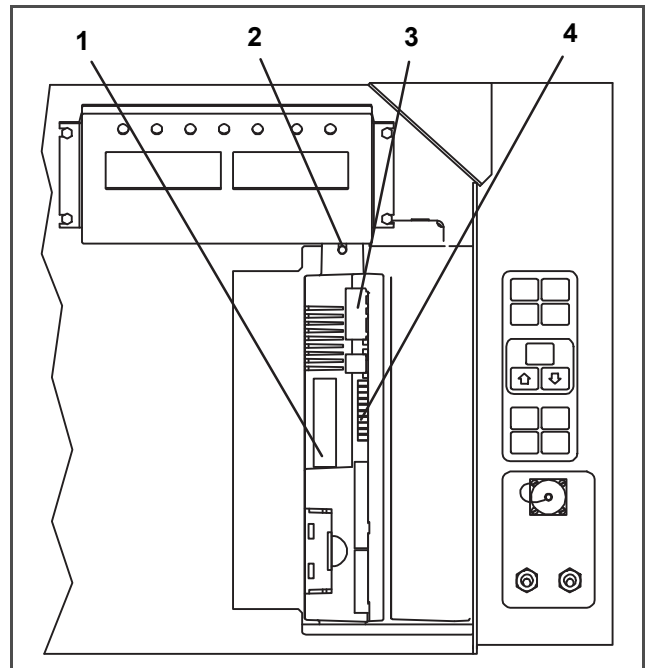

1. Controller Software Programming Port
2. Mounting Screw
3. Controller
4. Test Points

7.20.3 Controller Programming Procedure

To load new software into the module, the programming card (PCMIA) is inserted into the programming/software port.



The unit must be OFF whenever a programming card is inserted or removed from the controller programming port.

Loading operational software:

1. Turn unit OFF via start-stop switch (ST).
2. Insert software/programming card containing the following (example) files into the programming/software port (see [Figure 7.24](#)):

menuDDMM.ml3 – This file allows the user to select a file/program to upload into the controller.
cfYYMMDD.ml3 – Multi-configuration file.
3. Turn unit ON via start-stop switch (ST).
4. The display module will display the message ruN COnFG. If a defective card is being used, the display will blink the message “bAd CArd.” Turn start-stop switch OFF and remove the card.

5. Press the UP or DOWN arrow key until display reads, LOAd 51XX for Recip.
6. Press the ENTER key on the keypad. The display will alternate to between PrESS EntR and rEV XXXX.
7. Press the ENTER key on the keypad.
8. The display will show the message “Pro SoFt”. This message will last for up to one minute.
9. Press the ENTER key on the keypad.
10. The display module will go blank briefly, then read “Pro donE” when the software is loaded. If a problem occurs while loading the software, the display will blink the message “Pro FAIL” or “bad 12V.” Turn start-stop switch OFF and remove the card.
11. Turn unit OFF via start-stop switch (ST).
12. Remove the programming card from the programming/ software port and return the unit to normal operation by placing the start-stop switch in the ON position.
13. Turn power on and wait 15 seconds. The status LED will flash quickly and there will be no display. The controller is loading the new software into memory. This takes about 15 seconds.

When complete the controller will reset and power up normally.
14. Wait for default display – setpoint on the left and control temperature on the right.
15. Confirm software is correct using keypad code select 18 to view Cd18 XXXX.
16. Turn power off. Operational software is loaded.

Loading configuration software:

1. Turn unit OFF using start-stop switch (ST).
2. Insert software/programming PCMCIA card containing the following (example) files into the programming/ software port (see [Figure 7.24](#)):
menuDDMM.ml3 – This file allows the user to select the file/program to upload into the controller.
cfYMMDD.ml3 – Multi-configuration file.
recp54XX.ml3 – Controller software program for recip units.
3. Turn unit ON using start-stop switch (ST).
4. The display module will display the message ruN COnFG. If a defective card is being used, the display will blink the message “bAd CArd.” Turn start-stop switch OFF and remove the card.
5. Press the ENTER key on the keypad.
6. The display module will go blank briefly and then display “541 00.” Based on the operational software installed.

7. Press the UP or DOWN ARROW key to scroll through the list to obtain the proper model dash number. (If a defective card is being used, the display will blink the message “bAd CArd.” Turn start-stop switch OFF and remove the card.)
8. Press the ENTER key on the keypad.
9. When the software loading has successfully completed, the display will show the message “EEPrM donE.” (If a problem occurs while loading the software, the display will blink the message “Pro FAIL” or “bad 12V.” Turn start-stop switch OFF and remove the card.)
10. Turn unit OFF using start-stop switch (ST).
11. Remove the programming card from the programming/ software port and return the unit to normal operation by placing the start-stop switch in the ON position.
12. Confirm correct model configuration using the keypad to choose code select 20 (CD20). The model displayed should match the unit serial number plate.

7.20.4 Removing and Installing the Controller

Two different replacement controllers are available:

1. Re-manufactured – Controller is the equivalent of a new OEM controller and is supplied with a 12 month warranty.
2. Repaired – Controller has had previous faults repaired and upgraded with the latest software.

NOTE

Repaired controllers are NOT to be used for warranty repairs. Only full OEM re-manufactured controllers are to be used.

Replacement controllers will be factory equipped with the latest version of operational software, but will NOT be configured for a specific model number and will need to be configured at the time of installation or sale.

a. Removal:

1. Disconnect all front wire harness connectors and move wiring out of way.
2. The lower controller mounting is slotted. Loosen the top mounting screw (see [Figure 7.24](#)) and lift up and out.
3. Disconnect the two back connectors (EC) and remove module.
4. When removing the replacement controller from its packaging, note how it is packaged. When returning the old controller for service, place it in the packaging in the same manner as the replacement. The packaging has been designed to protect the controller from both physical and electrostatic discharge damage during storage and transit.

b. Installation:

Install the module by reversing the removal steps.

Torque values for mounting screws (item 2, see [Figure 7.24](#)) are 0.23mkg (20 inch-pounds). Torque value for the connectors is 0.12mkg (10 inch-pounds).

7.20.5 Battery Replacement

Standard Battery Location (Standard Cells):

- Turn unit power OFF and disconnect power supply.
- Slide bracket out and remove old batteries. (See [Figure 4.4](#), Item 8.)
- Install new batteries and slide bracket into control box slot.



Use care when cutting wire ties to avoid nicking or cutting wires.

Standard Battery Location (Rechargeable Cells):

- Turn unit power OFF and disconnect power supply.
- Disconnect battery wire connector from control box.
- Slide out and remove old battery and bracket. (See [Figure 4.4](#), Item 8.)
- Slide new battery pack and bracket into the control box slot.
- Reconnect battery wire connector to control box and replace wire ties that were removed.

Secure Battery Option (Rechargeable Cells Only):

- Turn unit power OFF and disconnect power supply.
- Open control box door and remove both the high voltage shield and clear plastic rain shield (if installed).
- Disconnect the battery wires from the “KA” plug positions 14, 13, 11.
- Using Driver Bit, Carrier Transicold part number 07-00418-00, remove the 4 screws securing the display module to the control box. Disconnect the ribbon cable and set the display module aside.

NOTE

The battery wires must face toward the right.

- Remove the old battery from the bracket and clean bracket surface. Remove the protective backing from the new battery and assemble to the bracket. Secure battery by inserting the wire tie from the back of the bracket around the battery, and back through the bracket.
- Reconnect the ribbon cable to display and re-install the display.

- Route the battery wires from the battery along the display harness and connect the red battery wire and one end of the red jumper to “KA14,” the other end of the red jumper wire to “KA11,” and the black wire to “KA13.”
- Replace wire ties that were removed.

7.21 TEMPERATURE SENSOR SERVICE

Service procedures for service of the return recorder, return temperature, supply recorder, supply temperature, ambient, defrost temperature, compressor discharge and compressor suction temperature sensors are provided in the following sub paragraphs.

7.21.1 Sensor Checkout Procedure

To verify that accuracy of a temperature sensor:

- Remove the sensor from the bracket and place in a 0°C (32°F) ice-water bath. The ice-water bath is prepared by filling an insulated container (of sufficient size to completely immerse bulb) with ice cubes or chipped ice, then filling voids between ice with water and agitating until mixture reaches 0°C (32°F) measured on a laboratory thermometer.
- Start unit and check sensor reading on the control panel. The reading should be 0C (32F). If the reading is correct, reinstall sensor; if it is not, continue with the following:
- Turn unit OFF and disconnect power supply.
- Refer to [Section 7.20](#) and remove controller to gain access to the sensor plugs.
- Using the plug connector marked “EC,” that is connected to the back of the controller, locate the sensor wires (RRS, RTS, SRS, STS, AMBS, DTS, CPDS OR CPSS as required). Follow those wires to the connector and using the pins of the plug, measure the resistance. Values are provided in Table 7-2.

Table 7-2 Sensor Temperature/Resistance Chart

| Temperature Centigrade | Temperature Fahrenheit | Resistance (Ohms) |
|------------------------|------------------------|-----------------------|
| RRS, RTS, SRS and STS | | |
| 0 | 32 | 32,650 +/-91 |
| 25 | 77 | 10,000 +/-50 |
| AMBS and DTS | | |
| 0 | 32 | 32,650 +1720 -1620 |
| 25 | 77 | 10,000 +450 -430 |

Due to the variations and inaccuracies in ohmmeters, thermometers, or other test equipment, a reading within 2% of the chart value would indicate a good sen-

sor. If a sensor is defective, the resistance reading will usually be much higher or lower than the resistance values given.

7.21.2 Sensor Replacement

- a. Turn unit power OFF and disconnect power supply.
- b. For two wire sensors, cut cable 5cm (2 inches) from shoulder of defective sensor and discard the defective sensor only. For 3-wire sensors, cut at 23cm (9 inches). Slide the cap and grommet off well mounted sensor and save for possible reuse. Do not cut the grommet.
- c. If required, prepare the replacement sensor by cutting sensor wire(s) back 40mm (1-1/2 inch). For 3-wire sensors, the black wire should be cut at the middle length and the red/white wire cut to the shorter length (See [Figure 7.25](#)).

Figure 7.25 Sensor Types

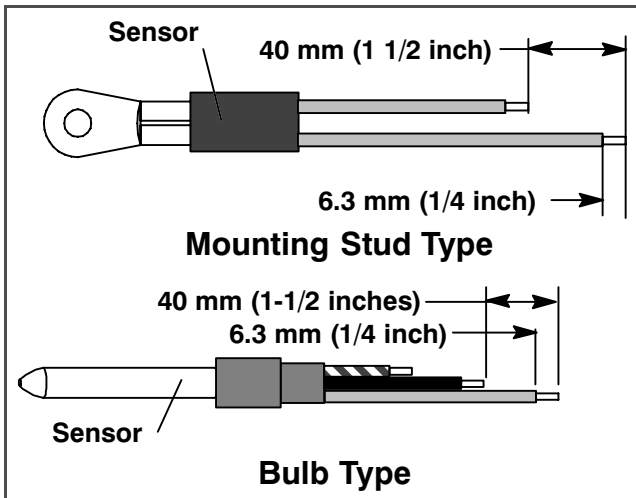

- d. Prepare the cables by cutting wires to the opposite of the sensor (See [Figure 7.26](#)).

When installing a single wire color two wire sensor, cut one wire of existing two wire cable 40mm (1-1/2 inch) shorter than the other wire.

When replacing two single sensors with a combination (3-wire) sensor, the black wires of the cables should be cut to the same length and the red wire of one cable cut to the shorter length.

When replacing an original 3-wire sensor, cut the black wire to the middle length and the red wire to the shorter length.

- e. Strip back insulation on all wiring 6.3mm (1/4 inch).
- f. Slide a large piece of heat shrink tubing over the cable, and place small pieces of heat shrink tubing, one over each wire, before adding crimp fittings as shown in [Figure 7.26](#).
- g. If required, slide the cap and grommet assembly onto the replacement sensor. If the replacement sensor is of a larger diameter than the original, a different grommet may be required.
- h. Slip crimp fittings over dressed wires (keeping wire colors together). Make sure wires are pushed into crimp fittings as far as possible and crimp with crimping tool.
- i. Solder spliced wires with a 60% tin and 40% lead Rosincore solder.
- j. Slide heat shrink tubing over splice so that ends of tubing cover both ends of crimp as shown in [Figure 7.26](#).
- k. Heat tubing to shrink over splice. Make sure all seams are sealed tightly against the wiring to prevent moisture seepage.
- l. Slide large heat shrink tubing over both splices and shrink.

CAUTION

Do not allow moisture to enter wire splice area as this may affect sensor resistance.
 m. Reinstall sensor, refer to [Section 7.21.3](#).

NOTE

The P5 Pre-Trip test must be run to inactivate probe alarms (refer to [Section 5.8](#)).

Figure 7.26 Sensor and Cable Splice

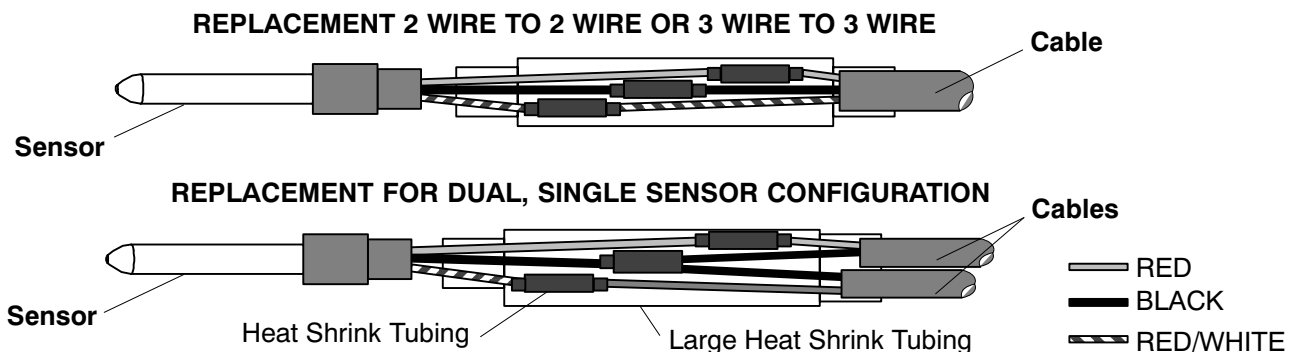

7.21.3 Sensor Re-Installation

a. Sensors STS/SRS

To properly position a supply sensor, the sensor must be fully inserted into the probe holder. This positioning will give the sensor the optimum amount of exposure to the supply air stream, and will allow the Controller to operate correctly. Insufficient probe insertion into the probe holder will result in poor temperature control due to the lack of air flow over the sensor.

It is also necessary to ensure that the probe tip does not contact the evaporator back panel. The design minimum clearance of 6mm (1/4 inch) should be maintained (see [Figure 7.27](#)).

b. Sensor RTS/RRS

Reinstall the return sensor as shown in [Figure 7.28](#). For proper placement of the return sensor, be sure to position the seal section of the sensor against the side of the mounting clamp.

c. Sensor DTS

The DTS sensor must have insulating material placed completely over the sensor to insure the coil metal temperature is sensed.

Figure 7.27 Supply Sensor Positioning

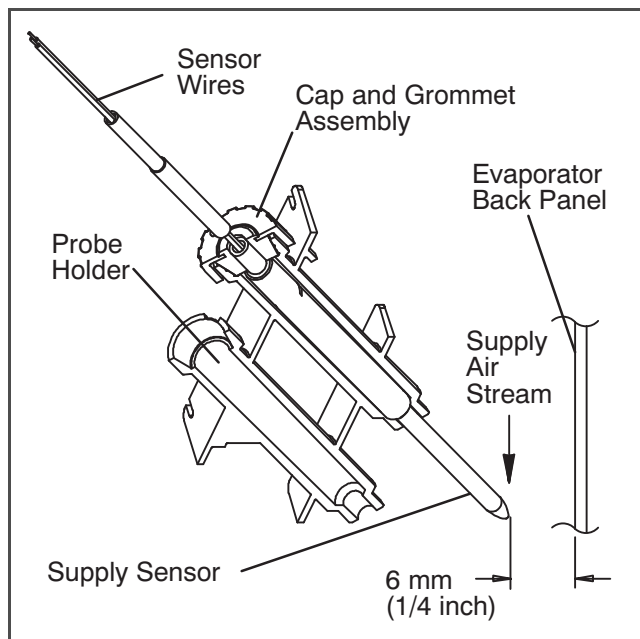
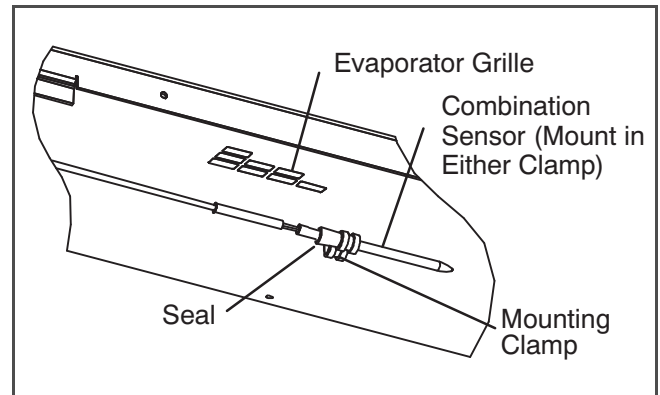

Figure 7.28 Return Sensor Positioning



7.22 VENT POSITION SENSOR (VPS)

The vent position sensor (VPS) determines the position of the fresh air vent in near real-time via the Cd45.

The fresh air VPS alarm (AL50) will occur if the sensor reading is not stable for five minutes or if the sensor is outside of its valid range (shorted or open). This can occur if the vent is loose or the panel is defective. To confirm a defective panel, assure that the wing nut is secure and then power cycle the unit.

The alarm should immediately go inactive. Check the four-minute stability requirement. If the alarm reoccurs after the four minutes and the panel was known to have been stable, then the panel should be replaced.

If the alarm immediately reappears as active, the panel should be replaced.

VPS:

In order to replace the VPS, the panel must be removed and replaced with another upper fresh air panel equipped with VPS.

Upon installation, a new VPS assembly requires calibration as follows:

1. Rotate the vent to the 0CMH/CFM position.
2. Code select Cd45 will automatically be displayed. Press the Enter key and hold for five seconds.
3. After the enter key has been pressed, the display will read CAL (for calibration).
4. Press the ALT MODE key and hold for five seconds.
5. After the calibration has been completed, Cd45 will display 0 CMH / CFM.

7.23 EAUTOFRESH SERVICE

7.23.1 Servicing the eAutoFresh Air Filter

Removing the Air Sample Filter Element

The air sample filter element can be accessed in two ways:

1. Through the eAutoFresh side evaporator access panel (see [Figure 3.2](#)).
2. Through the inside of the container by lowering the upper evaporator panel.
 - a. By hand, unscrew and remove the filter cup from the bottom of the air sample filter assembly.
 - b. Remove the filter element from the filter assembly.
 - c. Install the new air sample filter element by reversing the above steps.

7.23.2 Checking eAutoFresh Drive System

Checking the Auto Slide:

- a. To check with an ohmmeter, disconnect the four pin connector to the stepper motor. With a reliable digital ohmmeter, check the winding resistance. In normal ambient, the motor should have 72 to 84 ohms measured on the red/green (a-b terminals) and on the white/black (c-d terminals) leads. If an infinite or zero reading occurs, check connections or replace the motor. If near normal or normal reading occurs, proceed to Checking the Controller.
- b. To check with a SMA-12 portable stepper drive tester. The SMA-12 portable stepper drive tester (Carrier Transicold P/N 07-00375-00) is a battery operated stepper drive which will open and close the auto slide, which allows a more thorough check of the motor.

Checking the Slide Motor:

- a. Turn unit OFF.
- b. Disconnect the four pin connector from the Stepper Drive to the Stepper Motor, (see [Figure 7.23](#)).
- c. Attach the SMA-12 portable stepper drive tester to the Stepper Motor.

Figure 7.29 Stepper Components

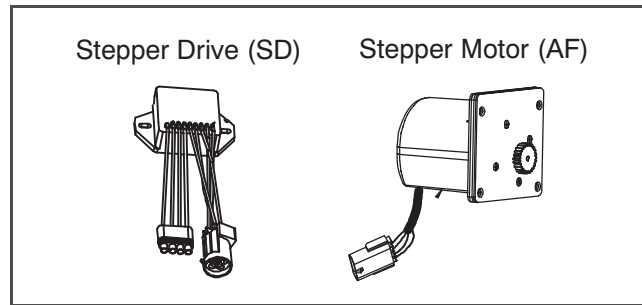

- d. Set the SMA-12 pulse per second (PPS) to one PPS and press button to open or close the valve. Each LED should light sequentially until all four are lit. If an LED fails to light, it indicates an open on that leg caused by a poor connection or an open coil. Repair or replace as required to achieve proper operation.
- e. Set the SMA-12 step rate to 200 PPS. Press open or close while watching the slide mechanism for movement, this is an indication that the motor is working.
- f. If the slide moves using the SMA-12, but fails to move when connected in the unit (refer to "Checking the Drive Module" in the section that follows.)

Checking the Drive Module:

- a. Turn unit OFF.
- b. Disconnect the four pin connector to the Stepper Motor.
- c. With a voltmeter set to read 24 volts AC, attach the positive lead to the drive module outlet pin A (wire 1A) of the four pin connector and the negative lead to the B pin (wire 1B).
- d. Turn ON unit, and watch the volt meter. After a short delay, the reading should rise to approximately 12 volts.
- e. Repeat for pins C and D (wires 2A and 2B).
- f. If only one set of pins reads a voltage, check connections and retest.
- g. If the retest reads out the same, the drive module or controller is faulty.
- h. If no voltage is present in any step, the output from the controller to the drive module may be faulty. Check the connections and wires from the controller to the drive module.
- i. To replace the drive module, disconnect all connectors, unscrew from mounting, and replace with a NEW drive module in reverse order.

Checking the Controller:

- a. Turn the unit OFF.
- b. Disconnect the six pin connector to the stepper drive from the controller.
- c. With a voltmeter set to read 50 volts DC, attach the positive lead to outlet pin A of the six pin connector, and the negative lead to pin B or TP-9 of the controller.
- d. Turn ON the unit for 40 seconds, and watch the voltmeter. There should be approximately 24 to 32 VDC shown on pin A.
- e. There should be zero volts on pin B.
- f. After a short delay, the reading should rise to approximately 24 to 32 VDC on pin E.
- g. Pins C and D will have zero to 5 volts transistor logic (TTL) signals present, however, this can only be checked with the connector assembled as this is an open collector type circuit.

Checking the outputs on A, B and E will verify that the controller is supplying power to the drive module. To be thorough, and if it is desired, the signals on pins C and D can be checked as follows:

- h. Install a jumper assembly (Carrier part number 07-00408-00) to connect the drive module and controller connectors as shown in [Figure 7.30](#).
- i. Connect the positive lead of the voltmeter to test connector socket C and negative lead to socket B, and run as before by resetting unit.
- j. Repeat for sockets D and B.

Figure 7.30 Jumper Assembly

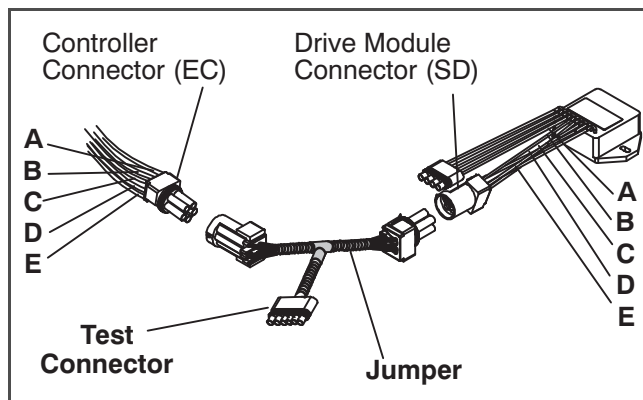

There should be approximately five volts DC on sockets "C" and "D" (S1 and S2) when measured as above. If not the connections or controller is faulty. If any of these pins are not consistent, the connections or the controller is suspect. Check and replace as required.

7.23.3 Servicing the eAutoFresh Drive System

To replace the Drive Motor Assembly:

- a. Remove the bolts that secure the eAutoFresh Panel (3, [Figure 7.31](#)) to the front of the unit. Reach in, cut tie wrap, (2) and disconnect the motor connector (1). Bring panel to work area.
- b. Remove four screws (8) fastening the grille (7).
- c. Remove six screws (9) fastening the rails (5 and 11), the slide plate (10) and the gasket plate (6). Set components aside for reassembly.
- d. Remove the four screws (12) fastening the motor cup (4) to the panel. Cut sealer on outside and inside of motor cup assembly. Push out the motor cup assembly from the rear of the panel.
- e. Mount the replacement motor cup assembly in the panel using original screws. Torque screws to 0.29 mkg (25 +/- 1 Inch pounds).
- f. Reapply sealer to the inside and the outside of the motor cup assembly.
- g. Mount the upper & lower rails, slide plate and gasket plate using original hardware. Apply thread sealant and torque screws to 0.29 mkg (25 +/- 1 Inch pounds).
- h. Mount grille assembly using original hardware. Apply thread sealant and torque screws to 0.29 mkg (25 +/- 1 Inch pounds).
- i. Reconnect the motor connector.
- j. Replace the bolts that secure the eAutoFresh Panel to the front of the unit.
- k. Carry out functional test. Refer to [Section 5.4.3](#) step c.

Figure 7.31 Motor Cup Replacement

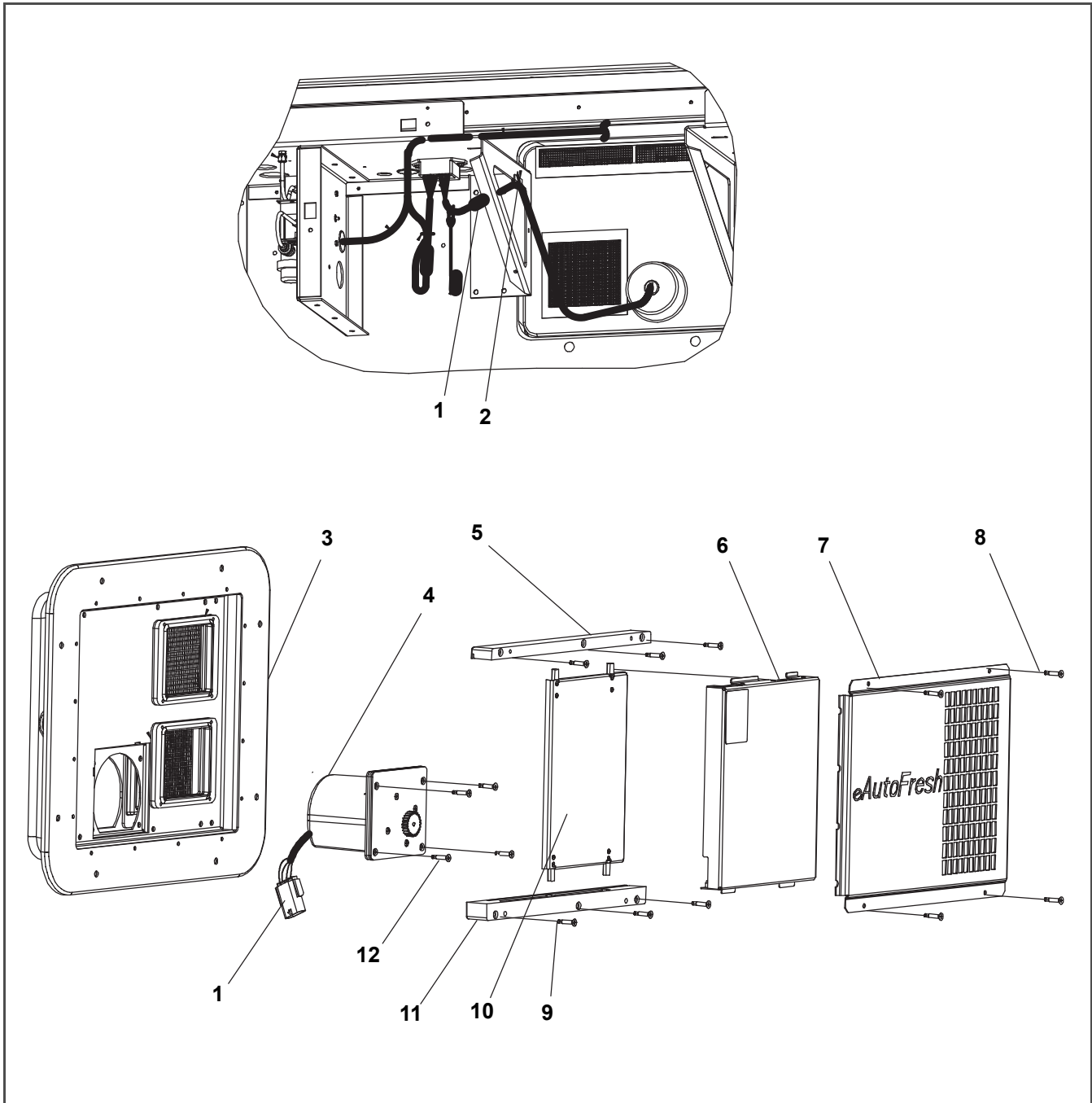

- | | |
|---------------------|----------------------|
| 1. Connector | 7. Grille |
| 2. Tie Wrap | 8. Grill Screws |
| 3. eAutoFresh Panel | 9. Rail Screws |
| 4. Cup, Motor | 10. Plate, Slide |
| 5. Rail, Top | 11. Rail, Bottom |
| 6. Plate, Gasket | 12. Motor Cup Screws |

7.24 MAINTENANCE OF PAINTED SURFACES

The refrigeration unit is protected by a special paint system against the corrosive atmosphere in which it normally operates. However, should the paint system be damaged, the base metal can corrode. In order to protect the refrigeration unit from the highly corrosive sea atmosphere or if the protective paint system is scratched or damaged, clean area to bare metal using a wire brush, emery paper, or equivalent cleaning method. Immediately following cleaning, spray or brush on zinc-rich primer. After the primer has dried, spray or brush on finish coat of paint to match original unit color.

7.25 COMMUNICATIONS INTERFACE MODULE INSTALLATION

Figure 7.32 Communications Interface Installation

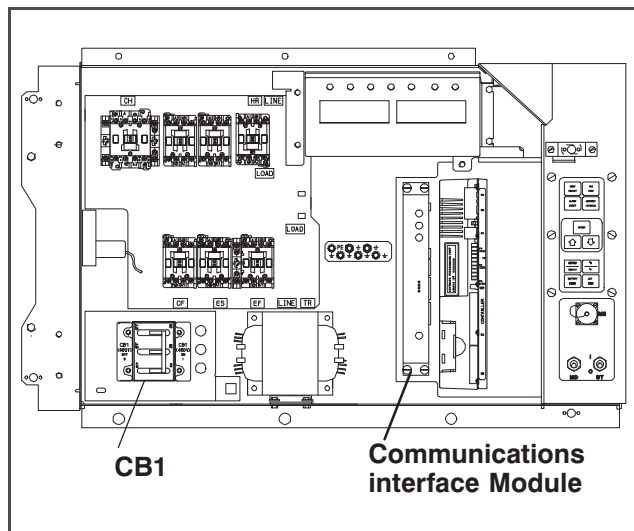

Units with communication interface module provision have the required wiring installed. The provision wiring kit (part number 76-00685-00), includes three pre-addressed wires installed between the circuit breaker and communication interface module locations. These wires are to be connected to the module and circuit breaker to allow the module to communicate over the power system. To install the module, do the following:

WARNING

The unit power plug must be disconnected to remove power from circuit breaker CB1

- CB1 is connected to the power system, see wiring schematic. Ensure that the unit power is off AND that the unit power plug is disconnected.
- Open control box, see [Figure 7.32](#) and remove low voltage shield. Open high voltage shield.
- Remove the circuit breaker panel, with circuit breaker, from the control box.
- Locate wires CB21/CIA3, CB22/CIA5 and CB23/CIA7 that have been tied back in the wire harness. Remove the protective heat shrink from the ends of the wires.
- Attach the three wires as addressed to the LOAD side of the circuit breaker.
- Refit the circuit breaker panel.
- Fit the new RMU into the unit.
- Remove plugs CIA, CIB and CID from the wiring harness and attach to the module.
- Replace the low voltage shield.

Table 7-3 Recommended Bolt Torque Values

| BOLT DIA. | THREADS | TORQUE | N.m |
|---|---------|-------------|-------|
| Free Spinning | | | |
| #4 | 40 | 5.2in-lbs | .6 |
| #6 | 32 | 9.6in-lbs | 1.0 |
| #8 | 32 | 20in-lbs | 2.25 |
| #10 | 24 | 23in-lbs | 2.6 |
| 1/4 | 20 | 75in-lbs | 8.4 |
| 5/16 | 18 | 11ft-lbs | 1.52 |
| 3/8 | 16 | 20ft-lbs | 2.76 |
| 7/16 | 14 | 31ft-lbs | 4.28 |
| 1/2 | 13 | 43ft-lbs | 5.94 |
| 9/16 | 12 | 57ft-lbs | 7.88 |
| 5/8 | 11 | 92ft-lbs | 12.72 |
| 3/4 | 10 | 124ft-lbs | 17.14 |
| Nonfree Spinning (Locknuts etc.) | | | |
| 1/4 | 20 | 82.5in-lbs | 9.3 |
| 5/16 | 18 | 145.2in-lbs | 16.4 |
| 3/8 | 16 | 22.0ft-lbs | 30 |
| 7/16 | 14 | 34.1ft-lbs | 46 |
| 1/2 | 13 | 47.3ft-lbs | 64 |
| 9/16 | 12 | 62.7ft-lbs | 85 |
| 5/8 | 11 | 101.2ft-lbs | 137 |
| 3/4 | 10 | 136.4ft-lbs | 168 |

Table 7-4 Wear Limits For Compressors

| PART NAME | FACTORY MAXIMUM | | FACTORY MINIMUM | | MAXIMUM WEAR BEFORE REPAIR | |
|-------------------------------|-----------------|---------|-----------------|---------|----------------------------|--------|
| | inches | mm | inches | mm | inches | mm |
| MAIN BEARING | | | | | | |
| Main Bearing Diameter | 1.6268 | 41.3207 | | | .0020 | 0.0508 |
| Main Bearing Journal Diameter | | | 1.6233 | 41.2318 | .0020 | 0.0508 |
| PUMP END | | | | | | |
| Main Bearing Diameter | 1.3760 | 34.9504 | | | .0020 | 0.0508 |
| Main Bearing Journal Diameter | | | 1.3735 | 34.8869 | .0020 | 0.0508 |
| CONNECTING ROD | 1.3768 | 34.9707 | | | .0020 | 0.0508 |
| Piston Pin Bearing | | | 0.6878 | 17.4701 | .0010 | 0.0254 |
| CRANKPIN DIAMETER | | | 1.3735 | 34.8869 | .0025 | 0.0635 |
| Throw | 1.072 | 27.2288 | 1.070 | 27.1780 | | |
| THRUST WASHER (Thickness) | 0.154 | 3.9116 | 0.1520 | 03.8608 | .0250 | 0.6350 |
| CYLINDERS | | | | | | |
| Bore | 2.0010 | 50.8254 | | | .0020 | 0.0508 |
| Piston (Diameter) | | | 1.9860 | 50.4444 | .0020 | 0.0508 |
| Piston Pin (Diameter) | | | 0.6873 | 17.4574 | .0010 | 0.0254 |
| Piston Ring Gap | 0.013 | 00.3302 | 0.0050 | 00.1270 | .0250 | 0.6350 |
| Piston Ring Side Clearance | 0.002 | 00.0508 | 0.0010 | 00.0254 | .0020 | 0.0508 |

Table 7-5 Compressor Torque Values

| SIZE DIAMETER (inches) | THREADS PER INCH | TORQUE RANGE | | USAGE |
|------------------------------|---------------------|--------------|----------|--|
| | | ft-lb | N.m | |
| 1/16 | 27 (pipe) | 8 – 12 | 11 – 16 | Pipe Plug - Crankshaft |
| 1/8 | 20 (pipe) | 6 – 10 | 8 – 13 | Oil Return Check Valve – Crankcase |
| 1/4 | 20 (pipe) | 20 – 25 | 27 – 34 | Pipe Plug – Gauge Connection |
| 1/4 | 20 | 10 – 12 | 13 – 16 | Connecting Rod cap screw |
| 1/4 | 28 | 12 – 15 | 16 – 20 | Baffle Plate - Crankcase |
| | | 12 – 16 | 16 – 22 | Side Shield |
| | | 6 – 10 | 8 – 13 | Oil Pump Drive Segment |
| | | 12 – 16 | 16 – 22 | Unloader Valve |
| 5/16 | 18 | 16 – 20 | 2 – 27 | Cover Plate – Plate End |
| | | | | Bearing Head |
| | | | | Terminal Block Cap Screws |
| | | 20 – 30 | 27 – 41 | Suction Valve |
| | | | | Discharge Valve |
| 3/8 | 16 | 40 – 50 | 55 – 70 | Pump End Bearing Head |
| | | | | Bottom Plate – Crankcase Compressor Foot |
| | | | | Cylinder Head |
| 7/16 | 14 | 55 – 60 | 76 – 83 | Motor End Cover – Crankcase |
| 5/8 | 11 | 25 – 30 | 34 – 41 | Crankshaft |
| 5/8 | 18 | 60 – 75 | 83 – 103 | Oil Bypass Plug – Crankcase |
| #10 | 32 | 4 – 6 | 5 – 8 | Oil Pump Drive Segment |
| 1-1/2 | 18 NEF | 35 – 45 | 48 – 62 | Oil Level Sight Glass |
| NEF – National Extra Fine | | | | |

Table 7-6 R-134a Temperature - Pressure Chart

| Temperature | | Vacuum | | | |
|-------------|-----|----------|-------|--------------------|------|
| F | C | "/hg | cm/hg | kg/cm ² | bar |
| -40 | -40 | 14.6 | 49.4 | 37.08 | 0.49 |
| -35 | -37 | 12.3 | 41.6 | 31.25 | 0.42 |
| -30 | -34 | 9.7 | 32.8 | 24.64 | 0.33 |
| -25 | -32 | 6.7 | 22.7 | 17.00 | 0.23 |
| -20 | -29 | 3.5 | 11.9 | 8.89 | 0.12 |
| -18 | -28 | 2.1 | 7.1 | 5.33 | 0.07 |
| -16 | -27 | 0.6 | 2.0 | 1.52 | 0.02 |
| Temperature | | Pressure | | | |
| F | C | psig | kPa | kg/cm ² | bar |
| -14 | -26 | 0.4 | 1.1 | 0.03 | 0.03 |
| -12 | -24 | 1.2 | 8.3 | 0.08 | 0.08 |
| -10 | -23 | 2.0 | 13.8 | 0.14 | 0.14 |
| -8 | -22 | 2.9 | 20.0 | 0.20 | 0.20 |
| -6 | -21 | 3.7 | 25.5 | 0.26 | 0.26 |
| -4 | -20 | 4.6 | 31.7 | 0.32 | 0.32 |
| -2 | -19 | 5.6 | 36.6 | 0.39 | 0.39 |
| 0 | -18 | 6.5 | 44.8 | 0.46 | 0.45 |
| 2 | -17 | 7.6 | 52.4 | 0.53 | 0.52 |
| 4 | -16 | 8.6 | 59.3 | 0.60 | 0.59 |
| 6 | -14 | 9.7 | 66.9 | 0.68 | 0.67 |
| 8 | -13 | 10.8 | 74.5 | 0.76 | 0.74 |
| 10 | -12 | 12.0 | 82.7 | 0.84 | 0.83 |
| 12 | -11 | 13.2 | 91.0 | 0.93 | 0.91 |
| 14 | -10 | 14.5 | 100.0 | 1.02 | 1.00 |
| 16 | -9 | 15.8 | 108.9 | 1.11 | 1.09 |
| 18 | -8 | 17.1 | 117.9 | 1.20 | 1.18 |
| 20 | -7 | 18.5 | 127.6 | 1.30 | 1.28 |
| 22 | -6 | 19.9 | 137.2 | 1.40 | 1.37 |
| 24 | -4 | 21.4 | 147.6 | 1.50 | 1.48 |
| 26 | -3 | 22.9 | 157.9 | 1.61 | 1.58 |

| Temperature | | Pressure | | | |
|-------------|----|----------|-------|--------------------|-------|
| F | C | psig | kPa | kg/cm ² | bar |
| 28 | -2 | 24.5 | 168.9 | 1.72 | 1.69 |
| 30 | -1 | 26.1 | 180.0 | 1.84 | 1.80 |
| 32 | 0 | 27.8 | 191.7 | 1.95 | 1.92 |
| 34 | 1 | 29.6 | 204.1 | 2.08 | 2.04 |
| 36 | 2 | 31.3 | 215.8 | 2.20 | 2.16 |
| 38 | 3 | 33.2 | 228.9 | 2.33 | 2.29 |
| 40 | 4 | 35.1 | 242.0 | 2.47 | 2.42 |
| 45 | 7 | 40.1 | 276.5 | 2.82 | 2.76 |
| 50 | 10 | 45.5 | 313.7 | 3.20 | 3.14 |
| 55 | 13 | 51.2 | 353.0 | 3.60 | 3.53 |
| 60 | 16 | 57.4 | 395.8 | 4.04 | 3.96 |
| 65 | 18 | 64.1 | 441.0 | 4.51 | 4.42 |
| 70 | 21 | 71.1 | 490.2 | 5.00 | 4.90 |
| 75 | 24 | 78.7 | 542.6 | 5.53 | 5.43 |
| 80 | 27 | 86.7 | 597.8 | 6.10 | 5.98 |
| 85 | 29 | 95.3 | 657.1 | 6.70 | 6.57 |
| 90 | 32 | 104.3 | 719.1 | 7.33 | 7.19 |
| 95 | 35 | 114.0 | 786.0 | 8.01 | 7.86 |
| 100 | 38 | 124.2 | 856.4 | 8.73 | 8.56 |
| 105 | 41 | 135.0 | 930.8 | 9.49 | 9.31 |
| 110 | 43 | 146.4 | 1009 | 10.29 | 10.09 |
| 115 | 46 | 158.4 | 1092 | 11.14 | 10.92 |
| 120 | 49 | 171.2 | 1180 | 12.04 | 11.80 |
| 125 | 52 | 184.6 | 1273 | 12.98 | 12.73 |
| 130 | 54 | 198.7 | 1370 | 13.97 | 13.70 |
| 135 | 57 | 213.6 | 1473 | 15.02 | 14.73 |
| 140 | 60 | 229.2 | 1580 | 16.11 | 15.80 |
| 145 | 63 | 245.6 | 1693 | 17.27 | 16.93 |
| 150 | 66 | 262.9 | 1813 | 18.48 | 18.13 |
| 155 | 68 | 281.1 | 1938 | 19.76 | 19.37 |

Figure 7.33 R-134a Compressor Pressure and Motor Current Curves Vs. Ambient Temperature, Sheet 1

Note: Curves to be used as troubleshooting guide only for model series 69NT40 with fresh air makeup vent closed, unit powered on 460VAC/60Hz and SMV 100% open.

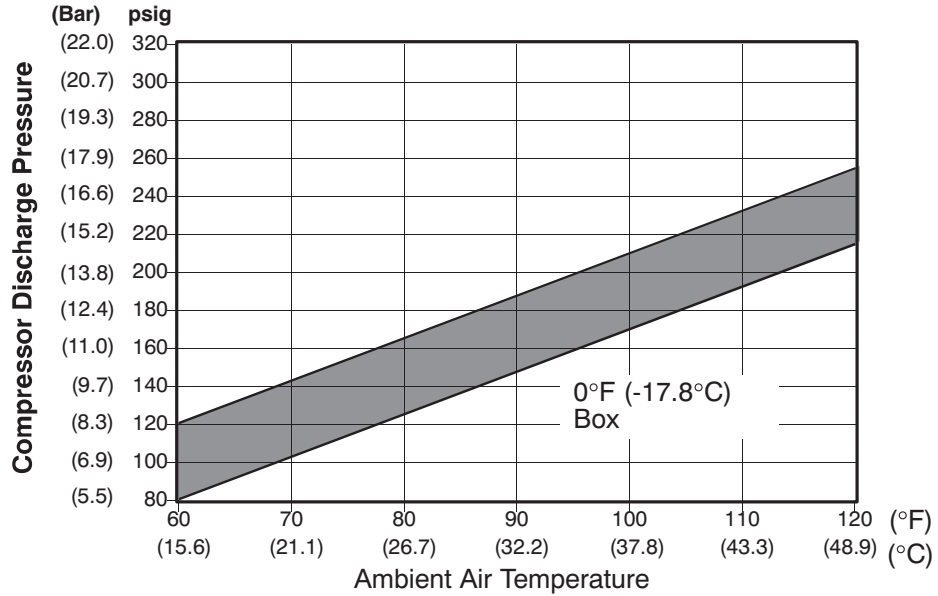
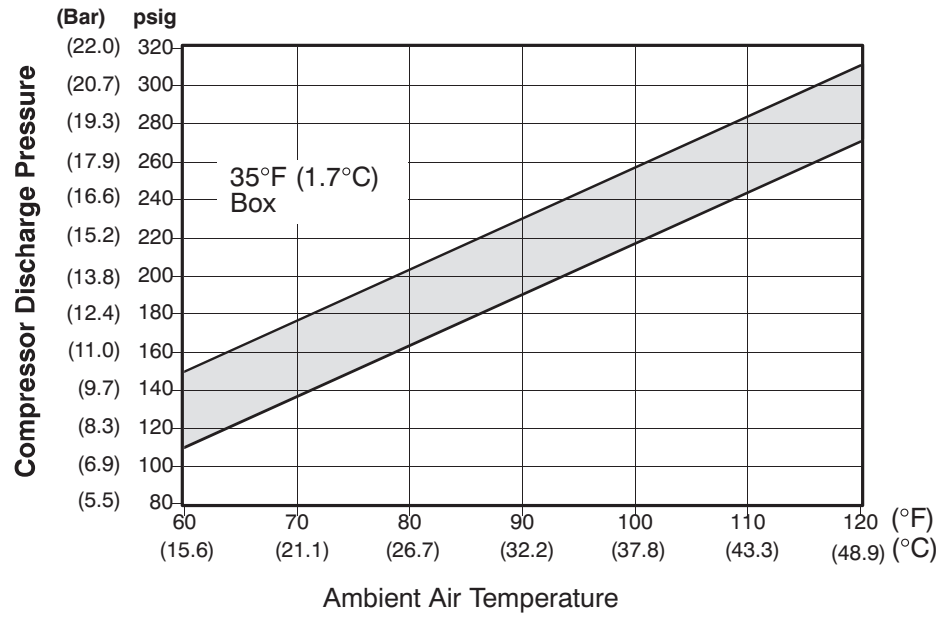

Compressor Discharge Pressure Versus Ambient Air Temperature at Stable Box Temperature

Figure 7.34 R-134a Compressor Pressure and Motor Current Curves Vs. Ambient Temperature, Sheet 2

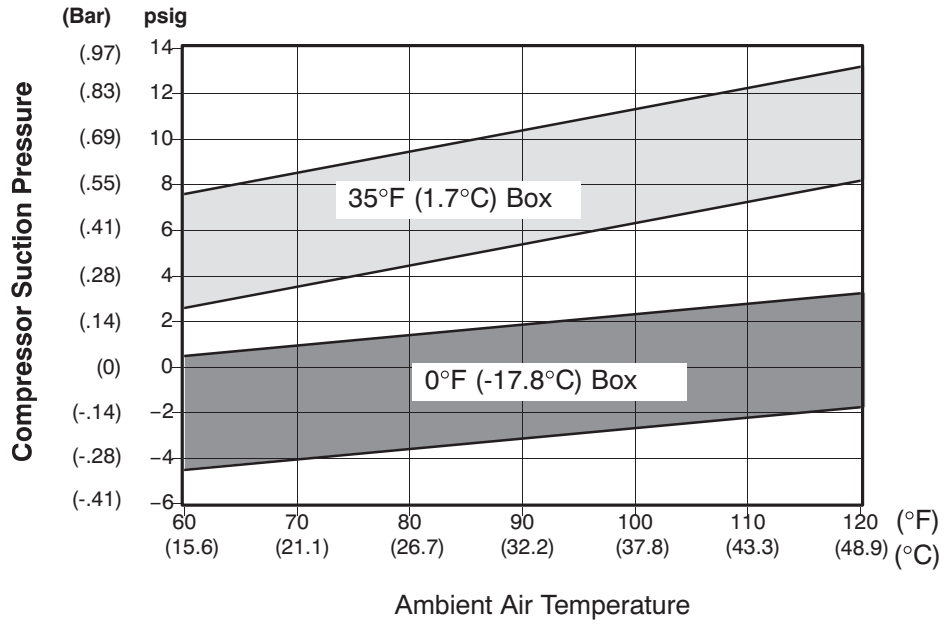

Compressor Suction Pressure Versus Ambient Air Temperature at Stable Box Temperature

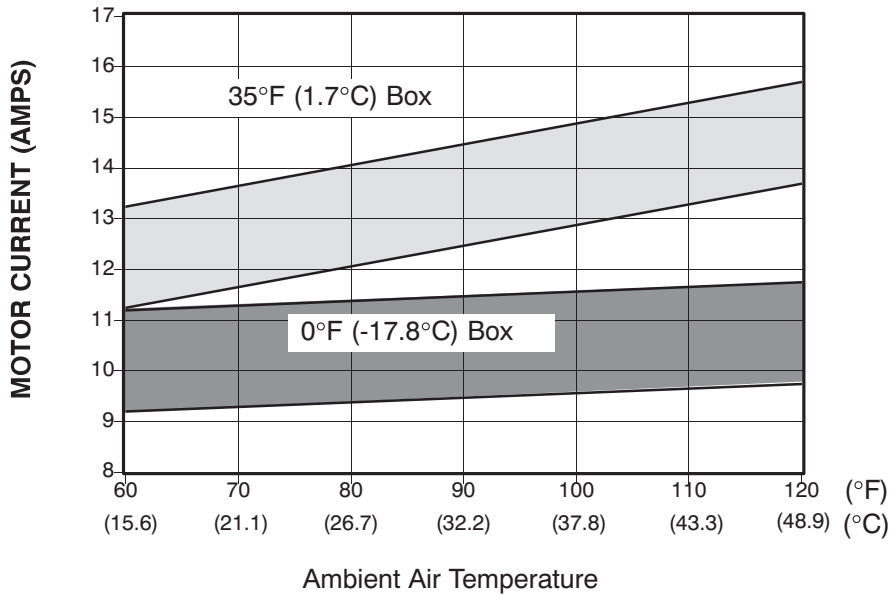

Compressor-Motor Current Versus Ambient Air Temperature At Stable Box Temperature

SECTION 8

ELECTRICAL WIRING SCHEMATIC AND DIAGRAMS

8.1 INTRODUCTION

This section contains the Electrical Schematics and Wiring Diagrams.

Figure 8.1 LEGEND

LEGEND

| SYMBOL DESCRIPTION | SYMBOL DESCRIPTION |
|--|--|
| AMBS AMBIENT SENSOR (D-22) | IC INTERROGATOR CONNECTOR (OPTION) (T-23) |
| C CONTROLLER (C-21) | IP INTERNAL PROTECTOR (E-10, E-13, G-13, G-12) |
| CB1 CIRCUIT BREAKER – 460 VOLT (K-1) | IRL IN-RANGE LIGHT (OPTION) (M-16) |
| CB2 OPTIONAL CIRCUIT BREAKER 230V (DVM OPTION) | PA CONTACTOR (K-9, L-8, R-6) |
| TERMINAL BLOCK WHEN CB2 NOT PRESENT (D-1) | PB CONTACTOR (K-8, L-9, R-7) |
| CF CONDENSER FAN CONTACTOR (L-11, N-9) | PR PROBE RECEPTACLE |
| CI COMMUNICATIONS INTERFACE MODULE (OPTION) | (USDA OPTION) (F-22, M-23, N-23, P-23) |
| (A-4) | PTC1 PTC FOR VENT POSITION SENSOR (UPPER) (N-19) |
| CH COMPRESSOR CONTACTOR (L-10, R-1) | RM REMOTE MONITORING RECEPTACLE (OPTION) |
| C-L COOL LIGHT (OPTION) (L-14) | (L-13, K-13, K-16, L-16) |
| CM CONDENSER FAN MOTOR (G-11, R-10) | RRS RETURN RECORDER SENSOR (OPTION) (C-22) |
| CP COMPRESSOR MOTOR (E-10, T-2) | RTS RETURN TEMPERATURE SENSOR (C-22) |
| CPDS COMPRESSOR DISCHARGE SENSOR (TEMP) (B-22) | SMV STEPPER MOTOR SUCTION MODULATION |
| CPSS COMPRESSOR SUCTION SENSOR (TEMP) | VALVE (T-18) |
| (OPTION), E-22 | SPT SUCTION PRESSURE TRANSDUCER |
| CPT CONDENSER PRESSURE TRANSDUCER (H-23) | (OPTION) (J-23) |
| CS CURRENT SENSOR (M-2) | SRS SUPPLY RECORDER SENSOR (L-23) |
| DHBL DEFROST HEATER – BOTTOM LEFT (R-5) | ST START – STOP SWITCH (K-5) |
| DHBR DEFROST HEATER – BOTTOM RIGHT (T-4) | STS SUPPLY TEMPERATURE SENSOR (A-22) |
| DHML DEFROST HEATER – MIDDLE LEFT (R-4) | TC CONTROLLER RELAY–COOLING (K-10) |
| DHMR DEFROST HEATER – MIDDLE RIGHT (T-3) | TCP CONTROLLER RELAY – COMPRESSOR PHASE |
| DHTL DEFROST HEATER – TOP LEFT (R-3) | SEQUENCING (K-8, K-9) |
| DHTR DEFROST HEATER – TOP RIGHT (T-5) | TCC TRANSFRESH COMMUNICATIONS CONNECTOR |
| DL DEFROST LIGHT (OPTION) (L-8) | (OPTION) (E-7) |
| DPT DISCHARGE PRESSURE TRANSDUCER | TE CONTROLLER RELAY – HIGH SPEED EVAPORATOR |
| (OPTION) (K-23) | FANS (K-12) |
| DTS DEFROST TEMPERATURE SENSOR (C-22) | TH CONTROLLER RELAY – HEATING (K-14) |
| DVM DUAL VOLTAGE MODULE (OPTION) (E-1) | TI CONTROLLER RELAY – INRANGE RELAY (K-15) |
| DVR DUAL VOLTAGE RECEPTACLE (OPTION) (F-3) | TF CONTROLLER RELAY – DEFROST (K-8) |
| EF EVAPORATOR FAN CONTACTOR | TL CONTROLLER RELAY – COOL LIGHT (K-13) |
| HIGH SPEED (M-12, N-12, L-13) | TN CONTROLLER RELAY – CONDENSER FAN (K-11) |
| EM EVAPORATOR FAN MOTOR (E-12, F-12, G-12, T-12, | TP TEST POINT (G-11, J-12, H-14, J-10, M-17, H-11) |
| T-15) | TR TRANSFORMER (M-3) |
| ES EVAPORATOR FAN CONTACTOR | TRANS TRANSFORMER AUTO 230/460 (OPTION) (D-3) |
| LOW SPEED (M-13, N-12) | TRC TRANSFRESH REAR CONNECTOR (OPTION) (F-7) |
| F FUSE (D-7, E-21, F-21, H-6) | TV CONTROLLER RELAY – LOW SPEED EVAPORATOR |
| FLA FULL LOAD AMPS | FANS (K-13) |
| HPS HIGH PRESSURE SWITCH (H-10) | VPS VENT POSITION SENSOR (UPPER) (OPTION) (N-18) |
| HR HEATER CONTACTOR (L-14, P-3) | WP WATER PRESSURE SWITCH (OPTION) (E-11) |
| HS HUMIDITY SENSOR (G-23) | WCR WETTING CURRENT RESISTOR (OPTION) (J-11) |
| HTT HEAT TERMINATION THERMOSTAT (G-14) | |

Figure 8.2 Schematic Diagram

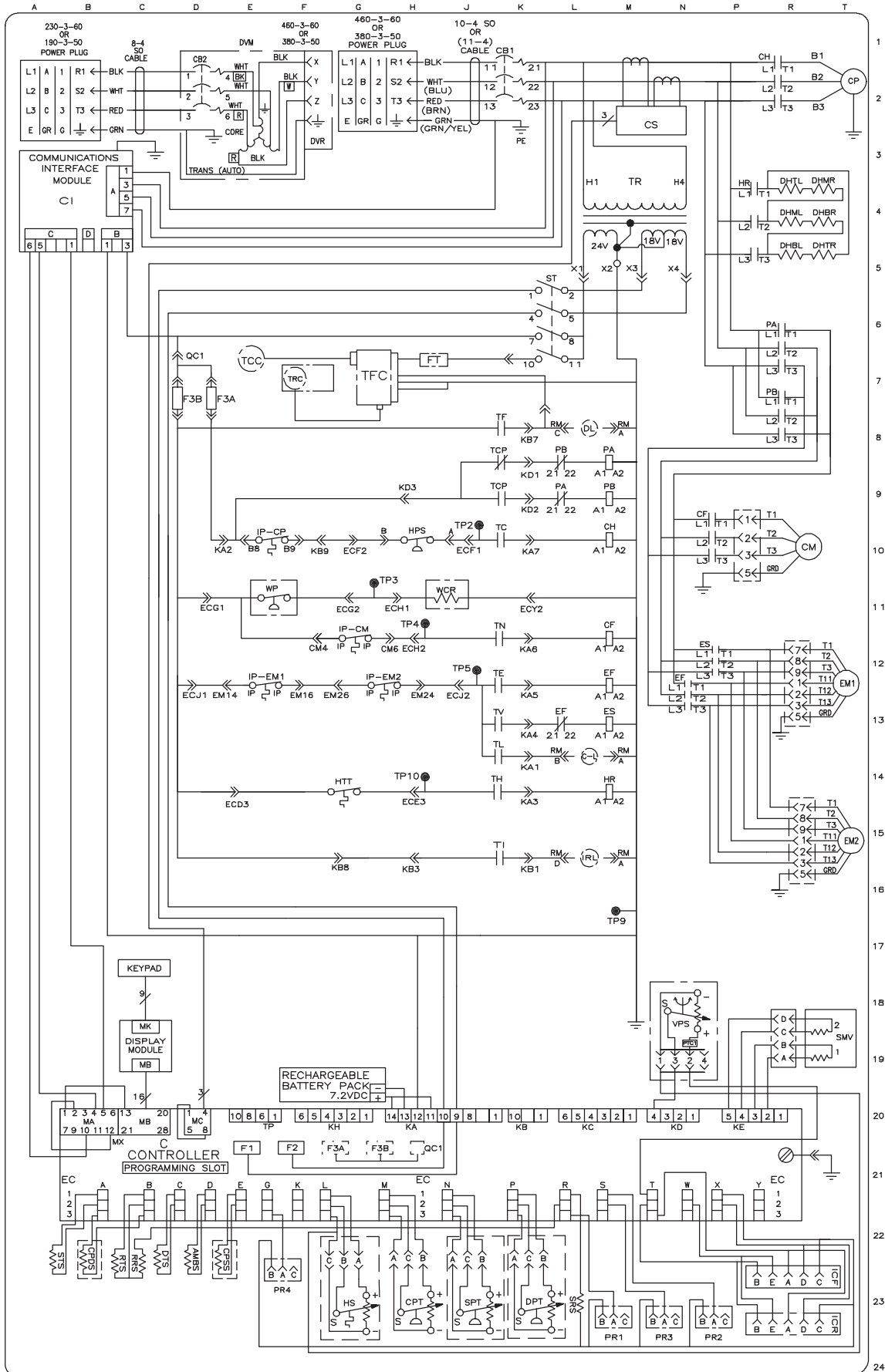

Based on Drawing 62-11730

Figure 8.3 Unit Wiring Diagram (Sheet 1 of 2)

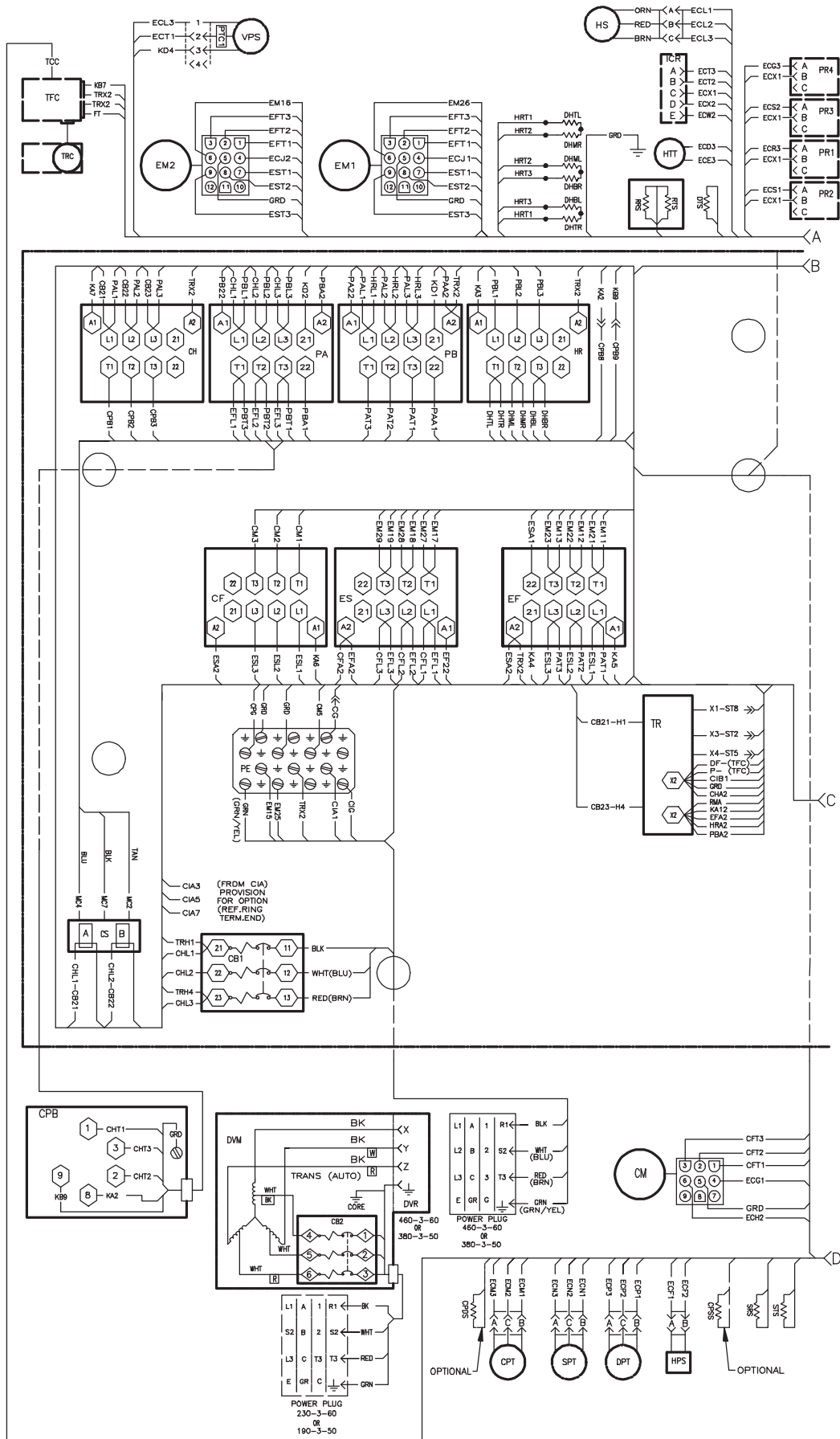

Based on Drawing 62-11730



China RoHS per SJ/T 11364-2014

产品中有害物质的名称及含量

| 部件名称 | 有害物质 | | | | | |
|--|-----------|-----------|-----------|------------------|---------------|-----------------|
| | 铅 (Pb) | 汞 (Hg) | 镉 (Cd) | 六价铬 (Cr (VI)) | 多溴联苯 (PBB) | 多溴二苯醚 (PBDE) |
| 金属板部件 | O | O | O | O | O | O |
| 塑料部件 | O | O | O | O | O | O |
| 盘管组件 | X | O | O | O | O | O |
| 加热部件 | O | O | O | O | O | O |
| 马达, 压缩机与风扇组件 | X | O | O | O | O | O |
| 温度控制微处理器系统 | X | O | O | O | O | O |
| 断路器与接触器 | O | O | O | O | O | O |
| 变压器 | O | O | O | O | O | O |
| 传感器 | X | O | O | O | O | O |
| 通讯组件 | O | O | O | O | O | O |
| 阀组件 | X | O | O | O | O | O |
| 电缆线/电源 | O | O | O | O | O | O |
| 电池 | O | O | X | O | O | O |
| 标签与绝缘材料 | O | O | O | O | O | O |
| 玻璃部件 | X | O | O | O | O | O |
| 本表格依据 SJ/T 11364 的规定编制。 O: 表示该有害物质在该部件所有均质材料中的含量均在 GB/T 26572 规定的限量要求以下。 X: 表示该有害物质至少在该部件的某一均质材料中的含量超出 GB/T 26572 规定的限量要求。 | | | | | | |

62-66122-01, Rev A

INDEX

Numerics

230 Volt Cable 2-2
460 Volt Cable 2-2

A

Adding Refrigerant to System 7-5
Adding Refrigerant to System - Partial 7-5
Adjust Fresh Air Makeup Vent 5-1
Air-Cooled Condenser Section 3-4
Alarm Configuration (dCF07 - dCF10) 4-16
Assemble the Evaporator Fan Assembly 7-15
Automatic Defrost 4-9
Autotransformer 2-2, 7-20

B

Back Panels 2-2
Battery 2-1
Battery Replacement 7-23

C

Cable Restraint 2-2
Check Controller Function Codes 5-4
Checking eAutoFresh Drive System 7-26
Checking High Pressure Switch 7-10
Checking Superheat 7-16
Checking the Controller 7-20
Checking the Refrigerant Charge 7-5
Checking the Stepper Valve 7-19
Communications Interface Module 2-2, 3-5
Communications Interface Module Installation 7-29
Complete Inspection 5-4
Compressor 2-1, 7-5
Compressor Disassembly 7-6
Compressor Oil Level 7-9
Compressor Reassembly 7-8
Compressor Section 3-3
Condenser Coil 2-1, 7-11
Condenser Coil Cleaning 7-11
Condenser Coil Installation 7-12
Condenser Coil Preparation 7-12
Condenser Coil Removal 7-11
Condenser Fan and Fan Motor 7-13
Condenser Fan Motor Remove/Replace 7-13
Condenser Grille 2-1
Condenser Pressure Control 4-11
Configuration Identification 2-1
Configuration Software (CnF Variables) 4-3

Connect Power 5-1
Connect Remote Monitoring Receptacle 5-4
Connection to 190/230VAC Power 5-1
Connection To 380/460 VAC Power 5-1
Control Box 2-1
Control Box Section 3-5
Controlled Atmosphere 2-2
Controller 2-1, 4-3, 7-20
Controller Alarms 4-12
Controller Configuration Variables 4-19
Controller Function Codes 4-21
Controller Pre-Trip Test Codes 4-42
Controller Programming Procedure 7-21
Controller Software 4-3
Controller Troubleshooting 7-21

D

DataCORDER 4-13
DataCORDER Alarms 4-18
DataCORDER Communications 4-16
DataCORDER Power-Up 4-16
DataCORDER Software 4-13
Defrost 4-9
Defrost Initiation 4-11
Defrost Related Settings 4-11
Dehumidification 2-1
Disassemble the Evaporator Fan Assembly 7-15
Display Module 2-2, 4-2

E

eAutoFresh 2-2
eAutoFresh Modes of Operation 5-3
eAutoFresh Operation 5-2
eAutoFresh Pre-Trip Inspection 5-3
eAutoFresh Service 7-26
eAutoFresh Start-Up Procedure 5-3
Electrical Data 3-7
Emergency Bypass 2-2
Emergency Bypass Operation (option) 5-7
Evacuation and Dehydration 7-3
 Complete System 7-4
 General 7-3
 Partial System 7-4
 Preparation 7-3
Evaporator 2-1
Evaporator Coil & Heater Assembly 7-13
Evaporator Coil Replacement 7-14
Evaporator Fan and Motor Assembly 7-15
Evaporator Fan Operation 2-1, 4-11

Evaporator Heater Replacement 7–14
Evaporator Section 3–2
Evaporator Section Cleaning 7–15

F

Failure Action 4–11
Feature Descriptions 2–1
Filter-Drier 7–13
First Aid 1–1
Fresh Air Makeup Vent 3–1
Frozen “Heat” Mode 4–8
Frozen Economy Mode 4–8
Frozen Idle Mode 4–8
Frozen Mode - Temperature Control 4–7
Frozen Mode Cooling – Sequence of Operation 4–9
Frozen Steady State 4–7

G

General Description 3–1
General Safety Notices 1–1
Generator Protection 4–11
Gutters 2–2

H

Handles 2–2
Handling Controller 7–20
High Pressure Switch 7–10

I

Inspection (Before Loading) 5–1
Interrogator 2–2
Introduction 2–1
ISO Trip Header 4–18

K

Keypad 4–2

L

Labels 2–2
Logging Interval (dCF03) 4–14
Lower Air (Fresh Air Make Up) 2–2

M

Maintenance of Painted Surfaces 7–29
Maintenance Precautions 1–1
Manifold Gauge Set 7–1
Modes of Operation 4–4

O

Operating Precautions 1–1
Operational Software (Cd Function Codes) 4–4
Option Descriptions 2–1

P

Perishable Economy 4–6
Perishable Heating 4–4
Perishable Idle, Air Circulation 4–4
Perishable Mode Cooling – Sequence of Operation 4–6
Perishable Mode Dehumidification 4–5
Perishable Mode Heating – Sequence of Operation 4–7
Perishable Mode Temperature Control 4–4
Perishable Pulldown 4–4
Perishable Steady State 4–4
Perishable, Dehumidification – Bulb Mode 4–6
Physical Inspection 5–4
Plate Set 2–1
Pressure Readout 2–1
Pre-trip Data Recording 4–16
Pre-Trip Diagnostics 4–12, 5–5
Probe Diagnostics 5–6
Protection Modes of Operation 4–11
Pump the Unit Down 7–3

Q

Quest – CCPC 2–2, 4–11

R

Refrigerant Charge 7–4
Refrigerant Leak Checking 7–3
Refrigeration Circuit 3–9
Refrigeration System Data 3–6
Refrigeration Unit – Front Section 3–1
Remote Monitoring 2–2
Removal and Replacement of Compressor 7–5
Removing and Installing the Controller 7–22
Replacing High Pressure Switch 7–11
Replacing the Evaporator Fan Assembly 7–15

S

Safety and Protective Devices 3–8
Sampling Type (dCF05 & dCF06) 4–16
Section Layout 7–1
Sensor Checkout Procedure 7–23
Sensor Configuration (dCF02) 4–14
Sensor Re-Installation 7–25
Sensor Replacement 7–24
Service Valves 7–2

Servicing the eAutoFresh Air Filter 7–26
Servicing the eAutoFresh Drive System 7–27
SMV Emergency Repair Procedure 7–20
Specific Hazard Statements 1–1
Start Temperature Recorder 5–4
Starting and Stopping Instructions 5–4
Starting the Unit 5–4
Start-Up Inspection 5–4
Stopping the Unit 5–4
Suction Modulation Valve 7–18

T

Temperature Control Microprocessor System 4–1
Temperature Readout 2–1
Temperature Sensor Service 7–23
Thermistor Format (dCF04) 4–14
Thermometer Port 2–2
Thermostatic Expansion Valve 7–16
TXV Replacement 7–17

U

Unit Introduction 2–1
Upper Air (Fresh Air Make Up) 2–2
Upper Fresh Air Makeup Vent 5–2
USDA 2–1
USDA Cold Treatment 4–17
USDA Cold Treatment Procedure 4–17

V

Valve Override Controls 7–19
Vent Position Sensor 5–2
Vent Position Sensor (VPS) 7–25



A member of the United Technologies Corporation. Stock symbol UTX.



**United
Technologies**

Building & Industrial Systems

Carrier Transicold Division,
Carrier Corporation
P.O. Box 4805
Syracuse, NY 13221 USA

www.carrier.transicold.com